

Jennifer Brooks Hutchinson  
Senior Counsel  
PPL Services Corporation  
[JHutchinson@pplweb.com](mailto:JHutchinson@pplweb.com)

280 Melrose Street  
Providence, RI 02907  
Phone 401-316-7429



February 12, 2026

**VIA ELECTRONIC MAIL AND HAND DELIVERY**

Stephanie De La Rosa, Commission Clerk  
Rhode Island Public Utilities Commission  
89 Jefferson Boulevard  
Warwick, RI 02888

**RE: Docket No. 25-54-EL – The Narragansett Electric Company d/b/a Rhode Island Energy  
Proposed FY 2027 Electric Infrastructure, Safety, and Reliability Plan  
Responses to PUC Data Requests – Set 1**

Dear Ms. De La Rosa:

On behalf of The Narragansett Electric Company d/b/a Rhode Island Energy (the “Company”), I am enclosing the Company’s responses to the Public Utilities Commission’s First Set of Data Requests in the above-referenced matter.

Thank you for your attention to this transmittal. If you have any questions or concerns, please do not hesitate to contact me at 401-316-7429.

Sincerely,

A handwritten signature in blue ink, appearing to read "Jennifer Brooks Hutchinson", with a long horizontal flourish extending to the right.

Jennifer Brooks Hutchinson

Enclosures

cc: Docket No. 25-54-EL Service List

PUC 1-1  
**Historical Spend/Plant In Service**

Request:

Please complete the attached Excel spreadsheet titled "25-54-EL Attach to PUC 1-1". For both tables, please use the ISR Fiscal Year April 1 through March 31. For purposes of this question, the Company should not limit non-ISR capital to investments that the Company believes could qualify under the ISR standard set forth in the Decoupling Act.

Response:

Please see Attachment PUC 1-1. Non-ISR Capital investments include Facilities, Information Technology, Electric Distribution system safety and reliability, and other capital investments.

**Assumptions for Revenue Requirement Calculations**

**ISR Additions**

For simplicity, the Company has used the FY 2027 ISR revenue requirement model to estimate an order of magnitude for FY 2027 and future ISR investments, which would use the same assumptions such as rate of return, tax rates and depreciation rates; however, when actually placed in service in either an ISR filing or base distribution rates, the Company would apply the current rates in effect at the time. Additionally, for simplicity, the revenue requirement amounts in this response do not reflect adjustments for Property Tax recovery or Hold Harmless adjustments.

Line 8 represents the revenue requirement on that year's capital ISR additions placed in service (either actual or forecasted). Line 9 represents the total revenue requirement for that year's capital placed in service on Line 8 and O&M from Line 5. Line 10 is the cumulative revenue requirement for that year which is the current year's revenue requirement on Line 9 plus the revenue requirement for prior year's investments placed in service. Please note that the first year an investment is placed in service reflects the half year convention of depreciation and subsequent year are a full year of depreciation.

Note that for FY 2019 and FY 2020, a portion of the capital placed in service was already in base distribution rates and, therefore, the revenue requirement amounts reflected in this table are only the portion that was incremental to base distribution rates beginning in 2019.

PUC 1-1, page 2

**Non-ISR Additions**

For simplifying assumptions in this response, the Non-ISR additions do not include any cost of removal or retirements in the revenue requirement calculation for these investments. For facilities and Non-ISR investments, the Company has used the FY 2027 ISR model to develop an order of magnitude hypothetical revenue requirement for each of the years. The actual revenue requirement could differ when rolled into base distribution rates depending on depreciation rates and rate of return at the time. For all Information Technology investments, the Company has used a life of 5 years for simplicity purposes in this response; however, the specific approved depreciation rate will be applied when the assets are in base distribution rates for recovery. Until the beginning of the Company's Rate Year 1 (August 1, 2026) in its base distribution filing in Docket No. 25-45-GE, none of the plant additions on Line 12 are being recovered in rates. For simplicity in this response, the Company has assumed that investments placed in service through FY 2025 on Line 12 will be included in base distribution rates beginning during FY 2027 (August 2026) and has prorated the FY 2027 amounts on Lines 13 and 14 based on that assumption, as well as the forecasted Facilities and IT investments that have been included in the base distribution rate filing through FY 2028.

Attachment to PUC 1-1

**Historical Data Electric ISR Capital**

	A	B	C	D	E	F	G	H	I	J	K	L	M
ISR FY	FY 2019	FY 2020	FY 2021	FY 2022	FY 2023	FY 2024	FY 2025	FY 2026	Proposed FY 2027	Proposed FY 2028	Subtotal FY 2019-2023	Subtotal FY 2024-2028	Total FY 2019-2028
1 Approved Capital Budget	114,601,000	115,800,000	115,450,000	116,200,375	121,049,620	127,987,469	199,080,508	231,612,000	167,763,000	167,978,000	583,100,995	894,420,977	1,477,521,972
2 Approved O&M Budget	10,936,000	11,507,000	12,092,000	11,983,000	13,139,000	15,113,000	14,140,000	14,716,000	14,265,000	14,705,950	59,657,000	72,939,950	132,596,950
3 <b>Total Approved ISR Budget</b>	<b>125,537,000</b>	<b>127,307,000</b>	<b>127,542,000</b>	<b>128,183,375</b>	<b>134,188,620</b>	<b>143,100,469</b>	<b>213,220,508</b>	<b>246,328,000</b>	<b>182,028,000</b>	<b>182,683,950</b>	<b>642,757,995</b>	<b>967,360,927</b>	<b>1,610,118,922</b>
4 Actual Capital Spend	119,021,303	118,063,482	111,926,390	114,473,057	114,495,786	135,426,687	209,598,285	237,559,000	167,763,000	167,978,000	577,980,018	918,324,972	1,496,304,990
5 Actual O&M Spend	10,469,000	11,516,290	11,531,947	12,081,003	13,731,126	14,929,629	13,922,884	14,716,000	14,265,000	14,705,950	59,329,366	72,539,463	131,868,829
6 <b>Actual Total Spend</b>	<b>129,490,303</b>	<b>129,579,772</b>	<b>123,458,337</b>	<b>126,554,060</b>	<b>128,226,912</b>	<b>150,356,316</b>	<b>223,521,169</b>	<b>252,275,000</b>	<b>182,028,000</b>	<b>182,683,950</b>	<b>637,309,384</b>	<b>990,864,435</b>	<b>1,628,173,819</b>
7 Plant Additions in Fiscal Year	110,051,680	100,261,534	115,360,166	86,464,029	91,148,774	97,249,250	112,519,466	208,824,000	182,666,000	151,014,000	503,286,183	752,272,716	1,255,558,899
8 Rev. Req. on Capital Additions	1,525,733	2,344,516	4,353,796	2,396,246	1,929,305	2,681,771	4,519,641	9,150,744	7,641,570	5,842,308	12,549,596	29,836,035	42,385,631
9 Incremental Rev. Req. (capital & O&M)	11,994,733	13,860,806	15,885,743	14,477,249	15,660,431	17,611,400	18,442,525	23,866,744	21,906,570	20,548,258	71,878,962	102,375,498	174,254,460
10 <b>Cumulative Revenue Requirement</b>	<b>11,994,733</b>	<b>18,206,826</b>	<b>25,652,243</b>	<b>32,446,763</b>	<b>38,407,192</b>	<b>44,933,854</b>	<b>50,879,025</b>	<b>63,523,998</b>	<b>77,719,898</b>	<b>89,030,946</b>	<b>126,707,757</b>	<b>326,087,721</b>	<b>452,795,478</b>

**Line Notes:**

Line 8 = revenue requirement on current year capital additions

Line 9 = Line 8 plus Line 5

Line 10 = Line 9 plus capital revenue requirement on capital investments placed in service in prior periods (beginning in 2019).

**Column Notes:**

Column H - Lines 8 through 10 include AMF revenue requirement without the offsetting deferral. In FY 2026, \$6,344,776 was forecasted to offset the Revenue Requirement

Column I - Lines 8 through 10 include AMF revenue requirement without the offsetting deferral. In FY 2027, \$7,856,360 was forecasted to offset the Revenue Requirement

**Historical Data Electric Non-ISR Capital**

	A	B	C	D	E	F	G	H	I	J	K	L	M
ISR FY	FY 2019	FY 2020	FY 2021	FY 2022	FY 2023	FY 2024	FY 2025	Current Forecast FY 2026	Proposed FY 2027	Proposed FY 2028	Total FY 2019-2023	Total FY 2024-2028	Total FY 2019-2028
11 Non-ISR Capital Spend	4,230,916	4,189,538	7,029,408	7,284,607	12,649,406	17,163,525	42,556,233	77,188,505	97,437,637	99,216,371	35,383,875	333,562,271	368,946,146
12 Non-ISR Capital Additions	2,714,944	2,325,034	1,750,019	8,883,366	585,574	9,622,579	12,724,096	46,066,101	57,722,792	124,599,735	16,258,938	250,735,302	266,994,240
13 Revenue Requirement Included in Rates for Non-ISR Plant Additions	0	0	0	0	0	0	0	0	8,473,146	21,333,531	0	29,806,677	29,806,677
14 Revenue Requirement NOT Included in Rates for Non-ISR Plant Additions (i.e. absorbed by NEC due to regulatory lag)	86,668	411,386	629,810	1,183,502	1,697,745	2,229,653	3,354,263	6,980,471	5,106,144	4,263,340	4,009,111	21,933,872	25,942,983

**Line Notes:**

Line 13 represents amounts currently in rates or proposed in the base distribution rate case filing to be effective August 2026

Line 14 represents amounts are not currently in rates or proposed in the base distribution rate case filing and will incur a regulatory lag until the next base distribution rate case

**Column Notes:**

Column I - for purposes of this response, for investments that are included in the base distribution rate case filing, the Company prorated the FY 2027 revenue requirement based on the Rate Year beginning August 2026.

Assumption - FY 2027 & FY 2028 - this line includes amounts the Company has proposed for recovery in the rate case

Assumption - FY 2027 & FY 2028 - this line reflects amounts that have not been proposed for recovery in the rate case

PUC 1-2  
**Historical Spend/Plant In Service**

Request:

Attachment 1A on Bates 111 identifies \$50,360,000 of Plant in Service for System Capacity and Performance projects in FY 2027. Please explain why this amount is much larger than any previous year dating back to at least FY 2012. Please provide a list of the projects included in that total as well as the Plant in Service amount related to each project.

Response:

System Capacity and Performance Plant in Service on Attachment 1B, line 6 on Bates 111, includes projects forecasted to go into service in FY 2027 for both the Consolidated Soft Budget Limit and Separately Tracked Major Projects categories. This amount is larger than previous years because the forecast includes plant additions of \$14.8 million associated with the Nasonville Substation project and \$9.1 million associated with the New Lafayette Substation project. A major substation project designated as System Capacity and Performance has not gone into service since FY 2021 when the Jepson Substation was completed.

Please see the table below for a list of System Capacity and Performance projects forecasted to go into service in FY 2027 and the related amounts.

The Narragansett Electric Company  
d/b/a Rhode Island Energy  
RIPUC Docket No. 25-54-EL

In Re: Proposed FY 2027 Electric Infrastructure, Safety and Reliability Plan  
Responses to the Commission’s First Set of Data Requests  
Issued on January 27, 2026

PUC 1-2, page 2

	(a)	(b)	(c)
<b>Line Number</b>	<b>Project Number</b>	<b>Project Grouping</b>	<b>FY 2027 Forecasted Plant Additions (\$000)</b>
1	C081683	New Lafayette 115/12kV D Line	\$3,500
2	C065187	Warren Substation Expansion D Line	5,600
3	C079494	Peacedale Substation 3V0	700
4	C087363	Wampanoag Substation 3V0	400
5	COS0015	Reliability Blanket	2,600
6	COS0016	Load Relief Blanket	960
7	COS0025	Substation Load Relief/Reliability Blanket	280
8	CRI3015	EMS - W. Greenville	800
9	CRI3041	Coventry 54F1 Reconductoring	4,700
10	CRI3028	Nasonville Substation D Line	600
11	CRI3094	Nasonville Expansion Woonsocket D Line	850
12	CRI3084	Wakefield 17F3 Feeder Relief	800
13	CRI3077	Lafayette 30F2 Feeder Upgrade	1,000
14	CRI3043	Kenyon 68F5 Extension	500
15	CRI3098	Electromechanical Relay Replacement Program	1,670
16	C005505	Transformer Upgrades	1,500
17	CRI3027	Nasonville Substation	14,800
18	C081675	New Lafayette Substation	9,100
19	<b>FY 2027 System Capacity &amp; Performance Plant in Service Target</b>		<b>\$50,360</b>

PUC 1-3  
**Historical Spend/Plant In Service**

Request:

Mr. Capwell's Attachment PDC-1 from Docket **24-54-EL** (Book 1, Bates 84) projected that 318,920 meters would be installed by 1/1/2026 (see column j.). In the same docket on Bates 78, lines 7 & 8, Mr. Capwell states meter installation will continue through August 2026.

On page 10 of the 2025 Annual Advanced Metering Functionality Progress Report submitted on December 31, 2025, the company states in part "As of November 30, 2025, 165,929 AMF meters have been exchanged. The Project is on track to exchange over 200,000 AMF meters by the end of the year." Figure 1 on page 3 of the same report seems to indicate that meter installation is expected to conclude by August 2026.

- a. Please reformat PDC-1 in **Docket No. 25-54-EL** (Book 1, Bates page 59) to reflect the format of PDC-1 in Docket No. 24-54-EL (Book 1, Bates page 84).
- b. Please explain how the company will achieve full deployment given that as of the end of CY 2025, meter installations are behind schedule by 100,000 or more meters.
- c. Please provide a new schedule in the same format as PDC-1 in Docket No. 24-54-EL for the period April 1, 2025 through March 31, 2027, including actuals where available and forecast/estimates where actuals are not available.

Response:

- a. Please see Attachment PUC 1-3-1.
- b. Although the project generally has progressed according to plan, the Company acknowledges that meter deployment is running behind the original plan. As of December 31, 2025, 204,832 AMF meters had been exchanged (see PDC-2 Docket No. 25-54-EL, Row 12, Column i) compared to the original forecast of 280,350 (see PDC-1 Docket No. 24-54-EL Row 12 Column i) resulting in 75,518 meters behind forecast. The Company anticipates meter deployment will be complete by the end of August 2026 as communicated in the AMF Annual Report Docket No. 22-49 EL and in the pre-filed testimony submitted by Mr. Capwell for Docket No. 25-54 EL.

Below outlines a summary overview of anticipated meter deployment progress through meter deployment completion and final project acceptance:

- As of the end of January 2026, the Company has installed 245,108 AMF meters.

PUC 1-3, page 2

- The Company anticipates February 2026 to be a slower month due to the winter field conditions and anticipates 7,500 AMF meters exchanged per week, on average.
  - The Company anticipates exchange production to increase for the month of March 2026, averaging 9,500 AMF meters exchanged per week for the month.
  - From early April 2026 through the end of July 2026, the Company forecasts an average of 11,000 AMF meter exchanges per week.
  - August will be a subtle ramp down and clean-up month, averaging approximately 6,000 AMF exchanges per week.
  - The Company forecasts that meter deployment will complete prior to Labor Day 2026.
  - Final project acceptance and completion is still on schedule for October 2026.
- c. Please see Attachment PUC 1-3-2.

Reformat of Attachment PDC-1 from Docket No. 25-54-EL (Book 1, Bates page 59)

<b>Scenario 1 (Systems and Network spend in service on Day 1( 6-1-25))</b>													
<b>Plant In Service</b>	<b>4/1/2026</b>	<b>5/1/2026</b>	<b>6/1/2026</b>	<b>7/1/2026</b>	<b>8/1/2026</b>	<b>9/1/2026</b>	<b>10/1/2026</b>	<b>11/1/2026</b>	<b>12/1/2026</b>	<b>1/1/2027</b>	<b>2/1/2027</b>	<b>3/1/2027</b>	<b>Total FY 2027</b>
	(a)	(b)	(c)	(d)	(e)	(f)	(g)	(h)	(i)	(j)	(k)	(l)	(m)
1 Systems (minus L+G MDMS)	\$ 785,993	\$ 655,073	\$ 610,459	\$ 956,506	\$ 157,825	\$ 76,215	\$ 2,009,925	\$ 15,792	\$ -	\$ -	\$ -	\$ -	\$ 5,267,788
2 Systems – Program allocation	\$ 36,514	\$ 28,414	\$ 51,364	\$ 28,414	\$ 28,414	\$ 36,377	\$ -	\$ -	\$ -	\$ -	\$ -	\$ -	\$ 209,497
<b>3 Systems Total</b>	<b>\$ 822,507</b>	<b>\$ 683,487</b>	<b>\$ 661,823</b>	<b>\$ 984,920</b>	<b>\$ 186,239</b>	<b>\$ 112,592</b>	<b>\$ 2,009,925</b>	<b>\$ 15,792</b>	<b>\$ -</b>	<b>\$ -</b>	<b>\$ -</b>	<b>\$ -</b>	<b>\$ 5,477,285</b>
<b>4 MDMS L+G only</b>	<b>\$ -</b>	<b>\$ -</b>	<b>\$ -</b>	<b>\$ 197,378</b>	<b>\$ -</b>	<b>\$ -</b>	<b>\$ 789,524</b>	<b>\$ -</b>	<b>\$ -</b>	<b>\$ -</b>	<b>\$ -</b>	<b>\$ -</b>	<b>\$ 986,902</b>
5 Meter	\$ 9,913,418	\$ 8,661,871	\$ 10,366,139	\$ 6,552,583	\$ 1,321,971	\$ -	\$ -	\$ -	\$ -	\$ -	\$ -	\$ -	\$ 36,815,982
6 Meter – Program allocation	\$ 85,200	\$ 66,300	\$ 119,850	\$ 66,300	\$ 66,300	\$ 84,879	\$ -	\$ -	\$ -	\$ -	\$ -	\$ -	\$ 488,827
<b>7 Meter Total</b>	<b>\$ 9,998,617</b>	<b>\$ 8,728,171</b>	<b>\$ 10,485,988</b>	<b>\$ 6,618,883</b>	<b>\$ 1,388,270</b>	<b>\$ 84,879</b>	<b>\$ -</b>	<b>\$ -</b>	<b>\$ -</b>	<b>\$ -</b>	<b>\$ -</b>	<b>\$ -</b>	<b>\$ 37,304,809</b>
8 Network	\$ 19,774	\$ 319,774	\$ 369,774	\$ 381,749	\$ 300,000	\$ -	\$ 1,034,823	\$ -	\$ -	\$ -	\$ -	\$ -	\$ 2,425,893
9 Network – Program Allocation	\$ 13,524	\$ 10,524	\$ 19,024	\$ 10,524	\$ 10,524	\$ 13,473	\$ -	\$ -	\$ -	\$ -	\$ -	\$ -	\$ 77,592
<b>10 Network Total</b>	<b>\$ 33,297</b>	<b>\$ 330,297</b>	<b>\$ 388,797</b>	<b>\$ 392,273</b>	<b>\$ 310,524</b>	<b>\$ 13,473</b>	<b>\$ 1,034,823</b>	<b>\$ -</b>	<b>\$ -</b>	<b>\$ -</b>	<b>\$ -</b>	<b>\$ -</b>	<b>\$ 2,503,485</b>
<b>11 Total</b>	<b>\$ 10,854,422</b>	<b>\$ 9,741,955</b>	<b>\$ 11,536,609</b>	<b>\$ 8,193,453</b>	<b>\$ 1,885,033</b>	<b>\$ 210,944</b>	<b>\$ 3,834,273</b>	<b>\$ 15,792</b>	<b>\$ -</b>	<b>\$ -</b>	<b>\$ -</b>	<b>\$ -</b>	<b>\$ 46,272,481</b>
<b>12 Meters Installed Forecast</b>	410,245	450,855	492,934	517,856	524,677	-	-	-	-	-	-	-	524,677
<b>13 % Total Meters Installed Forecast</b>	78%	86%	94%	99%	100%	100%	100%	100%	100%	100%	100%	100%	100%

Line 3= Line 1 + Line 2  
Line 7=Line 5 +Line 6  
Line 10=Line 8 + Line 9  
Line 11=Line 3+Line 4+Line 7 +Line 10  
Column m=sum of columns (a)-(i)

AMF Systems considered used and useful by 6/1/2025, All systems/Network spend placed in service on Day 1  
Meters are considered in service when installed, not when received into inventory  
Spend is placed into service based on G1's meter deployment schedule  
No Plant In Service for FY25, despite first meters being installed in March

**Plant In-Service (Capital Additions) - Actuals and Forecast - April 1, 2025 through March 31, 2026**

Scenario 1( Systems and Network spend in service on Day 1( 6-1-25)) Plant In Service	Actuals	Actuals	Actuals	Actuals	Actuals	Actuals	Actuals	Actuals	Actuals	Actuals	Forecast	Forecast	Forecast	Actuals + Forecast
	<u>4/30/2025</u>	<u>5/31/2025</u>	<u>6/30/2025</u>	<u>7/31/2025</u>	<u>8/31/2025</u>	<u>9/30/2025</u>	<u>10/31/2025</u>	<u>11/30/2025</u>	<u>12/31/2025</u>	<u>1/31/2026</u>	<u>2/28/2026</u>	<u>3/31/2026</u>	<u>Total FY 2026</u>	
	(a)	(b)	(c)	(d)	(e)	(f)	(g)	(h)	(i)	(j)	(k)	(l)	(m)	
1 Systems (minus L+G MDMS)	\$ -	\$ -	\$ -	\$ 12,690,370	\$ 355,806	\$ 370,152	\$ 2,826,104	\$ 511,764	\$ 68,012	\$ 572,794	\$ 4,145,883	\$ 2,593,674	\$ 24,134,560	
2 Systems – Program allocation	\$ -	\$ -	\$ -	\$ 765,613	\$ 52,156	\$ 55,770	\$ 23,965	\$ -	\$ 192,673	\$ 45,964	\$ 45,964	\$ 129,664	\$ 1,311,769	
<b>3 Systems Total</b>	<b>\$ -</b>	<b>\$ -</b>	<b>\$ -</b>	<b>\$ 13,455,983</b>	<b>\$ 407,962</b>	<b>\$ 425,922</b>	<b>\$ 2,850,070</b>	<b>\$ 511,764</b>	<b>\$ 260,685</b>	<b>\$ 618,759</b>	<b>\$ 4,191,847</b>	<b>\$ 2,723,338</b>	<b>\$ 25,446,329</b>	
<b>4 MDMS L+G only</b>	<b>\$ -</b>	<b>\$ -</b>	<b>\$ -</b>	<b>\$ 541,610</b>	<b>\$ 474,256</b>	<b>\$ -</b>	<b>\$ -</b>	<b>\$ -</b>	<b>\$ -</b>	<b>\$ 635,849</b>	<b>\$ -</b>	<b>\$ -</b>	<b>\$ 1,651,715</b>	
5 Meter	\$ -	\$ -	\$ 909,545	\$ 58,031	\$ 2,459,577	\$ 8,246,193	\$ 2,345,840	\$ 4,571,047	\$ 8,569,896	\$ 7,151,869	\$ 5,783,867	\$ 8,793,346	\$ 48,889,210	
6 Meter – Program allocation	\$ -	\$ -	\$ -	\$ 1,786,431	\$ 121,697	\$ 130,131	\$ 55,919	\$ -	\$ 449,570	\$ 107,250	\$ 107,250	\$ 302,550	\$ 3,060,795	
<b>7 Meter Total</b>	<b>\$ -</b>	<b>\$ -</b>	<b>\$ 909,545</b>	<b>\$ 1,844,461</b>	<b>\$ 2,581,274</b>	<b>\$ 8,376,324</b>	<b>\$ 2,401,759</b>	<b>\$ 4,571,047</b>	<b>\$ 9,019,466</b>	<b>\$ 7,259,119</b>	<b>\$ 5,891,116</b>	<b>\$ 9,095,895</b>	<b>\$ 51,950,006</b>	
8 Network	\$ -	\$ -	\$ 5,774,609	\$ 146,754	\$ 857,975	\$ 505,409	\$ 20,904	\$ 16,070	\$ 1,476,743	\$ 40,136	\$ 582,266	\$ 4,099,413	\$ 13,520,279	
9 Network – Program Allocation	\$ -	\$ -	\$ 279,021	\$ 4,540	\$ 19,317	\$ 20,656	\$ 8,876	\$ -	\$ 71,360	\$ 17,024	\$ 17,024	\$ 48,024	\$ 485,841	
<b>10 Network Total</b>	<b>\$ -</b>	<b>\$ -</b>	<b>\$ 6,053,630</b>	<b>\$ 151,294</b>	<b>\$ 877,292</b>	<b>\$ 526,065</b>	<b>\$ 29,780</b>	<b>\$ 16,070</b>	<b>\$ 1,548,103</b>	<b>\$ 57,160</b>	<b>\$ 599,290</b>	<b>\$ 4,147,437</b>	<b>\$ 14,006,119</b>	
<b>11 Total</b>	<b>\$ -</b>	<b>\$ -</b>	<b>\$ 6,963,174</b>	<b>\$ 15,993,348</b>	<b>\$ 4,340,783</b>	<b>\$ 9,328,311</b>	<b>\$ 5,281,608</b>	<b>\$ 5,098,881</b>	<b>\$ 10,828,253</b>	<b>\$ 8,570,886</b>	<b>\$ 10,682,253</b>	<b>\$ 15,966,670</b>	<b>\$ 93,054,169</b>	
<b>12 Meters Installed Forecast</b>	361	1,001	13,521	39,045	60,281	93,321	126,384	165,613	204,832	245,108	275,108	316,908	316,908	
<b>13 % Total Meters Installed Forecast</b>	0%	0%	3%	13%	22%	30%	38%	46%	38%	47%	52%	60%	60%	
Line 3= Line 1 + Line 2														
Line 7=Line 5 +Line 6														
Line 10=Line 8 + Line 9														
Line 11=Line 3+Line 4+Line 7 +Line 10														
Column m=sum of columns (a)-(l)														

AMF Systems considered used and useful by 6/1/2025, All systems/Network spend placed in service on Day 1  
Meters are considered in service when installed, not when received into inventory  
Spend is placed into service based on G1's meter deployment schedule  
No Plant In Service for FY25, despite first meters being installed in March

Plant In-Service (Capital Additions) - Forecast - April 1, 2026 through March 31, 2027 (and FY 2026 + FY 2027 Total)

Scenario 1( Systems and Network spend in service on Day 1( 6-1-25))	Forecast	Forecast	Forecast	Forecast	Forecast	Forecast	Forecast	Forecast	Forecast	Forecast	Forecast	Forecast	Forecast	Total Forecasted Plant In-Service FY 2026 + FY 2027
	4/30/2026	5/31/2026	6/30/2026	7/31/2026	8/31/2026	9/30/2026	10/31/2026	11/30/2026	12/31/2026	1/31/2027	2/28/2027	3/31/2027	Total FY 2027	
	(a)	(b)	(c)	(d)	(e)	(f)	(g)	(h)	(i)	(j)	(k)	(l)	(m)	(o)
Plant In-Service														
1 Systems (minus L+G MDMS)	\$ 785,993	\$ 655,073	\$ 610,459	\$ 956,506	\$ 157,825	\$ 76,215	\$ 73,387	\$ 73,387	\$ 2,032,777	\$ -	\$ -	\$ -	\$ 5,421,620	\$ 29,556,180
2 Systems – Program allocation	\$ 59,295	\$ 51,195	\$ 74,145	\$ 51,195	\$ 51,195	\$ 36,377	\$ -	\$ -	\$ -	\$ -	\$ -	\$ -	\$ 323,399	\$ 1,635,169
<b>3 Systems Total</b>	<b>\$ 845,288</b>	<b>\$ 706,267</b>	<b>\$ 684,604</b>	<b>\$ 1,007,700</b>	<b>\$ 209,019</b>	<b>\$ 112,592</b>	<b>\$ 73,387</b>	<b>\$ 73,387</b>	<b>\$ 2,032,777</b>	<b>\$ -</b>	<b>\$ -</b>	<b>\$ -</b>	<b>\$ 5,745,020</b>	<b>\$ 31,191,349</b>
<b>4 MDMS L+G only</b>	<b>\$ -</b>	<b>\$ 444,043</b>	<b>\$ -</b>	<b>\$ -</b>	<b>\$ -</b>	<b>\$ 197,378</b>	<b>\$ -</b>	<b>\$ -</b>	<b>\$ 789,524</b>	<b>\$ -</b>	<b>\$ -</b>	<b>\$ -</b>	<b>\$ 1,430,945</b>	<b>\$ 3,082,660</b>
5 Meter	\$ 9,849,433	\$ 9,431,775	\$ 9,129,660	\$ 9,069,346	\$ 8,247,439	\$ 1,779,678	\$ 1,944,754	\$ -	\$ -	\$ -	\$ -	\$ -	\$ 49,452,085	\$ 98,341,295
6 Meter – Program allocation	\$ 138,354	\$ 119,454	\$ 173,004	\$ 119,454	\$ 119,454	\$ 84,879	\$ -	\$ -	\$ -	\$ -	\$ -	\$ -	\$ 754,599	\$ 3,815,394
<b>7 Meter Total</b>	<b>\$ 9,987,787</b>	<b>\$ 9,551,229</b>	<b>\$ 9,302,664</b>	<b>\$ 9,188,800</b>	<b>\$ 8,366,893</b>	<b>\$ 1,864,557</b>	<b>\$ 1,944,754</b>	<b>\$ -</b>	<b>\$ -</b>	<b>\$ -</b>	<b>\$ -</b>	<b>\$ -</b>	<b>\$ 50,206,683</b>	<b>\$ 102,156,689</b>
8 Network	\$ 78,537	\$ 378,537	\$ 128,537	\$ 90,513	\$ 300,000	\$ 350,000	\$ 300,000	\$ -	\$ 1,034,823	\$ -	\$ -	\$ -	\$ 2,660,947	\$ 16,181,226
9 Network – Program Allocation	\$ 21,961	\$ 18,961	\$ 27,461	\$ 18,961	\$ 18,961	\$ 13,473	\$ -	\$ -	\$ -	\$ -	\$ -	\$ -	\$ 119,778	\$ 605,618
<b>10 Network Total</b>	<b>\$ 100,498</b>	<b>\$ 397,498</b>	<b>\$ 155,998</b>	<b>\$ 109,474</b>	<b>\$ 318,961</b>	<b>\$ 363,473</b>	<b>\$ 300,000</b>	<b>\$ -</b>	<b>\$ 1,034,823</b>	<b>\$ -</b>	<b>\$ -</b>	<b>\$ -</b>	<b>\$ 2,780,725</b>	<b>\$ 16,786,844</b>
<b>11 Total</b>	<b>\$ 10,933,573</b>	<b>\$ 11,099,037</b>	<b>\$ 10,143,266</b>	<b>\$ 10,305,974</b>	<b>\$ 8,894,873</b>	<b>\$ 2,538,000</b>	<b>\$ 2,318,141</b>	<b>\$ 73,387</b>	<b>\$ 3,857,124</b>	<b>\$ -</b>	<b>\$ -</b>	<b>\$ -</b>	<b>\$ 60,163,373</b>	<b>\$ 153,217,542</b>
<b>12 Meters Installed Forecast</b>	362,850	408,793	454,735	500,677	524,677									
<b>13 % Total Meters Installed Forecast</b>	69%	78%	87%	95%	100%									
Line 3= Line 1 + Line 2														
Line 7=Line 5 +Line 6														
Line 10=Line 8 + Line 9														
Line 11=Line 3+Line 4+Line 7 +Line 10														
Column (m)=sum of columns (a)-(l)														
Column (o)=column (m) FY26 + column(m) FY27														

PUC 1-4  
**AMF**

Request:

Please Update the Confidential Excel Spreadsheet Attachment H from **Docket No. 22-49-EL** for Deployment Years 1-4, with a column for actuals by year, where known. (Example: between columns R and S should be the actuals for Year 1; and between the current columns S and T should be the actuals for Year 2, etc.) In the update column, please put the actual calendar year that corresponds with each Deployment Year.

Response:

The Company originally interpreted this question as asking for the actual costs for Deployment Years 1-4 as previously shown in the Confidential Excel Spreadsheet Attachment H from Docket No. 22-49-EL. In response, the Company is providing the Excel Spreadsheet Attachment PUC 1-4-1, which aligns with the categories of costs outlined in the benefit-cost analysis (“BCA”) narrative of Attachment H submitted in Docket No. 22-49-EL, broken out by CapEx and OpEx because this is the cost structure the Company is using to track costs for the Advanced Metering Functionality (“AMF”) project. The Company remains on track to meet the approved CapEx Cap of \$153,217,548 for AMF deployment.

The Company has since clarified this question with the Public Utilities Commission (the “Commission”) counsel and understands this question relates to updating Sheet 10 of the revised Attachment H Excel file (i.e., the revised BCA file) that the Company filed on December 26, 2023 in compliance with the Commission’s September 27, 2023 Open Meeting motions and votes approving with conditions the Company’s AMF Business Case. Sheet 10 lists each individual project component for the categories of costs presented in Attachment PUC 1-4 (e.g., Meters, Network, Systems and Program). Because Sheet 10 was developed for purposes of budgeting and project scope development and not for cost control purposes, the Company will need to back feed the cost data presented in Attachment PUC 1-4 into Sheet 10, which the Company is in the process of completing.

The Company will supplement this response by providing the updated Sheet 10 of the Confidential Excel Spreadsheet Attachment H once complete.

Updated Attachment H From Docket No. 22-49-EL		DEPLOYMENT					
		(a)	(b)	(c)	(d)	(e)	
		2023	2024	2025	2026		
CapEx Costs		Year 1	Year 2	Year 3	Year 4	Total Deployment	
1	Meter Costs	Hardware	\$ -	\$ 12,852,827	\$ 55,503,711		\$ 68,356,538
2		Installs	\$ -	\$ 1,651,460	\$ 1,900,521		\$ 3,551,981
3		Pre-Sweeps	\$ -	\$ -	\$ 4,713,990		\$ 4,713,990
4		Project Management	\$ -	\$ 309,262	\$ 864,981		\$ 1,174,243
5	<b>Total Meter Costs</b>		\$ -	\$ 14,813,549	\$ 62,983,203		\$ 77,796,752
6							
7	Network Costs	Installs	\$ -	\$ 1,090,827	\$ 2,581,084		\$ 3,671,911
8		Hardware	\$ -	\$ 2,150,186	\$ 2,634,171		\$ 4,784,358
9		Project Management	\$ -	\$ 158,311	\$ 266,377		\$ 424,688
10	<b>Total Network Costs</b>		\$ -	\$ 3,399,324	\$ 5,481,632		\$ 8,880,957
11							
12	Systems Costs	Headend	\$ 703,145	\$ 1,489,616	\$ 2,878,356		\$ 5,071,117
13		L&G MDMS	\$ 319,589	\$ 222,021	\$ 474,256		\$ 1,015,866
14		Cust Engagement	\$ -	\$ 962,054	\$ 3,499,940		\$ 4,461,994
15		Analytics	\$ -	\$ 1,465	\$ 720		\$ 2,184
16		Middleware	\$ -	\$ 1,477	\$ 499,243		\$ 500,720
17		ADMS	\$ -	\$ 173,815	\$ 149,326		\$ 323,141
18		OMS	\$ -	\$ 523	\$ 254,193		\$ 254,715
19		Project Management	\$ 14,703	\$ 302,573	\$ 780,933		\$ 1,098,209
20		Cyber Security	\$ -	\$ 52,279	\$ 48,210		\$ 100,489
21		CSS	\$ 317,409	\$ 2,111,995	\$ 2,730,949		\$ 5,160,352
22		Depl Exchange Mgt	\$ -	\$ 19,489	\$ 383,910		\$ 403,399
23	<b>Total Systems Costs</b>		\$ 1,354,846	\$ 5,337,308	\$ 11,700,033		\$ 18,392,187
24							
25	Program Costs	Project Management	\$ -	\$ 1,466,947	\$ 2,888,429		\$ 4,355,376
26	<b>Total Program Costs</b>		\$ -	\$ 1,466,947	\$ 2,888,429		\$ 4,355,376
27							
28	<b>Total CapEx Costs</b>		\$ 1,354,846	\$ 25,017,128	\$ 83,053,297		\$ 109,425,271
29							
30	<b>OpEx Costs</b>						
31							
32	Meter Costs	Repairs	\$ -	\$ 67,805	\$ 210,913		\$ 278,718
33	<b>Total Meter Costs</b>		\$ -	\$ 67,805	\$ 210,913		\$ 278,718
34							
35	Network Costs	Steady State Operations	\$ -	\$ 5,797	\$ 72,216		\$ 78,013
36	<b>Total Network Costs</b>		\$ -	\$ 5,797	\$ 72,216		\$ 78,013
37							
38	Systems Costs	Headend	\$ -	\$ 127,743	\$ 751,241		\$ 878,984
39		MDMS	\$ -	\$ 200,311	\$ 553,709		\$ 754,020
40		Cust Engagement	\$ -	\$ -	\$ 85,729		\$ 85,729
41	<b>Total Systems Costs</b>		\$ -	\$ 328,054	\$ 1,390,680		\$ 1,718,734
42							
43	Program Costs	Change Management	\$ -	\$ 1,134,307	\$ 1,680,195		\$ 2,814,501
44	<b>Total Program Costs</b>		\$ -	\$ 1,134,307	\$ 1,680,195		\$ 2,814,501
45							
46	<b>Total OpEx Costs</b>		\$ -	\$ 1,535,963	\$ 3,354,004		\$ 4,889,966
47							
48	<b>Total AMF Costs</b>		\$ 1,354,846	\$ 26,553,091	\$ 86,407,300		\$ 114,315,237

PUC 1-5  
**Capital Spending – Non-ISR**

Request:

On Bates page 16, Mr. LaFond explains the company chose to advance certain projects outside of the ISR. Please provide:

- a. A brief explanation of each project.
- b. The reasons the company believes each project is necessary, including an explanation of what issue will be resolved by each project.
- c. The expected spending on each project in FY 2026 and FY 2027.

Response:

- a. The following projects are being executed outside the ISR. Included is a description of each project. Each of these projects has previously been proposed in an ISR docket for approval and a reference docket for each is given to provide additional information.

	(a)	(b)	(c)
1	Project	Description	Reference Docket
2	Phillipsdale Substation and Distribution Line projects	Rebuild substation and distribution line to address asset condition risks, provide load relief, to other area substations, and advance the retirement of the 23kV sub-transmission system.	23-48-EL Attachment 5
3	Providence Longterm Study Phase 5 - Auburn Substation and Distribution Line projects	Rebuild and convert the existing substation and retire other area substations due to asset condition risks and loading issues.	24-54-EL
4	Division Street Substation – replacement of T1 and T2	Replace two substation power transformers, and associated equipment, due to asset condition.	23-48-EL Attachment 5
5	Johnston Substation VVO/CVR project	Install capacitors and regulators to optimize the performance of the distribution system and deliver energy at peak efficiency.	24-54-EL
6	Staples #112 Reliability projects	Reconductor distribution line with spacer cable and install feeder tie to improve reliability.	24-54-EL Attachment 5
7	Spare Transformer Purchases	Procure spare substation power transformers to improve resiliency and reduce the risk of unserved load and/or contingency loading issues.	24-54-EL Attachment 5
8	Mobile Substation Purchases	Procure mobile substation components to improve resiliency and reduce the risk of unserved load and/or contingency loading issues.	24-54-EL

All dollars values are given in millions.

PUC 1-5, page 2

- b. The Company observes that nothing in the Revenue Decoupling Law prevents the Company from making investments that the Company determines are reasonably necessary and prudent investments for safe and reliable service and to recover the costs of those investments outside of the ISR Plan process (e.g., future base distribution rate case). The Commission acknowledged as much in its written order in Docket No. 24-54-EL,

[T]he Commission reminds the Company that nothing in the framework nor the decision to limit eligibility for ISR cost recovery relieves the Company from adequately investing in its system. It is the Company and not the Commission that ultimately bears responsibility to provide safe and reliable service. The ISR serves as an accelerated cost recovery tool for investments that the Company can prove meet the statutory standard. Nothing in this order prohibits the Company from making needed investments and seeking cost recovery in its next rate case.<sup>1</sup> (citations omitted)

The Company decides whether to proceed with investments outside of the ISR process by applying the same rigorous examination of system risk and need as those made within the ISR. With respect to the projects listed in part a., above, the Company has included its justification and needs analysis for these projects as part of prior ISR Plan filings, and those justifications and needs analyses have not changed. Indeed, the Company maintains that these projects should otherwise be eligible for recovery through the ISR, and the Division did not object to the need for these projects when it examined the Company’s FY 2026 ISR Plan. Notwithstanding, as explained in the Pre-Filed Direct Testimony of Company witness Philip LaFond in this docket, to maintain the FY 2027 ISR budgets relatively flat over FY 2026, and to continue to make the investments it has identified as necessary for the safety and reliability of the electric distribution system, the Company determined that the best course of action is to progress certain projects outside the ISR.<sup>2</sup>

The Company interprets R.I. Gen. Laws § 39-1-27.7.1 (“Revenue Decoupling Law”) to apply to investments which are included in the Company’s proposed ISR plan for the prospective fiscal year and are eligible for prospective cost recovery through the ISR mechanism. If there is not an agreement between the Company and the Division with respect to a proposed ISR plan and budget, the standard for approval of cost recovery as part of the ISR annual cost recovery mechanism is that the proposed investments must be “reasonably needed to maintain safe and reliable distribution service over the short and the

---

<sup>1</sup> Report and Order No. 25470, Docket No. 24-54-EL at 15-16 (July 17, 2025).

<sup>2</sup> Rhode Island Energy Proposed FY 2027 Electric Infrastructure, Safety, and Reliability Plan, Docket No. 25-54-EL, Pre-Filed Direct Testimony of Company Witness Philip LaFond at 17.

The Narragansett Electric Company  
d/b/a Rhode Island Energy  
RIPUC Docket No. 25-54-EL

In Re: Proposed FY 2027 Electric Infrastructure, Safety and Reliability Plan  
Responses to the Commission’s First Set of Data Requests  
Issued on January 27, 2026

PUC 1-5, page 3

long term.” In exchange, the Revenue Decoupling law provides the Division and the Commission with granular visibility and real-time review of the Company’s proposed investments. Unlike the prospective cost recovery mechanism in the ISR, investments made outside of the ISR process are not subject to the same review process and standard as ISR projects under the Revenue Decoupling law; thus, the Company, as the asset manager, may use its discretion to make the investments it determines are necessary to meet its obligations to maintain safety and reliability, provided the Company can demonstrate that such investment decisions were reasonable and prudent under the circumstances existing at the time it made the investment decision.

- c. Subject to the explanation in part b., above, the Company provides the actual and forecasted spending for the projects listed in part a., above in FY 2026 and FY 2027.

	(a)	(b)	(c)	(d)
1	Project	Pre-FY 2026 CAPEX	FY 2026 CAPEX Forecast	FY 2027 CAPEX Forecast
2	Phillipsdale Substation and Distribution Line projects	\$0.87	\$3.70	\$7.50
3	Providence Longterm Study Phase 5 - Auburn Substation and Distribution Line projects	\$0.00	\$0.20	\$5.60
4	Division Street Substation – replacement of T1 and T2	\$0.10	\$0.40	\$3.00
5	Johnston Substation VVO/CVR project	\$0.00	\$0.10	\$1.40
6	Staples #112 Reliability projects	\$0.20	\$1.60	\$2.30
7	Spare Transformer Purchases	\$0.00	\$7.80	\$14.90
8	Mobile Substation Purchases	\$0.00	\$3.20	\$5.70

All dollars values are given in millions.

PUC 1-6  
**Capital Spending – Non-ISR**

Request:

- a. Is the Company advancing the Distribution Automated Recloser Program, or a project akin to that project outside of the ISR?
- b. If so, please provide the anticipated roll-out schedule and associated spend.
- c. How much of the expense does the Company expect to recover from the IJJA and how much does the Company expect to recover from customers?

Response:

- a. No. The Company is not advancing a Distribution Automated Recloser Program, or any similar program, outside of the ISR at this time. The Company has installed reclosers on certain underperforming circuits outside the ISR Plan process as further described in the pre-filed direct testimony of Company witness Kathy Castro submitted in the Company’s base distribution rate case filing in Docket No. 25-45-GE, Book 1, Bates Pages 130-132. These reclosers were placed in service between October 2024 – April 2025 and the associated spend is included in the Company’s revenue requirement schedules to the pre-filed direct testimony of Company witness Stephanie A. Briggs in Docket No. 25-45-GE. Going forward, the Company intends to install reclosers on a project-by-project basis where necessary to address safety and reliability needs.
- b. The anticipated roll-out schedule, and associated spend, for the non-ISR recloser investments that are associated with larger projects is below.

	(a)	(b)	(c)
	Fiscal Year	Number of Reclosers	Estimated Cost (\$000)
1	FY 2026	4	\$326
2	FY 2027	8	\$656
3	FY 2028	0	\$0
4	FY 2029	34	\$2,968
5	FY 2030	22	\$1,920

PUC 1-6, page 2

- c. Although the Company is not advancing a Distribution Automated Recloser Program currently, advanced reclosers are among the types of investments eligible for reimbursement by the IJA award.

At this time, the Company cannot state how much of the expense will be covered by the IJA award and how much the Company expects to recover from customers, because the award status and potential modifications are still under review by the U.S. Department of Energy (“DOE”) and remain subject to change. The Company has discretion to apply potential IJA award reimbursement to any eligible investments. Please see the Company’s responses to Division Data Requests 4-1, 4-4, 4-13, 4-14 and 4-17 in this docket for additional details regarding the Company’s cost-share obligation, eligible investments, and award status.

PUC 1-7  
**Capital Spending – Non-ISR**

Request:

A review of the budget does not show spending on Fiber beyond the study in FY 2025. DIV-4-8 shows IJJA funding potential for fiber backbone. Please describe the status of the fiber investment plans.

Response:

The Company is not currently progressing with the installation of a fiber backbone. The Company is in the process of updating the proposed IJJA investment commitments. Please also see the Company's responses to Data Requests Division 4-6 and Division 4-12 in this docket.

PUC 1-8  
**IIJA**

Request:

Please identify the line item where any IIJA-related investments and associated spending appear in Attachment 3 in Section 2 of the capital spending plan (as such spending appears in the FY 2027 proposal and/or five-year forecast of the spending plan). If the investment is a subset of a line item, please state the subtotal that represents the applicable investment.

Response:

At this time, the Company cannot state how much of the expense will be covered by the IIJA award because the award status and potential modifications are still under review by the U.S. Department of Energy (“DOE”) and remain subject to change. The Company has discretion to apply potential IIJA award reimbursement to any eligible investments. Please see the Company’s responses to Division Data Requests 4-1, 4-4, 4-13, 4-14 and 4-17 in this docket for additional details regarding the Company’s cost-share obligation, eligible investments, and award status.

Table 1, below, summarizes the lines within Attachment 3 containing IIJA-related investments, which are subject to change by DOE. The total per project is an estimate based on the forecasted number of devices per project and the fiscal year (FY) in which the eligible device goes into service. The total amount may shift between ISR fiscal years as the IIJA award period (October 1 through September 30) is offset 6 months compared to the ISR FY calendar (April 1 – March 30). As costs are incurred on the IIJA eligible investments, they will be submitted for reimbursement consideration to the DOE. The Company presently is eligible to be reimbursed for 18% of the actual costs incurred, therefore, the Company would seek reimbursement for 18% of the estimated spend summarized in Table 1. Investments are subject to change as the Company is in continued discussions with DOE regarding the award status and potential modifications due to the change in investment levels and other DOE required modifications.

The Narragansett Electric Company  
d/b/a Rhode Island Energy  
RIPUC Docket No. 25-54-EL

In Re: Proposed FY 2027 Electric Infrastructure, Safety and Reliability Plan  
Responses to the Commission’s First Set of Data Requests  
Issued on January 27, 2026

PUC 1-8, page 2

**Table 1**

	(a)	(b)	(c)	(d)	(e)	(f)
	<b>Category</b>	<b>Page in Attachment 3</b>	<b>Line in Attachment 3</b>	<b>FY27 Estimated IJA Spend</b>	<b>FY28 Estimated IJA Spend</b>	<b>FY29 Estimated IJA Spend</b>
1	<b>Damage Failure</b>					
2	Failed Assets - Specific Projects	Page 1	15	\$ 753,498	\$ -	\$ -
3	<b>Total - Failed Assets - Specific Projects</b>			\$ 753,498	\$ -	\$ -
4	<b>Asset Condition</b>					
5	Providence Study Ph1 - Ph4	Page 2	2	\$ -	\$ 1,319,553	\$ -
6	Tiverton Substation	Page 2	3	\$ -	\$ 642,360	\$ -
7	Other Area Study Projects - BSVS	Page 2	8	\$ -	\$ 85,320	\$ 436,415
8	Other Area Study Projects - CRIE	Page 2	9	\$ -	\$ -	\$ 120,895
9	Other Area Study Projects - CRIW	Page 2	10	\$ -	\$ 727,680	\$ 241,790
10	Other Area Study Projects - Newport	Page 2	11	\$ -	\$ 455,952	\$ -
11	Other Area Study Projects - NWRI	Page 2	12	\$ -	\$ 321,674	\$ -
12	<b>Total - Asset Condition</b>			\$ -	\$ 3,552,539	\$ 799,100
13	<b>System Capacity &amp; Performance</b>					
14	East Providence Substation D Line	Page 3	2	\$ 1,000,824	\$ 1,681,516	\$ -
15	Warren Substation	Page 3	3	\$ 1,215,142	\$ -	\$ -
16	New Lafayette Substation	Page 3	4	\$ 583,814	\$ -	\$ -
17	Weaver Hill Road Substation	Page 3	5	\$ -	\$ -	\$ 1,269,672
18	Blanket Projects	Page 3	7	\$ 1,983,006	\$ 1,195,021	\$ 1,188,891
19	Electromechanical Relay Upgrades	Page 3	9	\$ 2,285,000	\$ 10,824,000	\$ 6,594,000
20	EMS/RTU Program	Page 3	11	\$ 125,583	\$ 788,562	\$ -
21	Other Area Study Projects - East Bay	Page 3	14	\$ 231,040	\$ 250,206	\$ -
22	Other Area Study Projects - SCE	Page 3	17	\$ 118,177	\$ 164,285	\$ -
23	<b>Total - System Capacity &amp; Performance</b>			\$ 7,542,586	\$ 14,903,590	\$ 9,052,563
24	<b>Major Project - A/C</b>					
25	Apponaug Substation	Page 4	4	\$ -	\$ -	\$ 262,854
26	Hospital Sub Equipment Replacement	Page 4	7	\$ -	\$ -	\$ 1,725,804
27	<b>Total - Major Project - A/C</b>			\$ -	\$ -	\$ 1,988,658
28	<b>Total</b>			\$ 8,296,084	\$ 18,456,129	\$ 11,840,321

The Narragansett Electric Company  
d/b/a Rhode Island Energy  
RIPUC Docket No. 25-54-EL

In Re: Proposed FY 2027 Electric Infrastructure, Safety and Reliability Plan  
Responses to the Commission’s First Set of Data Requests  
Issued on January 27, 2026

---

PUC 1-9  
**IIJA**

Request:

A discussion of the Infrastructure and Investment and Jobs Act begins on Bates 108. The company explains that certain ISR work is eligible for IIJA reimbursement.

- a. Does the company anticipate receiving any reimbursements in FY 2026 or FY 2027?
- b. If yes, please identify the projects and the anticipated reimbursements.
- c. If yes, please explain how the reimbursements will be treated for ratemaking purposes.

Response:

- a. The Company is in the process of seeking potential reimbursement for investments made during the first budget period. The Company expects to seek reimbursement for FY 2025, FY 2026, and FY 2027, if authorized by the federal government.
- b. Table 1, below, summarizes actual costs from the start of the award (October 2024) through the latest reporting quarter (December 2025), which the Company is preparing to submit to the Department of Energy (DOE). The potential reimbursement amount in column ‘b’ represents 18% of the actual costs incurred plus the forecasted spend through FY 2027. Reimbursement for the figures listed below are subject to review and approval by DOE. The Company is in the process of updating its IIJA investment commitments and the figures and percentages below may change.

**Table 1**

	(a)	(b)
	<b>Project Description</b>	<b>Potential Reimbursement</b>
1	Transformer Upgrades	\$ 5,838
2	East Providence Substation	\$ 180,148
3	Warren Substation Expansion	\$ 90,420
4	Warren Substation D Line	\$ 178,767
5	New Lafayette	\$ 105,087
6	Blanket - New Business Commercial	\$ 5
7	Blanket Project - Damage / Failure	\$ 1,782
8	Reliability Blanket	\$ 350,036

Prepared by or under the supervision of: Eric Wiesner (as to parts a. and b.)  
and Jeffrey Oliveira (as to part c.)

In Re: Proposed FY 2027 Electric Infrastructure, Safety and Reliability Plan  
Responses to the Commission’s First Set of Data Requests  
Issued on January 27, 2026

PUC 1-9, page 2

	(a)	(b)
	<b>Project Description</b>	<b>Potential Reimbursement</b>
9	Load Relief Blanket	\$ 169,988
10	Tiverton D-Line	\$ 30,074
11	Hopkins Hill - Damage / Failure	\$ 135,630
12	Apponaug Substation	\$ 9
13	Providence Study - Phase 2	\$ 327
14	Eldred 45J3 Reconductoring	\$ 141
15	Dexter 36W44 Asset Replacement	\$ 14,307
16	Crossman St #111 Sub (D-Line)	\$ 13,053
17	Lafayette 30F2 Feeder Tie	\$ 21,921
18	Wakefield 17F2 Feeder Upgrades	\$ 68
19	65J2 Feeder Upgrades	\$ 20,802
20	Wakefield 17F3 Feeder Relief	\$ 1,933
21	Peacedale 59F3 Feeder	\$ 1,162
22	Electromechanical Relay Program	\$ 848,927
23	Bristol D-Line & D-Sub	\$ 42,559

- c. The Company would include any IIA funding to offset the investments that had been included in rates. Depending on the timing of receiving IIA funding, the Company would reflect this in the Company’s Plan Reconciliation Filing or it would make the appropriate adjustment in any of the Company’s future Infrastructure, Safety, and Reliability (“ISR”) filings. See also the Company’s response to Data Request Division 4-10 in this docket.

PUC 1-10  
**Pole Attachments**

Request:

In Division 1-27, the question began with: Explain in detail why the Company believes it must absorb more cost associated with third party attachments. On Bates page 104, the Company stated that the FCC “has clarified in recent rulings that utilities cannot allocate all of the costs of a pole replacement to the pole attacher ‘in any situation where the pole already requires replacement before a new attachment request is made, including when poles are out of compliance with current safety and utility construction standards.’”

- a. Is the Company contending that FY 2027 is the first time it is being held to the above-referenced standard? If so, please explain how the quoted standard is different from the *2021 Pole Replacement Declaratory Ruling*, 36 FCC Rcd 7766, n.450.
- b. What is the total number of poles impacted by the proposed project? What percentage of total Rhode Island Energy-owned poles are impacted?
- c. Has the Company inventoried its poles that would have new attachments under the proposed project?
- d. If so, how many poles does the Company estimate will need to be replaced?
- e. Other than the number of poles involved in the referenced attachment request, what has changed since the FCC ruling in 2023 to warrant special treatment of pole replacements in this ISR?

Response:

- a. No, the Company does not contend that FY 2027 is the first time in which it is being held to the FCC's standard for pole replacement cost sharing; however, FY 2027 is the first ISR fiscal year in which the Company is anticipating a significant increase in pole attachment work as a result of GoNetSpeed's expansion throughout the state, which potentially will increase significantly the Company's costs for this work as compared to prior ISR Plans. The Company is invoicing existing attachers who the Company believes have caused pre-existing violations resulting in pole failures requiring replacement. However, as the Connecticut Public Utilities Regulatory Authority (“PURA”) has determined, “it may not always be reasonable to identify the creator of any specific violation; indeed, it would be too time consuming and difficult, and often impossible, to identify the source of the

PUC 1-10, page 2

violation.”<sup>1</sup> In addition, a recent FCC decision granting a complaint by Comcast Cable Communications, LLC, a cable and internet provider, against Appalachian Power Company in Virginia makes clear that when a new attacher seeks access to a pole that must be replaced because it has preexisting safety violations, the new attacher cannot be charged the cost to replace the pole to correct the violation and may only be charged the incremental cost between a replacement pole sufficient to correct the violation and a pole taller than that (if necessary) that would also make room for the new attacher.<sup>2</sup> In many cases, the incremental cost is modest. Considering such potential disputes regarding who may have caused a violation, there is a considerable risk that the existing attachers do not pay these invoices, thereby requiring those costs be borne by the Company. The Company is proposing that these costs get reconciled through the appropriate ISR reconciliation mechanism as outlined in part e.

- b. The GoNetSpeed project currently has 2,820 total poles; however, only 1,566 poles contain complex make ready work including 517 poles that will need to be replaced. These replacements account for approximately 0.2 percent of poles within the Rhode Island Energy service territory. However, GoNetSpeed has confirmed that it plans to expand service into adjacent communities over the course of the next fiscal year, which will increase the pole replacements beyond this forecast.
- c. Yes, the total number of poles getting a new GoNetSpeed attachment for this project is 2,820 poles.
- d. Of the total poles applied to for this project, 517 poles will be replaced.
- e. The Company is not requesting special rate treatment for third party attachment costs. Rather, the Company proposes moving third-party attachments outside of the Soft-Cap budget category because the Company and the Division are concerned about the uncertainty in the timing and the amount of costs the Company will incur for this program and the extent to which it will be able to hold existing attachers responsible for a share of those costs. As discussed above, the Company is aware of plans for broadband companies, such as GoNetSpeed to expand across the state, which the Company is forecasting to increase significantly such that it would begin to impact safety and reliability programs

---

<sup>1</sup> Connecticut Public Utilities Regulatory Authority, Docket No. 19-01-52RE01, *PURA Investigation of Developments in the Third-Party Pole Attachment Process – Make-Ready* at 44 (May 11, 2022).

<sup>2</sup> Federal Communications Commission, Proceeding No. 25-330, *In the Matter of Comcast Cable Communications, LLC v. Appalachian Power Company* at 2, 7-9, 18-19 (February 5, 2026)

PUC 1-10, page 3

within the Soft-Cap budget category. It is unusual for the Company to receive requests comparable in size and scale to the GoNetSpeed project. Most typical applications the Company receives range from one to two poles, up to 90 poles. This project alone was 2,820 pole attachments. In addition to the ongoing project, and as stated in part b., the Company has been made aware that there are additional plans to expand infrastructure into adjacent communities. With the limited control that the Company has in the timing of execution upon these requests, it makes it challenging for the Company to accurately forecast spending. To address these concerns, the Company is proposing a separate contingency category for third-party attachments, such that the Company has not included the proposed spending in the forecasted plant in service amounts for FY 2027, and thus, there is no immediate impact on rates; however, the Company proposes that it be allowed to include any spending that it actually incurs in FY 2027 for pole replacements that it is not able to charge to existing attachers in the FY 2027 reconciliation, and such spending would not be subject to the Soft-Cap budget limit.

PUC 1-11  
**Pole Attachments**

Request:

Please provide the following information:

- a. What is PPL's criteria for replacing distribution poles in each of the three jurisdictions (PA, KY, and RI) that PPL operates in?
- b. What is the current height requirement for the types of poles impacted by the referenced project in Rhode Island? What would be the comparable pole heights in Pennsylvania and Kentucky?
- c. When was the last time the Rhode Island Energy changed its internal construction standards for its pole replacement standards, pole safety standards, and pole construction standards?

Response:

- a. When it comes to pole attachments or when an entity applies to attach to a Company owned pole, poles are replaced if they either fail pole loading analysis or there is a clearance issue that cannot be resolved by simply rearranging cables on the pole. Additionally, any pole that is found to be visually failing or rotting, when the pole is being surveyed for the application, will be replaced. This criteria is the same across PPL's three jurisdictions.
- b. The most common minimum pole height, especially for any three phase poles, is 45 feet, although there are cases where single phase pole lines can have 40-foot pole heights as the minimum. This height allows for a portion of the pole to be placed into the ground while providing sufficient height above the pole for any transformers, secondary wire, and a handful of attaching entities. Additional clearance may be required to cross roads, properties, or other external reasons. Please see Attachment PUC 1-11-1 for Rhode Island Energy's current Overhead Construction Standard; the document outlines Company standards for a variety of scenarios. The Pennsylvania and Kentucky operating companies each have specific local distribution standards; however, electrical clearances are driven by national codes and OSHA safety standards and, therefore, the pole heights are consistent across the three operating companies in Rhode Island, Pennsylvania and Kentucky.
- c. The Company recently implemented an extreme wind loading review when designing a pole replacement due to storm hardening efforts. The updated standard is shown in Attachment PUC 1-11-2. This change was implemented in 2025.

Supersedes 7/08 - --Revised clearance to swimming pools.

SECTION	PAGE
• 7.0 INTRODUCTION	7-1
• 7.1 GENERAL	7-1 THRU 7-5
• 7.2 RELATIVE LEVELS	7-5
• 7.3 CLEARANCES OF SUPPORTING STRUCTURES FROM RAIL, CURB, HYDRANT & OTHER OBJECTS	7-5 THRU 7-6
• 7.4 VERTICAL CLEARANCE TO GROUND, ROAD, RAILS, ETC.	7-6 THRU 7-9
• 7.5 VERTICAL CLEARANCE OF WIRES, CONDUCTORS AND CABLES ABOVE WATER SURFACES	7-9 THRU 7-10
• 7.6 CLEARANCE TO SWIMMING POOLS	7-10 THRU 7-12
• 7.7 VERTICAL & HORIZONTAL CLEARANCE OF WIRES, CONDUCTORS AND CABLES TO RAIL CARS	7-12 THRU 7-13
• 7.8 VERTICAL CLEARANCE OF EQUIPMENT CASES AND RIGID LIVE PARTS OF EQUIPMENT MOUNTED ON STRUCTURES	7-13 THRU 7-14
• 7.9 CLEARANCE OF WIRES, CONDUCTORS, CABLES AND UNGUARDED LIVE PARTS TO BUILDINGS & OTHER INSTALLATIONS EXCEPT BRIDGES	7-14 THRU 7-18
• 7.10 CLEARANCE TO BRIDGES	7-18 THRU 7-19
• 7.11 SEPARATION OF CONDUCTORS AND SUPPORTS ON THE SAME POLE	7-20 THRU 7-24
• 7.12 CLEARANCE TO PROPERTY LINE	7-25
• 7.13 VERTICAL CLEARANCE BETWEEN WIRES, CONDUCTORS & CABLES AT POINT OF CROSSING DIFFERENT SUPPORTING STRUCTURES	7-25 THRU 7-26
• 7.14 CLEARANCES OF VERTICAL & LATERAL SUPPLY CONDUCTORS FROM OTHER WIRES & SURFACES OF THE SAME STRUCTURE	7-26
• CONSTRUCTION DRAWINGS	
○ Increased Horizontal Clearance For All Span Lengths	7-124
○ Climbing Space	7-127
○ BIL & Air – Wood Spacing	7-128



This page left intentionally blank.

## 7.0 INTRODUCTION

### 7.0.10 Role of the National Electrical Safety Code

The National Electrical Safety Code (NESC) provides basic guidance for minimum clearances to protect the public and employees during the installation, maintenance and operation of electric supply and communication lines, and associated equipment. The NESC is not intended as a design specification or an instruction manual.

### 7.0.20 Role of this Standard

This standard is intended as a design specification to provide for compliance with the NESC, safe installation, operation and maintenance of lines, an adequate level of service reliability, and space for future equipment or conductors. New poles shall be selected to meet or exceed the clearances shown, which shall be considered as minimum requirements.

### 7.0.30 Clearance Requirements for Distribution Lines

Each vertical and horizontal clearance shall be observed, but within the limits of each other only.

The uniform clearance system contained in the NESC is based on the dimensions of the expected activities in each area, as well as the relative potential problem caused by each type of facility.

Conductor clearance is stated in terms of the "closest approach." This is the clear distance between surfaces that **must** be maintained under specified conditions.

In general, vertical clearance requirements must be met during maximum sag conditions to provide for the expected activity beneath the line.

In general, horizontal clearance requirements must be met with the conductor at rest to provide for the expected activity alongside the line. Conductor "blowout" (wind displacement) is considered under certain conditions (refer to Sections 7.9, 7.10 and 7.13).

## 7.1 GENERAL

### 7.11.10 PPL Clearance Criteria for Distribution Lines

- A. Overhead distribution lines shall be designed to maintain adequate clearances under ice loaded conditions and the line's maximum conductor operating temperature (MCOT). In no case should a distribution line be designed for a MCOT below 120°F/48.9°C.
- B. The required MCOT of the distribution line shall be determined by the appropriate planning department.
- C. To protect conductors from damage caused by excessive heating, the required MCOT for the distribution shall not exceed the following limits:
  - i. 176°F/80°C for primary bare conductors 35 kV and below,
  - ii. 167°F/75°C primary covered conductors 35 kV and below,
  - iii. 120°F/48.9°C for spacer cable messengers and 167°F/75°C for spacer cable phase conductors (Phase conductor temperatures higher than 120°F/50°C are taken to have no influence in elevating messenger temperatures),
  - iv. Primary shielded and non-shielded aerial cables 35 kV and below shall be designed to operate with the messenger at 120°F/48.9°C ambient (Phase

Supersedes 7/08 Issue – Deleted reference to nonexistent EOP in 7.0.30.

Supersedes 1/06 Issue – Editorial and paging revisions.

Supersedes 1/06 Issue – Fiber-optic cable information updated.

- conductor temperatures higher than 120°F/48.9°C are taken to have no influence in elevating messenger temperatures), and
- v. Secondary non shielded cables 0 to 750 V shall be designed to operate with the messenger at 120°F/48.9°C ambient (Temperatures of the insulated conductors, lashed or twisted about the messenger, above 120°F/48.9°C, are taken to have no influence in elevating messenger temperatures).
- D. New Installations and Extensions - Clearances for the installation of all new electric supply lines and extensions to existing lines shall be in accordance with the latest edition of the NESC and the requirements of any applicable state or local laws, rules or regulations.
  - E. Existing Installations - Where an existing installation meets, or is altered to meet, the current NESC Rules, such installation is considered to be in compliance with the current edition of the NESC and is not required to comply with any previous edition of the NESC.
  - F. Existing installations, including maintenance replacements, that currently comply with prior editions of the NESC, need not be modified to comply with these rules except as may be required for safety reasons by the administrative authority.
  - G. Where conductors or equipment are added, altered, or replaced on an existing structure, the structure or the facilities on the structure need not be modified or replaced if the resulting installation will be in compliance with either (a) the NESC rules that were in effect at the time of the original installation, (b) the rules in effect in a subsequent edition of the NESC to which the installation has been previously brought into compliance, or (c) rules in the latest edition of the NESC.
  - H. Clearances listed in the following STANDARDS and tables are considered minimum requirements for new construction. In some instances clearances exceeding those given may be required (e.g. when mandated by local ordinances). Other design considerations applying to Company work and operating practices may result in clearances greater than NESC minimum clearances. For example, vertical clearances for 34.5 kV grounded wye construction are based on pre-1987 codes, which called for 40 inch phase to neutral clearance at the pole and 30 inch phase to neutral clearance mid-span for spans up to 175 feet. These added clearances are deemed more prudent for hot-stick operation and maintenance of 25 kV and 35 kV constructions.
  - I. Effectively grounded circuits are defined as those circuits originating from a grounded-wye connected transformer or system, or from a system provided with a grounding transformer of sufficient size to stabilize the phase to ground voltage at approximately its normal value, regardless of whether the neutral conductor is present with the circuit. Circuits having a maximum  $X_0/X_1$  ratio of 3.0 at the substation bus are considered effectively grounded circuits.
  - J. Voltage is the root-mean-square (rms) potential difference between any two conductors or between a conductor and ground. Voltages are expressed in nominal values unless otherwise indicated. Nominal voltage is the value assigned to a system or circuit of a given voltage class for the purpose of convenient designation. Operating voltage of the system may vary above or below the nominal voltage.
  - K. Voltages in the following tables are phase to ground, unless otherwise noted, for effectively grounded circuits and those other circuits where all ground faults are cleared by promptly de-energizing the faulted section, both initially and following subsequent breaker operations. "Effectively grounded" means intentionally connected to earth through a ground connection or connections of sufficiently low impedance and having

sufficient current-carrying capacity to limit the buildup of voltages to levels below that which may result in undue hazard to persons or to connected equipment. The voltage of a circuit not effectively grounded is the highest nominal voltage available between any two conductors on the circuit.

- L. Clearance is defined as the clear distance between two objects measured surface to surface.
- M. Spacing is defined as the distance between two objects measured center to center.
- N. Clearances for tree wire, covered conductor, and spacer cable conductor are taken as if they were bare conductors.
- O. Open conductors are defined as electric supply or communication construction in which the conductors are bare, covered or insulated and without grounded shielding, or individually supported at a structure either directly or with insulators.
- P. Electric supply lines are those conductors used to transmit electric energy and their necessary supporting or containing equipment.
- Q. Communication conductors include fire alarm, telephone, cable television, police alarm, data, telegraph, clock, and other systems used for communication service.
- R. Fiber-Optic Cables in the supply space:

There are two general categories:

1. Fiber optic cables supported by an effectively ground metallic messenger.
2. All dielectric fiber optic (ADFO) cable.

Clearance requirements:

1. ADFO cables (i.e. meeting NESC Rule 230F1b) installed in the supply space have no specified clearances from supply conductors and other cables in the supply space.
2. Fiber optic cables supported by an effectively ground metallic messenger (i.e. meeting NESC Rule 230F1a) and ADFO cables (i.e. meeting NESC Rule 230F1b) are prohibited from being installed in the Communication Worker Safety Zone between the supply space and the communication space, but may be treated the same as effectively grounded neutrals for clearance purposes.

7.1.20 **NESC Vertical Clearance Requirements Illustration – Rules 232 & 235**

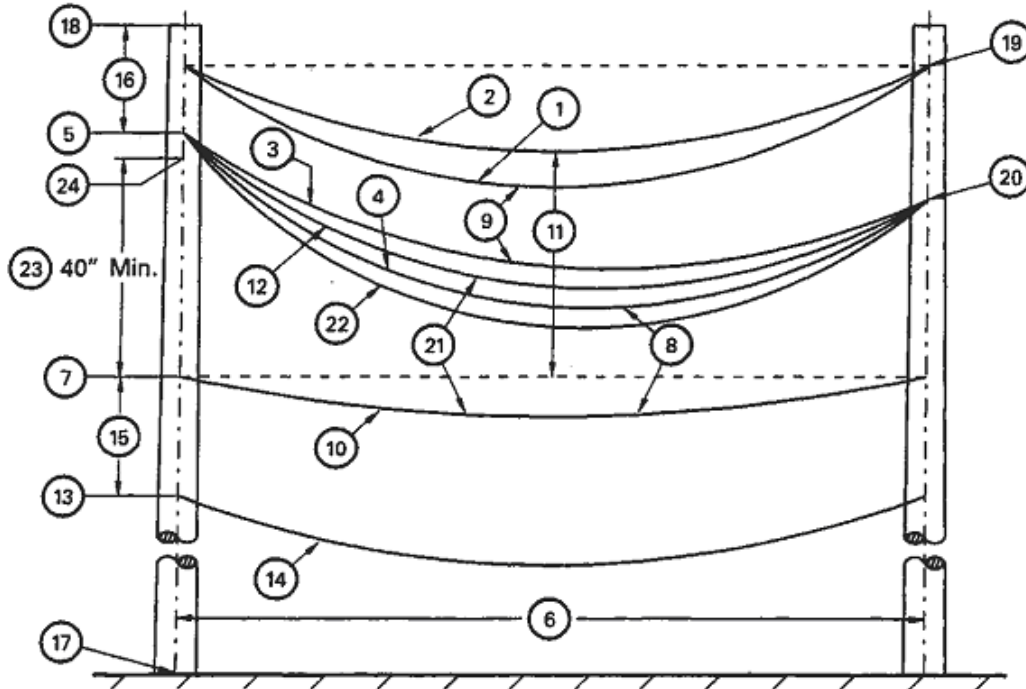

**Figure 1**

- 1 - Lowest upper supply conductor at position which produces maximum final sag; effectively grounded circuits 0-22 kV phase to ground.
- 2 - Lowest upper supply conductor at 60°F/15°C, final, unloaded sag; effectively grounded circuits 0-22 kV phase to ground
- 3 - Secondary cable, 0-750 V, supported by effectively grounded messenger; messenger at same operating ambient as 1 above.
- 4 - Effectively grounded neutral associated with 1 above.
- 5 - Lowest electrical point of attachment.
- 6 - Actual span length.
- 7 - Highest communication conductor attachment.
- 8 - May be reduced to 12 inches for effectively grounded neutral conductors, associated with circuits 0-22 kV phase to ground.
- 9 - Clearance in-span primary to secondary; must be 75% of that required at support, all span lengths.
- 10 - Highest communication conductor, Company design based on fire alarm pair or single telephone loop with midspan sag; 4 inches for 0 to 150 feet; 6 inches for 150 to 200 feet; 8 inches for 200 to 250 feet; and 12 inches for 250 to 300 feet; all ambients.

Supersedes 1/06 Issue – Editorial and paging revisions.

Supersedes 1/06 Issue – Editorial and paging revisions.

- 11 - For spans exceeding 150 feet, vertical clearances at the pole between the open supply conductors of over 750 V, but less than 50 kV, and the highest communication conductor, shall be adjusted, so that under conditions of both conductors at 60°F/15°C, no wind, and final unloaded sag, no point in the top supply conductor span shall be below a straight line joining the support points of the highest communication conductor.
- 12 - Secondary cable, 0-750 V, supported by effectively grounded messenger; at position which produces maximum final sag.
- 13 - Lowest communication conductor attachment.
- 14 - Lowest communication conductor.
- 15 - Communication conductor allocated space.
- 16 - Electric conductor allocated space.
- 17 - Final grade.
- 18 - Top of pole structure.
- 19 - Primary conductor attachment.
- 20 - Secondary cable or neutral attachment.
- 21 - Clearance in-span, secondary to top communication conductor; must be 75% of that required at support; all span lengths.
- 22 - Effectively grounded neutral conductor associated with top primary conductor; neutral at maximum sag condition.
- 23 - At pole clearance may be reduced to 30 inches from bottom of grounded non-current carrying equipment, such as transformers, capacitors and voltage regulators.
- 24 - Lowest electrical ownership.

## 7.2 **RELATIVE LEVELS**

Where supply lines of different voltages are attached to the same pole or cross one another, the higher voltage conductors should, where practical, be placed above those of lower voltage.

## 7.3 **CLEARANCES OF SUPPORTING STRUCTURES FROM RAIL, CURB, HYDRANT & OTHER OBJECTS**

Poles for overhead distribution lines shall be located with adequate clearance to railroad and automobile traffic. The following table demonstrates NESC minimum requirements. These requirements should be exceeded if practicable. State authorities prefer that poles be set back as far as possible from the pavement edge, behind guard rails, back of the ditch, behind sidewalks, curbs, etc. In any case, the approval of the authorities shall be obtained. Avoid poles at exposed corners and similar locations where they are likely to be struck by motor vehicles or snow removal equipment.

**Table 1**  
**Clearance of Supporting Structures from Rail, Curb or Hydrant**  
**(Reference: NESC Rule 231)**

Supporting structures<sup>1</sup>, support arms, attached equipment, and braces shall have the following clearances (in feet) measured between the nearest parts of the objects concerned:

<b>Objects</b>	<b>Minimum (Ft.)</b>	<b>Recommended (Ft.)</b>
A. Fire Hydrants	3 <sup>2</sup>	4 <sup>2</sup>
B. Streets, Roads, Highways <sup>3</sup>	<b>Horizontal Clearance for First 15 Feet Above Ground</b>	
1. With street curbs (clearance measured from street side of the curb)		
a. Arterial Streets which are primarily for through traffic	0.5	2 <sup>4</sup>
b. Local Streets which are primarily for access to residences, business or other abutting property	0.5	1 <sup>2</sup>
2. With no curbs		See Note 5
C. All Railroad Tracks	<b>Horizontal Clearance for First 22 Feet Above the Nearest Track Rail</b>	
	12 <sup>6</sup>	

**FOOTNOTES:**

1. Supporting structures are defined as the main supporting unit, usually a pole or tower.
2. This clearance also applies to anchor guys and push braces.
3. Where a governmental authority exercising jurisdiction over structure location has issued a permit for, or otherwise approved, specific locations for supporting structures, that permit or approval shall govern.
4. Place the supporting structures as far as practical behind the curb within the road right-of-way.
5. Place the supporting structures a sufficient distance from the roadway to avoid contact by ordinary vehicles using the traveled way.
6. This may be reduced to 7 feet where the supporting structure is not the controlling obstruction, provided sufficient space for a driveway is left where the cars are loaded and unloaded.

**7.4 VERTICAL CLEARANCES OF WIRES, CONDUCTORS, CABLES, AND EQUIPMENT ABOVE GROUND, ROADWAY, RAILS, ETC.**

Clearances for distribution conductors, found in Table 2, above ground, rails, etc., are based on a conductor temperature of 60°F/15°C, no wind.



- i. 18 feet for: wires carrying less than 750 volts; guys, message wires, and communication cables; supply cables encased in a continuous metal sheath; and insulated supply cables fastened to an effectively grounded messenger cable,
- ii. 20 feet for wires carrying more than 750 volts to 15,000 volts,
- iii. 22 feet for wires carrying more than 15,000 volts to 50,000 volts, and
- iv. 22 feet plus 4/10 inch for each 1,000 volt increase for wires carrying more than 50,000 volts.

**Table 2**  
**Minimum Vertical Clearance of Wires, Conductors, and Cables Above Ground, Roadways, or Rails**  
**(Reference: NESC Table 232-1)**

Column	Section Heading
1	Grounded guys; messengers, surge protection wires; grounded neutrals; shielded supply cables supported by grounded messenger; ungrounded guys exposed to 0- to 300 V <sup>11,15</sup> ; and insulated communication cables and conductors
2A	Non-shielded supply cables, 0 to 750 V, supported by grounded messenger
2B	Non-insulated communication conductors
3	Open supply conductors 0 to 750 V; non-shielded supply cables supported by grounded messenger under 5 kV <sub>Ø-Ø</sub> or 2.9 kV <sub>Ø-G</sub> ; ungrounded guys exposed to over 300 V to 750 V <sup>14</sup>
4	Open supply conductors over 750 V-22 kV; ungrounded guys exposed to 750 V to 22 kV <sup>14</sup>

Nature of Surface Underneath Wires, Conductors, or Cables	1	2A	3	4
	(ft.)	(ft.)		
<b>Where wires, conductors, or cables cross over or overhang</b>				
1. Track rails of railroads (not using overhead electric supply conductors) <sup>2,16</sup>	23.5	24.0	24.5	26.5
2. Roads, streets, and other areas subject to truck traffic <sup>3</sup>	15.5	16.0	16.5	18.5
3. Driveways, parking lots, and alleys <sup>23</sup>	15.5 <sup>7,13</sup>	16.0 <sup>7,13</sup>	16.5 <sup>7</sup>	18.5
4. Land traversed by vehicles, such as cultivated, grazing, forest, orchards, etc. <sup>26</sup>	15.5	16.0	16.5	18.5
5. Spaces and ways subject to pedestrians or restricted traffic only <sup>9</sup>	9.5	12.0 <sup>8</sup>	12.5 <sup>8</sup>	14.5
<b>Where Wires, Conductors Or Cables Run Along Highway Or Rights-Of-Way But Do Not Overhang The Roadway</b>				
Nature of Surface Underneath Wires, Conductors, or Cables	1	2A	3	4
	(ft.)	(ft.)		
6. Roads, streets, or alleys	15.5 <sup>24</sup>	16.0	16.5	18.5
7. Roads in rural districts where it is unlikely that vehicles will be crossing under the line	13.5 <sup>10,12</sup>	14.0 <sup>10</sup>	14.5 <sup>10</sup>	16.5

**Note:**

For voltages exceeding 22 kV, increase clearances specified above at a rate of 0.4 inches per kV in excess of 22 kV (reference NESC Rule 232C2a).

**FOOTNOTES:**

**Note:** Footnotes 1, 4-6, 17-22, and 25, are not used.

2. For wires, conductors, or cables crossing over mine, logging, or similar railways that handle only cars lower than standard freight cars, the clearance may be reduced by an amount equal to the difference in height between the highest loaded car handled and 20 feet, but the clearance shall not be reduced below that required for street crossings
3. Does not include neutral conductors effectively ground throughout their length and associated with circuits of 0 to 22 kV phase to ground (i.e. meeting NESC Rule 230E1).

Supersedes 1/06 Issue – Editorial and paging revisions.

7. Where vehicles exceeding 8' in height are not normally encountered nor reasonably anticipated, service drop(s) clearances over residential driveways only may be reduced to the following:

	<b>Feet</b>
Insulated supply service drops limited to 300 V to ground	12.5
Insulated drip loops of supply service drops limited to 300 V to ground	10.5
Supply service drops limited to 150 V to ground that are insulated and cabled together with an effectively grounded bare messenger or neutral (i.e. meeting NESC Rule 230C3)	12.0
Drip loops only of service drops limited to 150 V to ground that are insulated and cabled together with an effectively grounded bare messenger or neutral (i.e. meeting NESC Rule 230C2 or 230C3)	10.0
Insulated communication service drops	11.5

8. These clearance values for service drops to residential buildings only may be reduced to the following:

	<b>Feet</b>
Insulated supply service drops limited to 300 V to ground	10.5
Insulated drip loops of supply service drops limited to 300 V to ground	10.5
Supply service drops limited to 150 V to ground that are insulated and cabled together with an effectively grounded bare messenger or neutral (i.e. meeting NESC Rule 230C3)	10.0
Drip loops only of service drops limited to 150 V to ground that are insulated and cabled together with an effectively grounded bare messenger or neutral (i.e. meeting NESC Rule 230C1 or 230C3)	10.0

9. Spaces and ways subject to pedestrians or restricted traffic only are those where riders on horseback or other large animals, vehicles, or other mobile units exceeding 8 feet in height, are prohibited by regulation or permanent terrain configurations or are otherwise not normally encountered nor reasonably anticipated.
10. Where a supply or communication line along a road is located relative to fences, ditches, embankments, etc., so that ground under the line would not be expected to be traveled except by pedestrians, the clearances may be reduced to the following values:

	<b>Feet</b>
Insulated communication conductor and communication cables	9.5
Conductors of other communication circuits	9.5
Lashed aerial cables (insulated and fully metallic shielded) installed according to these standards and cabled together with an effectively grounded bare messenger or neutral (i.e. meeting NESC Rule 230C1), supply cables limited to 150 V to ground that are insulated and cabled together with an effectively grounded bare messenger or neutral (i.e. meeting NESC Rule 230C2 or 230C3), and neutral conductors that are effectively ground throughout their length and associated with circuits of 0 to 22 kV phase to ground (i.e. meeting NESC Rule 230E1)	9.5
Insulated supply conductors limited to 300 V to ground	12.5
Guys	9.5

11. No clearance from ground is required for anchor guys not crossing tracks, rails, streets, driveways, roads, or pathways.
12. This clearance may be reduced to 13 feet for communication conductors and guys.
13. Where this construction crosses over or runs along alleys, driveways, or parking lots not subject to truck traffic, this clearance may be reduced to 15 feet.

Supersedes 7/08 Issue – Revised Footnotes 7 and 8 to reflect 2017 NESC revisions.

14. Ungrounded guys and ungrounded portions of span guys between guy insulators shall have clearances based on the highest voltage to which they may be exposed due to slack conductor or guy.
15. Anchor guys insulated in accordance with these standards may have the same clearance as grounded guys.
16. Adjacent to tunnels and overhead bridges that restrict the height of loaded rail cats to less than 20 feet, if mutually agreed to by the parties at interest.
23. For the purpose of this Rule, trucks are defined as any vehicle exceeding 8 feet in height. Areas not subject to truck traffic are areas where truck traffic is not normally encountered nor reasonably anticipated.
24. Communication cables and conductors may have a clearance of 15 feet where poles are in back of curbs or other deterrents to vehicular traffic.
26. When designing a line to accommodate oversized vehicles, these clearance values shall be increased by the difference between the known height of the oversized vehicle and 14 feet.

**7.5 VERTICAL CLEARANCE OF WIRES, CONDUCTORS AND CABLES ABOVE WATER SURFACES**

Vertical clearances of distribution supply wires and conductors over waterways shall not be less than those shown on Table 3: Vertical Clearance Above Water Surfaces. Where the U.S. Army Corps of Engineers has issued a crossing permit, clearances of that permit shall govern, if greater.

**Table 3  
Vertical Clearance Above Water Surface (Reference: NESC Table 232-1)**

Column	Section Heading
1	Insulated communication conductors and cable; messengers; surge-protection wires; grounded guys; ungrounded guys exposed to 0 to 300 V <sup>11,15</sup>
2	Non-insulated communication conductors; and non-shielded supply cables 0 to 750 V supported by grounded messenger
3	Open supply conductors 0 to 750 V; non-shielded supply cables supported by grounded messenger under 5 kV <sub>φ-φ</sub> or 2.9 kV <sub>φ-G</sub> ; ungrounded guys exposed to over 300 V to 750 V <sup>14</sup>
4	Open supply conductors over 750 V to 22 kV; ungrounded guys exposed to 750 V to 22 kV <sup>14</sup>

Nature of Surface Underneath Wires, Conductors, or Cables	1	2	3	4
	(ft.)	(ft.)	(ft.)	(ft.)
<b>Where wires, conductors, or cables cross over or overhang</b>				
1. Water areas not suitable for sailboating or where sailboating is prohibited <sup>21</sup>	14.0	14.5	15.0	17.0
2. Water areas suitable for sailboating including lakes, ponds, reservoirs, tidal waters, rivers, streams, and canals with an unobstructed surface area of: 17,18,19,20,21				
a. Less than 20 acres	17.5	18.0	18.5	20.5
b. Over 20 to 200 acres	25.5	26.0	26.5	28.5
c. Over 200 to 2000 acres	31.5	32.0	32.5	34.5
d. Over 2000 acres	37.5	38.0	38.5	40.5

**Notes:**

- (a) Clearances may be reduced under certain conditions. See NESC Rule 232.

Supersedes 1/06 Issue – Editorial and paging revisions.

Supersedes 7/08 Issue – Editorial and paging revisions.

**FOOTNOTES:**

**Note:** Footnotes 1-10, 12, 13, and 16 will not be used.

11. No clearance from ground is required for anchor guys not crossing tracks, rails, streets, driveways, roads, or pathways.
14. Ungrounded guys and ungrounded portions of span guys between guy insulators shall have clearances based on the highest voltage to which they may be exposed due to a slack conductor or guy.
15. Anchor guys insulated in accordance with these standards may have the same clearance as grounded guys.
17. For controlled impoundments, the surface area and corresponding clearances shall be based upon the design high-water level.
18. For uncontrolled water flow areas, the surface area shall be that enclosed by its annual high-water mark. Clearances shall be based on the normal flood level; if available, the 10-year flood level may be assumed as the normal flood level.
19. The clearance over rivers, streams, and canals shall be based upon the largest surface area of any 1 mile long segment that includes the crossing. The clearance over a canal, river, or stream normally used to provide access for sailboats to a larger body of water shall be the same as that required for the larger body of water.
20. Where an over-water obstruction restricts vessel height to less than the applicable reference height given in NESC Table 232-3, the required clearance may be reduced by the difference between the reference height and the over-water obstruction height, except that the reduced clearance shall not be less than that required for the surface area on the line crossing side of the obstruction.

**7.6 CLEARANCE TO SWIMMING POOLS**

Service drops or other supply wires and conductors should not pass over a swimming pool or the surrounding land within 25 feet around the edge of the pool. If such crossings cannot be avoided, the clearances shown below shall be obtained. For all spans, horizontal clearances must be increased as shown on Page 7-124. For information on other requirements and relocation policy refer to Specifications for Electrical Installations (ESB 750).

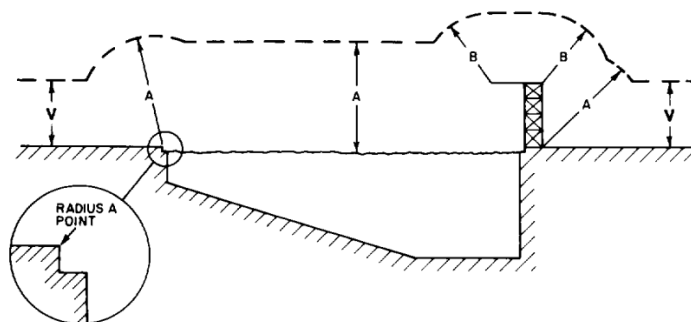

**Figure 3**

**Table 4**  
**Clearance to Swimming Pools**  
(Reference: NESC Table 234-3, Figure 234-3, Rules 232 and 234)

Column	Section Heading
1	Insulated communication conductors and cables; messengers; surge-protection wires; grounded guys; ungrounded guys exposed to 0-300 V <sup>3</sup> ; neutral conductors that are effectively ground throughout their length and associated with circuits of 0 to 22 kV phase to ground (i.e. meeting NESC Rule 230E1); lashed aerial cables (insulated and fully metallic shielded) installed according to these standards and cabled together with an effectively grounded bare messenger or neutral (i.e. meeting NESC Rule 230C1)
2	Unguarded rigid live parts, 0 to 750 V; non-insulated communication conductors; supply cables of 0 to 750 V that are insulated and cabled together with an effectively grounded bare messenger or neutral (i.e. meeting NESC Rule 230C2 or 230C3); ungrounded guys exposed to open supply conductors of over 300 V to 750 V <sup>2</sup>
3	Supply cables over 750 V and under 5 kV phase-to-phase or 2.9 kV phase-to-ground that are insulated and cabled together with an effectively grounded bare messenger or neutral (i.e. meeting NESC Rule 230C2 or 230C3); open supply conductors, 0 to 750 V
4	Unguarded rigid live parts over 750 V to 22 kV; ungrounded guys exposed to over 750 V to 22 kV <sup>2</sup>
5	Open supply conductors, over 750 V to 22 kV

	Column 1 (ft) <sup>7</sup>	Column 2 (ft) <sup>8</sup>	Column 3 (ft)	Column 4 (ft)	Column 5 (ft)
A. Clearance in any direction from the water level, edge of pool, base of diving platform, or anchored raft	22.0	22.5	23.0	24.5	25.0
B. Clearance in any direction to the diving platform, tower, water slide or other fixed pool-related structures	14.0	14.5	15.0	16.5	17.0
V. Vertical clearance to adjacent land	*Clearances specified in Section 7.4*				

**FOOTNOTES:**

1. For voltages over 22 kV and up to 50 kV increase specified clearance at a rate of 0.4 inches per kV over 22 kV.
2. Ungrounded guys and ungrounded portions of guys between insulators shall have clearances based on the highest voltage to which they may be exposed due to a slack conductor or guy.
3. Anchor guys insulated in accordance with these standards may have the same clearance as grounded guys.
4. Where wires, conductors, cables, or unguarded rigid live parts are over a swimming pool or the surrounding area, clearances in any direction shall be as shown in the Figure 3 and Table 4 on Page 7-10. This rule does not apply to a pool enclosed by a solid or screened permanent structure.
5. If rescue poles are not used by lifeguards on supervised beaches and waterways, the clearances in Table 3 on Page 7-8 for appropriate land/water body shall be used.
6. Use clearances in Table 3 on Page 7-8 for waterways subject to waterskiing.
7. These clearance requirements do not apply when these facilities are 10 ft or more horizontally from the edge of the pool, diving platform, diving tower, water slide, or other fixed, pool-related structures.

Supersedes 7/08 Issue – Replaced footnote 7. Added footnote 8.

8. These clearance requirements do not apply for non-insulated communication conductors; supply cables of 0 to 750 V that are insulated and cabled together with an effectively grounded bare messenger or neutral (i.e. meeting NESC Rule 230C2 or 230C3); ungrounded guys exposed to open supply conductors of over 300 V to 750 V when these facilities are installed 10 ft or more horizontally from the edge of the pool, diving platform, diving tower, water slide, or other fixed, pool-related structures.
9. Use clearances in Table 3 on Page 7-8 for waterways subject to waterskiing.

**7.7 VERTICAL & HORIZONTAL CLEARANCE OF WIRES, CONDUCTORS AND CABLES TO RAIL CARS**

(Reference: NESC Rules 232, 234-1, 234I, Table 232-1, and Figure 234-5)

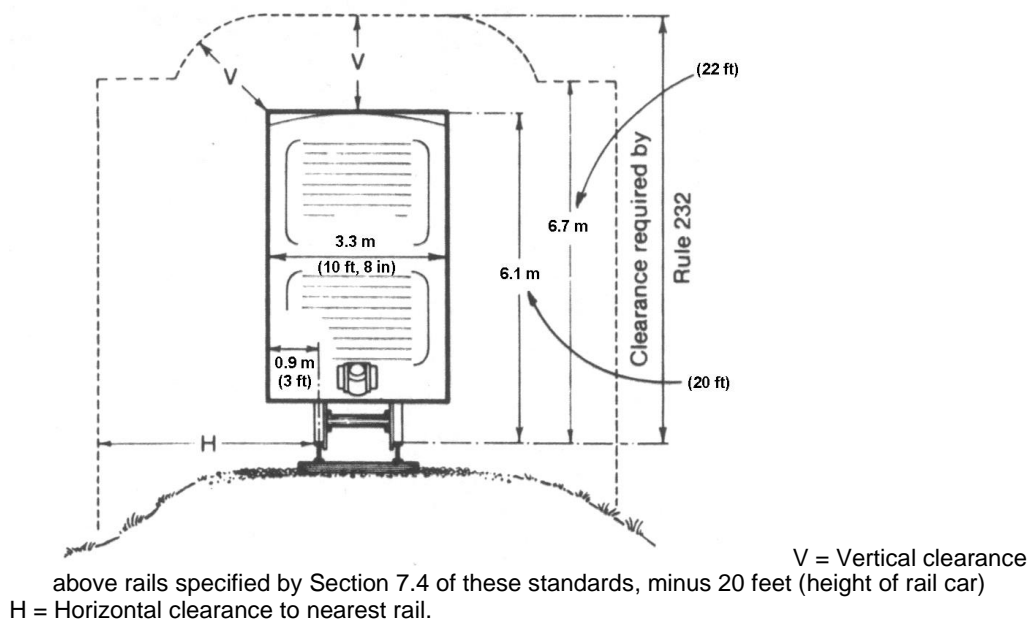

Overhead Wires, Conductors Or Cables	Clearance In Feet	
	V	H
Grounded Guys, Messengers, Surge Protection Wires, Grounded Neutrals, Shielded Supply Cables Supported By Grounded Messenger, Ungrounded Guys exposed to 0 to 300 V <sup>(e)</sup> And Insulated Communication Cables And Conductors	3.5	8.5
Non-shielded Supply Cables, 0 to 750 V, Supported By Grounded Messenger, Non-insulated Communication Conductors	4.0	9.0
Open Supply Conductors, 0 to 750 V, Non-shielded Supply Cables Supported By Grounded Messenger, Under 5 kV <sub>φ-φ</sub> , or 2.9 kV <sub>φ-g</sub> , Ungrounded Guys Exposed To Over 300 V to 750 V <sup>(f)</sup>	4.5	9.5
Open Supply Conductors Over 750 V to 22 kV; Ungrounded Guys Exposed To 750 V to 22 kV <sup>(f)</sup>	6.5	11.5

Supersedes 7/08 Issue – Modified footnote 7. Added footnote 8.

**Notes:**

- (a) If the Railroad crossed requires greater clearances than detailed in this Standard, the Railroad clearances shall apply.
- (b) Voltages are phase to ground for grounded circuits and those circuits where ground faults are cleared promptly by de-energizing the faulted section. For systems that are not effectively grounded, voltages are phase-to-phase.
- (c) Anchor guys shall not be located less than 12 feet from the nearest track rail.
- (d) Anchor guys insulated in accordance with these standards may have the same clearance as grounded guys.
- (e) Ungrounded guys and ungrounded portions of span guys between guy insulators shall have clearances based on the highest voltage to which they may be exposed due to slack conductor or guy.

**7.8 VERTICAL CLEARANCE OF EQUIPMENT CASES AND RIGID LIVE PARTS OF EQUIPMENT MOUNTED ON STRUCTURES**

**Table 5  
(Reference: NESC Rule 232B, Table 232-2)**

**Note** - These vertical clearances above ground or roadway surfaces are for unguarded rigid live parts such as potheads, transformer bushings, surge arresters, and short lengths of connecting supply conductors which are not subject to variations in sag.

Column	Section Heading
1	Nonmetallic or effectively grounded support arms, switch handles, platforms, braces, and equipment cases
2	Unguarded rigid live parts of 0 to 750 V and ungrounded cases that contain equipment connected to circuits of not more than 750 V
3	Unguarded rigid live parts of over 750 V to 22 kV and ungrounded cases that contain equipment connected to circuits of over 750 V to 22 kV

Nature of Surface Below	Clearance Above Ground or Roadway		
	Column 1 (ft.)	Column 2 (ft.)	Column 3 (ft.)
1. Where rigid parts overhang:			
a. Roads, streets and other areas subject to truck traffic <sup>4</sup>	15.0	16.0	18.0
b. Driveways, parking lots and alleys	15.0	16.0 <sup>6</sup>	18.0
c. Other land traversed by vehicles such as cultivated land, grazing land, forest, orchard, etc.	15.0 <sup>7</sup>	16.0	18.0
d. Spaces and ways subject to pedestrians or restricted traffic only <sup>5</sup>	11.0 <sup>7</sup>	12.0 <sup>1(b)</sup>	14.0
2. Where rigid parts are along and within the limits of highways or other road rights-of-way but do not overhang the roadway			
a. Roads, streets and alleys	15.0 <sup>7</sup>	16.0	18.0
b. Roads in rural districts where it is unlikely that vehicles will be crossing under the line	13.0 <sup>7</sup>	14.0 <sup>2</sup>	16.0

Supersedes 1/06 Issue – Editorial and paging revisions.

3. Water areas not suitable for sailboating or where sailboating in prohibited <sup>9</sup>	14.0	14.5	15.0
---------------------------------------------------------------------------------------------	------	------	------

**FOOTNOTES:**

**Note:** Footnotes 3, 6, and 8 will not be used.

1. For insulated live parts limited to 150 V, this clearance may be reduced to 10 ft.
2. Where a supply line along a road is limited to 300 V to ground and is located relative to fences, ditches, embankments, etc., so that the ground under the line would not be expected to be traveled except by pedestrians, this clearance may be reduced to 12 feet.
4. For the purpose of this rule, trucks are defined as any vehicle exceeding 8 feet in height. Areas not subject to truck traffic are areas where truck traffic is not normally encountered nor reasonably anticipated.
5. Spaces and ways subject to pedestrians or restricted traffic only are those areas where riders on horseback or other large animals, vehicles or other mobile units exceeding 8 feet in height, are prohibited by regulation or permanent terrain configurations or are otherwise not normally encountered nor reasonably anticipated.
- ↘ 6. This clearance may be reduced to the following values for driveways, parking lots, and alleys not subject to truck traffic:

	(ft)
a. Insulated live parts limited to 300 V to ground	12
b. Insulated live parts limited to 150 V to ground	10
- ↘ 7. Effectively grounded switch handles and supply or communication equipment cases (such as fire alarm boxes, control boxes, communication terminals, meters, or similar equipment cases) may be mounted at a lower level for accessibility provided such cases do not unduly obstruct a walkway. Switch handles and supply or communications shall be located so as not to serve as a means of approach to unguarded live parts by unqualified persons.
9. Where the US Army Corps of Engineers, the state, or surrogate thereof has issued a crossing permit, clearance of that permit shall govern.

Supersedes 1/06 Issue – Added FN 6, added switch handles in FN 7.

**7.9 CLEARANCE OF WIRES, CONDUCTORS, CABLES AND UNGUARDED LIVE PARTS TO BUILDINGS & OTHER INSTALLATIONS EXCEPT BRIDGES**

Primary wires should not be installed over buildings. There are cases, however, especially for temporary work, where such construction cannot be avoided. The clearance of 300 V to 15,000 volt lines over or near buildings and appurtenances shall be as much as is practicable. In no case should it be less than shown below. Services may however, be attached to or run along, or over the building in accordance with accepted practices.

Minimum clearances for multiplex conductors attached to buildings are shown below as well.

Supersedes 1/06 Issue – Editorial and paging revisions.

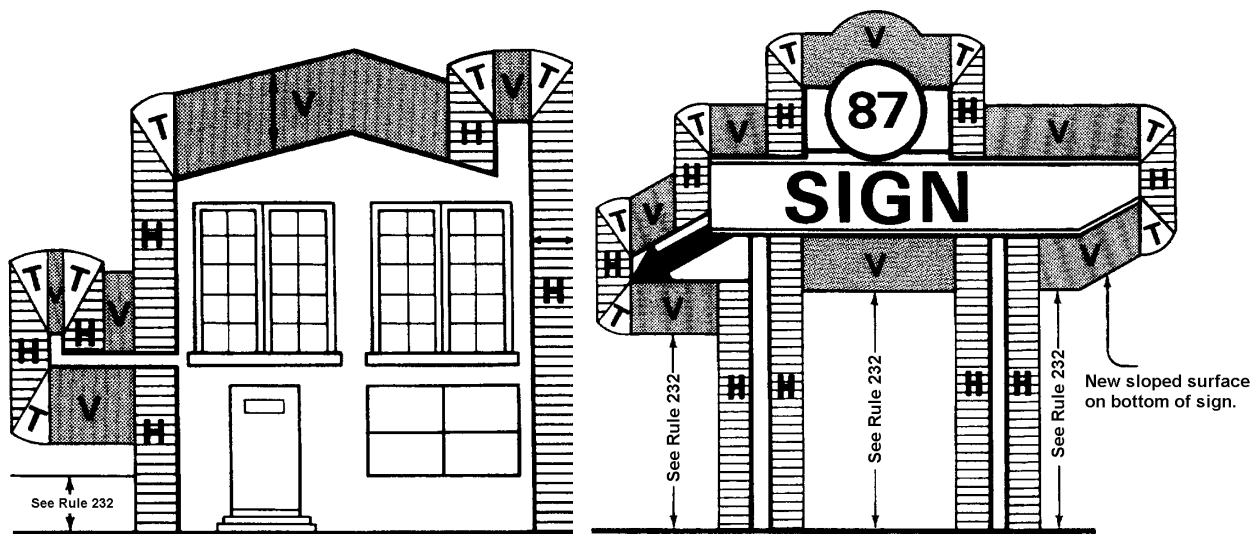

Figure 5

**Regions Where Conductors Are Prohibited:**  
**H = Horizontal; V = Vertical; T = Transitional = Vertical (Arc)**

**Table 6**  
**Clearance of Wires, Conductors, Cables and Unguarded Live Parts to**  
**Buildings & Other Installations Except Bridges**

(Reference: NESC Tables 234-1 and Rules 232 and 234)

Column	Section Heading
1	Grounded guys, messengers; surge protection wires; grounded neutrals; shielded supply cables supported by grounded messenger; ungrounded guys exposed to 0 to 300 V <sup>13</sup> ; and insulated communication cables and conductors
2	Non-shielded supply cables 0 to 750 V, supported by grounded messenger
3	Unguarded rigid live parts 0 to 750 V; ungrounded equipment cases, 0-750 V; ungrounded guys exposed to open supply conductors of over 300 to 750 V <sup>5</sup> , and non-insulated communication conductors
4	Open supply conductors 0-750 V; non-shielded supply cables supported by a grounded messenger, over 750 V and under 5 kV <sub>φ-φ</sub> or 2.9 kV <sub>φ-G</sub> <sup>18</sup>
5	Unguarded rigid live parts, over 750 V-22 kV; ungrounded equipment cases, 750 V-22 kV; ungrounded guys exposed to over 750 V to 22 kV <sup>5</sup>
6	Open supply conductors, over 750 V to 22 kV

Clearance of:	1	2	3	4	5	6
	(Feet)	(Feet)	(Feet)	(Feet)	(Feet)	(Feet)
1. Buildings						
a. Horizontal						
(1) To walls, projections, and guarded windows	4.5 <sup>2,7</sup>	5.0 <sup>2</sup>	5.0 <sup>2</sup>	5.5 <sup>2,9</sup>	7.0 <sup>2</sup>	7.5 <sup>2,10,11</sup>
(2) To unguarded windows <sup>8</sup>	4.5	5.0	5.0	5.5 <sup>9</sup>	7.0	7.5 <sup>10,11</sup>
(3) To balconies and areas readily accessible to pedestrians <sup>3</sup>	4.5	5.0	5.0	5.5 <sup>9</sup>	7.0	7.5 <sup>10,11</sup>
b. Vertical						
(1) Over/under roofs or projections not readily accessible to pedestrians	3.0	3.5	10.0	10.5	12.0	12.5
(2) Over/under balconies and roofs readily accessible to pedestrians <sup>3</sup>	10.5	11.0	11.0	11.5	13.0	13.5
(3) Over roofs accessible to vehicles but not subject to truck traffic <sup>6</sup>	10.5	11.0	11.0	11.5	13.0	13.5
(4) Over roofs accessible to truck traffic <sup>6</sup>	15.5	16.0	16.0	16.5	18.0	18.5
2. Signs, chimneys, billboards, radio and TV antennas, tanks, and other installations not classified as buildings or bridges						
a. Horizontal <sup>4</sup>						
(1) To portions that are readily accessible to pedestrians <sup>3</sup>	4.5	5.0	5.0 <sup>2</sup>	5.5 <sup>9</sup>	7.0 <sup>2</sup>	7.5 <sup>10,11</sup>
(2) To portions that are not readily accessible to pedestrians <sup>3</sup>	3.0	3.5	5.0 <sup>1,2</sup>	5.5 <sup>2,9</sup>	7.0 <sup>2</sup>	7.5 <sup>2,10,11</sup>
b. Vertical						
(1) Over/under catwalks and other surfaces upon which personnel walk	10.5	11.0	11.0	11.5	13.0	13.5
(2) Over/under other portions of such installations <sup>4</sup>	3.0	3.5	5.5	6.0	7.5	8.0
3. Clearance from other supporting structures <sup>15</sup>						
a. Horizontal (no wind)	5.0 <sup>16</sup>	5.0 <sup>16</sup>	5.0 <sup>16</sup>	5.0 <sup>16</sup>		5.0 <sup>16</sup>
b. Vertical	4.5 <sup>17</sup>	4.5 <sup>17</sup>	4.5 <sup>17</sup>	4.5 <sup>17</sup>		4.5 <sup>17</sup>

Supersedes 7/08 Issue – Deleted Footnote 1 and references to it to reflect 2017 NESC revisions.

**FOOTNOTES:**

- Footnotes 1 and 12 are not used
- 2. Where available space may not permit this value, the clearance may be reduced by 2 feet provided the wires, conductors, or cables, including splices and taps, and unguarded live parts have a covering that provides sufficient dielectric strength to limit the likelihood of a short circuit in case of momentary contact with a structure or building.
- 3. A roof, balcony, or area is considered readily accessible to pedestrians if it can be casually accessed through a doorway, ramp, window, stairway, or permanently mounted ladder by a person on foot who neither exerts extraordinary physical effort nor employs tools or devices to gain entry. A permanently mounted ladder is not considered a means of access if its bottom rung is 8 feet or more from the ground or other permanently installed accessible surface.

Supersedes 17/08 Issue – Revised FN7 to require guys to be effectively grounded, not just grounded, to allow reduced clearances.

4. The required clearances shall be to the closest approach of motorized signs or moving portions of installations (reference NESC rule 234C).
5. Ungrounded guys and ungrounded portion of guys between guy insulators shall have clearances based on the highest voltage to which they may be exposed to a slack conductor or guy.
6. For purpose of this rule, trucks are defined as any vehicle exceeding 8 feet in height.
7. This clearance may be reduced to 3 inches for the effectively grounded portions of guys. 
8. Windows not designed to open may have the clearances permitted for walls and projections.
9. The clearance at rest shall be not less than the value shown in this table. Also, when the conductor or cable is displaced by wind, the clearance shall be not less than 4.5 feet (reference NESC Rule 234C1b).
10. The clearance at rest shall be not less than the value shown in this table. Also, when the conductor or cable is displaced by wind, the clearance shall be not less than 4.5 feet (reference NESC Rule 234C1b).
11. Where available space will not permit this value, the clearance may be reduced to 7 feet for conductors limited to 8.7 kV to ground.
13. The anchor end of guys insulated in accordance with these standards may have the same clearance as grounded guys.
14. For clearances above railings, walls, or parapets around balconies or roofs, use the clearances required for roofs not accessible to pedestrians.
15. Support structures include those to which the conductor is not attached, such as lighting support, a traffic signal support, and a supporting structure of another line.
16. This may be reduced to 3 feet for effectively grounded guys and messengers, insulated communication conductors and cables, neutral conductors that are effectively ground throughout their length and associated with circuits of 0 to 22 kV phase to ground (i.e. meeting NESC Rule 230E1), and supply cables of 300 V or less that are insulated and cabled together with an effectively grounded bare messenger or neutral (i.e. meeting NESC Rule 230C1, 230C2 or 230C3).
17. This may be reduced to 2 feet for effectively grounded guys and messengers, insulated communication conductors and cables, neutral conductors that are effectively ground throughout their length and associated with circuits of 0 to 22 kV phase to ground (i.e. meeting NESC Rule 230E1), and supply cables of 300 V or less that are insulated and cabled together with an effectively grounded bare messenger or neutral (i.e. meeting NESC Rule 230C1, 230C2 or 230C3).
18. Does not include neutral conductors effectively ground throughout their length and associated with circuits of 0 to 22 kV phase to ground (i.e. meeting NESC Rule 230E1).

**Note:**

For horizontal clearances under wind displacement conditions, reference the table found in 7.10 corresponding to minimal clearance values. Sample calculations for accounting for wind displacement can be referenced on Page 7-124.

**7.10 CLEARANCE TO BRIDGES**

The clearance of distribution conductors and cables to bridges shall not be less than those shown in Table 7 below. These are minimum values that should be increased wherever practicable. The clearance over pedestrian walks or over roadways on bridges shall meet the requirements of Table 2 on Page 7-6.

For all spans, horizontal clearances must be increased as shown on Page 7-124.

Under wind displacement conditions, the following conductors and cables shall be in accordance with the below specified horizontal clearances to bridges. Sample calculations for increased clearances due to wind displacement can be referenced on Page 7-124.

**Table 7**  
**Horizontal Clearances Under Wind Displacement Conditions<sup>2</sup>**  
(Reference: NESC Rule 234D1b)

Conductor of Cable	Horizontal Clearance Required when Displaced by Wind
	(Feet)
Open Supply Conductor, 0 to 750 V <sup>1</sup>	3.5
230C2 Cable, Above 750 V	3.5
230C3 Cable, Above 750 V	3.5
Open Supply Conductor, over 750 V to 22 kV	4.5

**FOOTNOTES:**

1. Does not include neutral conductors effectively grounded throughout their length and associated with circuits of 0 to 22 kV phase to ground (i.e. meeting NESC Rule 230E1).
2. See Table 8 for clearances for conductors and cables at rest (not displaced by wind).

**Table 8**  
**Clearance of Wires, Conductors, Cables, and Unguarded Rigid Live Parts from Bridges**  
(Reference: NESC Table 234-2 and Rule 234D1a)

Column	Section Heading
1	Unguarded rigid live parts, 0 to 750 V; non-insulated communication conductors; supply cables of 0 to 750 V meeting Rules 230C2 or 230C3 <sup>7</sup> ; ungrounded equipment cases; 0 to 750 V; ungrounded guys exposed to open supply conductors over 300 V to 750 V <sup>4</sup>
2	Supply cables over 750 V meeting Rules 230C2 or 230C3 <sup>7</sup> ; open supply conductors, 0 to 750 V <sup>10</sup>
3	Open supply conductors, over 750 V to 22 kV
4	Unguarded rigid live parts, over 750 V to 22 kV; ungrounded equipment cases, 750 V to 22 kV; ungrounded guys exposed to open supply conductors of over 750 V to 22 kV <sup>4</sup>

	Column 1 (Feet)	Column 2 (Feet)	Column 3 (Feet)	Column 4 (Feet)
1. Clearance over bridges <sup>1</sup>				
a. Attached <sup>3</sup>	3.0	3.5	5.5	5.0
b. Not Attached	10.0	10.5	12.5	12.0
2. Clearance beside, under, or within bridge structure <sup>6</sup>				
a. Readily accessible portions of any bridge including wing, walls, and bridge attachments <sup>1</sup>				
(1) Attached <sup>3</sup>	3.0	3.5 <sup>8</sup>	5.5 <sup>9</sup>	5.0
(2) Not Attached	5.0	5.5 <sup>8</sup>	7.5 <sup>9</sup>	7.0
b. Ordinarily inaccessible portions of bridges (other than brick, concrete, or masonry) and from abutments <sup>2</sup>				
(1) Attached <sup>3,5</sup>	3.0	3.5 <sup>8</sup>	5.5 <sup>9</sup>	5.0
(2) Not Attached <sup>4,5</sup>	4.0	4.5 <sup>8</sup>	6.5 <sup>9</sup>	6.0

Supersedes 1/06 Issue – Added FNs 1 and 2.

**FOOTNOTES:**

1. Where over traveled ways on or near bridges, the clearances of Section 7.4 also apply.
2. Bridge seats of steel bridges carried on masonry, brick, or concrete abutments that require frequent access for inspection shall be considered as readily accessible portions.
3. Clearance from supply conductors to supporting arms and brackets attached to bridges shall be the same as specified in Section 7.14 if the supporting arms and brackets are owned, operated, or maintained by the same utility.
4. Ungrounded guys and ungrounded portions of guys between guy insulators shall have clearances based on the highest voltage to which they may be exposed due to a slack conductor or guy.
5. Where conductors passing under bridges are adequately guarded against contact by unauthorized persons and can be de-energized and appropriately grounded on each side of the work location for maintenance of the bridge, clearances of the conductors from the bridge, at any point, may have the clearances specified in Section 7.14 for clearance from surfaces of support arms plus one-half the final unloaded sag of the conductor at that point.
6. Where the bridge has moving parts, such as a lift bridge, the required clearances shall be maintained throughout the full range of movement of the bridge or any attachment thereto.
7. Where permitted by the bridge owner, supply cables may be run in rigid conduit attached directly to the bridge.
8. The clearance at rest shall not be less than the value shown in this Table. Also, when the conductor or cable is displaced by wind, the clearance shall be not less than 3.5 feet (reference NESC Rule 234D1b).
9. The clearance at rest shall be not less than the value shown in this Table. Also, when the conductor or cable is displaced by wind, the clearance shall be not less than 4.5 feet (reference NESC Rule 234D1b).
10. Does not include neutral conductors effectively grounded throughout their length and associated with circuits of 0 to 22 kV phase to ground (i.e. meeting NESC Rule 230E1).

Supersedes 7/08 Issue – Corrected page reference in 7.11.10.

**7.11 SEPARATION OF CONDUCTORS AND SUPPORTS ON THE SAME POLE**

**7.11.10 General**

Minimum recommended separations between supports and conductors on the same pole are shown in Table 9 on Page 7-20. These should be used on all poles for new lines. They shall generally be used for pole replacements. These should be used only when values recommended for new poles per the Drawings demonstrated in Section 9 - Primaries, are not practicable. As these values are suggesting minimum guidelines, clearances shall be increased to provide additional safety protection wherever possible.

**Table 9**  
**Vertical Clearance Between Conductors at Supports**  
**(Reference: NESC Rules 235A, C and Table 235-5)**

Column	Section Heading
1	Lashed aerial cables (insulated and fully metallic shielded) installed according to these standards and cabled together with an effectively grounded bare messenger or neutral (i.e. meeting NESC Rule 230C1); insulated, nonshielded cable operated at not over 5 kV phase to phase, or 2.9 kV phase to ground, supported on and cabled together with an effectively grounded bare messenger or neutral (i.e. meeting NESC Rule 230C3); neutral conductors that are effectively ground throughout their length and associated with circuits of 0 to 22 kV phase to ground (i.e. meeting NESC Rule 230E1); and insulated communication cables, located in the supply space, supported by an effectively grounded messenger (i.e. meeting NESC Rule 224A2)
2	Open supply conductors, 0 to 8.7 kV <sup>12</sup>
3	Open supply conductors, over 8.7 kV to 50 kV, same utility <sup>8</sup>
4	Open supply conductors, over 8.7 kV to 50 kV, different utilities <sup>8</sup>

Conductors and Cables Usually at Lower Levels	Conductors and Cables Usually At Upper Levels							
	Column 1		Column 2 <sup>12</sup>		Column 3 <sup>8</sup>		Column 4 <sup>8</sup>	
	(Inches)		(Inches)		(Inches)		(Inches)	
	At Pole	Mid-Span	At Pole	Mid-Span	At Pole	Mid-Span	At Pole	Mid-Span
1. Communication Conductors and Cables								
a. Located in the communication space	40 <sup>1,5,6</sup>	30 <sup>12</sup>	40	30 <sup>13</sup>	40	30	40+A <sup>7</sup>	See Note 15
b. Located in the supply space	16 <sup>9,10</sup>	12	16 <sup>10</sup>	12	40 <sup>10</sup>	30	40+A <sup>7</sup>	See Note 15
2. Supply conductors and cables								
a. Open conductors 0 to 750 V; lashed aerial cables (insulated and fully metallic shielded) installed according to these standards and cabled together with an effectively grounded bare messenger or neutral; insulated, nonshielded cable operated at not over 5 kV phase to phase, or 2.9 kV phase to ground, supported on and cabled together with an effectively grounded bare messenger or neutral; and neutral conductors that are effectively ground throughout their length and associated with circuits of 0 to 22 kV phase to ground (i.e. meeting NESC Rule 230E1)	16 <sup>9</sup>	12	16 <sup>2</sup>	12 <sup>14</sup>	16+A <sup>4,7</sup>	See Note 15	40+A <sup>7</sup>	See Note 15
b. Open conductors over 750 V to 8.7 kV			16 <sup>2</sup>	12	16+A <sup>4,7</sup>	See Note 15	40+A <sup>7</sup>	See Note 15
c. Open conductors over 8.7 to 22 kV					16+A <sup>7</sup>	See Note 15	40+A <sup>7</sup>	See Note 15
(1) If worked on alive with live-line tools and adjacent circuits are neither de-energized nor covered with shields or protectors					16+A <sup>3,7</sup>	See Note 15	40+A <sup>3,7</sup>	See Note 15
(2) If not worked on alive except when adjacent circuits (either above or below) are de-energized or covered by shields or protectors, or by use of live-line tools not requiring line workers to go between live wires					16+A <sup>3,7</sup>	See Note 15	40+A <sup>3,7</sup>	See Note 15
d. Open conductors exceeding 22 kV , but not exceeding 50 kV					16+A <sup>3,7</sup>	See Note 15	40+A <sup>3,7</sup>	See Note 15

A = 0.4 inches per kV in excess of 8.7 kV

When using column and row headings, voltages are phase to ground for effectively grounded circuits and those other circuits where all ground faults are cleared by promptly de-energizing the faulted section, both initially and following subsequent breaker operations.

Supersedes 7/08 Issue – Added new FN 6 & renumbered FNs 6 & 7.

**FOOTNOTES:**

1. Where supply circuits of 600 V or less, with transmitted power of 5,000 W or less, are run below communication circuits, the clearance may be reduced to 16 inches. This type of installation must be built following special requirements of NESC Rule 220B2. Distribution Standards Engineering should be consulted prior to making an installation of this type.
2. Where conductors are operated by different utilities, a vertical clearance of not less than 40 inches is recommended.
3. These values do not apply to conductors of the same circuit or circuits being carried on adjacent conductor supports.
4. May be reduced to 16 inches where conductors are not worked on live except when adjacent circuits (either above or below) are de-energized or covered by shields or protectors, or by the use of live line tools not requiring line workers to go between live wires.
5. May be reduced to 30 inches for neutral conductors effectively grounded throughout their length and associated with circuits of 0 to 22 kV phase to ground (i.e. meeting NESC Rule 230E1); fiber-optic cables installed in the supply space supported on a messenger that is effectively grounded throughout its length (i.e. meeting NESC Rule 230F1a); and entirely dielectric fiber-optic cables or fiber-optic cables supported on a messenger that is entirely dielectric and installed in the supply space (i.e. meeting NESC Rule 230F1b). Bonding is not required for entirely dielectric fiber-optic cables or fiber-optic cables supported on a messenger that is entirely dielectric and installed in the supply space (i.e. meeting NESC Rule 230F1b).
6. May be reduced to 30 inches for lashed aerial cables that are insulated, shielded and installed according to these standards where the supply neutral or messenger is bonded to the communication messenger (i.e. meeting NESC Rule 230C1), except that in accordance with the PPL settlement agreement with Verizon, Verizon requires PPL to maintain 40" clearance at the pole between lashed aerial cables and Verizon owned communication cables. Application of this exception for lashed aerial cables shall require approval from Overhead Distribution Standards.
7. The greater of phasor difference or phase-to-ground voltage (for more information see NESC Rule 235A3).
8. Example: For a 50 kV-to-ground conductor above a 22 kV-to-ground conductor, when the conductors are 180 degrees out of phase:  $A = ( 50 + 22 - 8.7 ) * 0.4 = 25.4$  inches, then round A up to 26 inches.
9. No clearance is specified between neutral conductors effectively grounded throughout their length and associated with circuits of 0 to 22 kV phase to ground (i.e. meeting NESC Rule 230E1) and insulated communication cables located in the supply space and supported by an effectively grounded messenger (i.e. meeting NESC Rule 230F1a).
10. No clearance is specified between entirely dielectric fiber-optic cables or fiber-optic cables supported on a messenger that is entirely dielectric and installed in the supply space (i.e. meeting NESC Rule 230F1a) and supply cables and conductors.
11. Does not include neutral conductors effectively ground throughout their length and associated with circuits of 0 to 22 kV phase to ground.

Supersedes 7/08 Issue – Revised FN 5, added new FN 6 & renumbered FNs 6 & 7.

12. May be reduced to 12 inches for neutral conductors effectively grounded throughout their length and associated with circuits of 0 to 22 kV phase to ground (i.e. meeting NESC Rule 230E1); fiber-optic cables installed in the supply space supported on a messenger that is effectively grounded throughout its length (i.e. meeting NESC Rule 230F1a); entirely dielectric fiber-optic cables or fiber-optic cables supported on a messenger that is entirely dielectric and installed in the supply space (i.e. meeting NESC Rule 230F1b); and lashed aerial cables installed according to these standards where the supply neutral or messenger is bonded to the communication messenger (i.e. meeting NESC Rule 230C1). Bonding is not required for entirely dielectric fiber-optic cables or fiber-optic cables supported on a messenger that is entirely dielectric and installed in the supply space (i.e. meeting NESC Rule 230F1b).
13. Supply service drops of 0 to 750 volts, running above and parallel to communication service drops, may have a spacing of not less than 12 inches at any point in the span, including the point of their attachment to the building or structure being served provided the non-grounded conductors are insulated and that clearance as otherwise required by these standards is maintained between the two service drops at the pole.
14. Where conductors are operated by different utilities, a vertical clearance of not less than 30 inches is recommended.
15. 75% of clearance required at the pole.

**7.11.20 Separation on Replaced Poles**

In general, the separations on poles that are replaced shall conform to the requirements for new poles. In some special cases, separation may be reduced, but shall not be less than permitted on existing poles.

**7.11.30 Reduction of Separation on Poles**

Reduced separations of conductors and facilities may be used to accommodate other pole users but shall not be less than clearances required for 15 kV primary circuits.

**7.11.40 Basic Impulse Level (BIL) & Air – Wood Spacing**

BIL refers to the ability of the pole top design to resist flashovers caused by lightning or line surges.

Distribution pole tops are generally designed to provide 150 kV minimum BIL. This impulse strength shall be based entirely on the impulse flashover of 20 inches or more of wood. Where lightning arresters are used, the “inches of wood” requirement does not apply for the particular conductor having the arrester. In locations where sufficient wood separation is not obtainable due to guy attachment, the use of a fiberglass guy strain insulator will meet this requirement. Additionally, insulated pole top pins (P6B and P6C), long strain insulators (I2), guy strain insulator (TI95B, TI95C, TI95D), and wood braces (TB60 & B37B) may be used to provide the necessary separation if it cannot be met with standard hardware.

In design and construction of pole tops, avoid shorting out the insulation provided by air and wood with steel crossarm braces, steel hardware, ground wires, guy wires, etc. The total distance measured over insulators, wood, and air should be as great as possible.

Supersedes 7/08 Issue – Paging revisions.

**7.11.50 Climbing Space**

Standard pole top designs shall meet or exceed code requirements for vertical or lateral clearance for line conductors at different levels attached to the same pole. When various designs are combined, however, or when work is done on an existing pole, care should be taken to provide good clearance and to maintain climbing and working space. Page 7-127 shows the NESC clearance required when workers must climb through energized conductors. This drawing should be used as a guide even when the conductors concerned are covered by protective equipment or otherwise guarded as an unvarying practice before personnel climb past them.

Those who install services and secondaries should provide enough space for the personnel who may have to climb through these services to work on the primaries above. Multiplex service taps made 3 feet or more away from the pole will help improve the climbing and working space (Reference Section 10-Secondaries, Construction Drawings).

The climbing space needs to be provided on one side or a corner of the support only.

Vertical runs physically protected by conduit or other protective covering securely attached without spacers to the surface of the pole are not considered to obstruct climbing space.

The climbing space shall extend vertically in the same position - 40 inches above and 40 inches below any wire attachment, but may otherwise be shifted to any other adjacent side or corner of the pole.

All voltages in Table 10 on Page 7-22 are between the two conductors bounding the climbing space, except for communications conductors, which are voltage to ground. Where two conductors are in different circuits, the voltage between conductors shall be the arithmetic sum of the voltages of each conductor to ground for a grounded circuit or phase to phase for an ungrounded circuit.

Supersedes 7/08 Issue – Paging revisions.

**Table 10**  
**Horizontal Climbing Space Between Conductors**  
**(Reference: NESC Rule 236 and Table 236-1)**

Character of Conductors Adjacent to Climbing Space	Voltage of Conductors	Horizontal Clearance Between Conductors Bounding the Climbing Space <sup>2</sup>			
		On S.O. Structures used Solely By:		On J.O. Structures	
		Communication Conductors (Inches)	Supply Conductors (Inches)	Supply Conductors Above Communications Conductors (Inches)	Communication Conductors Above Supply Conductors <sup>3</sup> (Inches)
1. Communication conductors	0 to 150 V	No Requirements	--	See Footnote 1	No Requirements
	Over 150 V	24 Recommended	--	See Footnote 1	24 Recommended
2. Lashed aerial cables (insulated and shielded) installed according to these standards (i.e. meeting NESC Rule 230C1)	All	--	--	See Footnote 1	No Requirements
3. Insulated, nonshielded cable operated at not over 5 kV phase to phase, or 2.9 kV phase to ground, supported on and cabled together with an effectively grounded bare messenger or neutral (i.e. meeting NESC Rule 230C3).	All	--	24	24	30
4. Open supply line conductors and covered supply cables, including spacer cable and tree wire (i.e. meeting NESC Rule 230D)	0-750 V	--	24	24	30
	750 V-15 kV	--	30	30	30
	15 kV-28 kV	--	36	36	36
	28 kV-38 kV	--	40	40	
	38 kV-50 kV	--	46	46	
	50 kV-73 kV	--	54	54	
Over 73 kV	--	--	>54		

Supersedes 7/08 Issue – Paging revisions.

**FOOTNOTES:**

1. Climbing space shall be the same as required for the supply conductors immediately above, with a maximum of 30 inches except that a climbing space of 16 inches across the line may be used for communication cables or conductors where the only supply conductors at a higher level are 0 to 750 V secondaries supplying airport or airway marker lights or crossing over the communication line and attached to the pole top or a pole-top extension fixture.
2. Attention is called to the operating requirements of NESC Rules 441A and 446C.
3. This relation of levels in general is not desirable and should be avoided.
4. The climbing space specified in Table 10 above shall be provided above the top support arm to the ridge pin conductor but need not be carried past it.
5. All supply equipment such as transformers, capacitors, cable terminations, switches, etc. when located below conductors or other attachments, shall be mounted outside the climbing space.

**7.12 CLEARANCE TO PROPERTY LINE**

In general, conductors and supports shall not overhang property lines unless a right of way or easement has been obtained. In checking overhang, it should be assumed that conductors on rigid supports will be deflected by wind at the amount calculated on Page 7-124.

Plan for future buildings or structures along the property lines, or, if local ordinances specify, along the established building line. If it is probable that a structure will be erected in the foreseeable future, the right-of-way should be adequate to provide standard clearances to such a structure.

**7.13 VERTICAL CLEARANCE BETWEEN WIRES, CONDUCTORS & CABLES AT POINT OF CROSSING DIFFERENT SUPPORTING STRUCTURES**

It is generally undesirable to build a distribution line directly over or under another line. Where this cannot be avoided, clearance should be provided so that a worker on the top of a pole will be able to maintain adequate working clearances from conductors overhead. Six feet of clearance from the pole top to overhead distribution conductors at 60°F/15°C final sag is suggested as a minimum. See Sub-Transmission or Transmission Standards for voltages over 22 kV.

**Table 11  
Vertical Clearance Between Wires, Conductors, and Cables Carried on Different Supporting Structures  
(Reference: NESC Rule 233, Table 233-1)**

Column	Section Heading
1	Effectively grounded supply guys, <sup>7</sup> span wires and messengers, neutral conductors effectively grounded throughout their length and associated with circuits of 0 to 22 kV phase to ground (i.e. meeting NESC Rule 230E1), and overhead shield/surge-protection wires
2	Effectively grounded communication guys, <sup>7</sup> span wires and communication conductors and cables
3	Lashed aerial cables (insulated and shielded) installed according to these standards (i.e. meeting NESC Rule 230C1), and insulated supply cables of 0 to 750 V (i.e. meeting NESC Rule 230C2 or 230C3)
4	Open supply conductors 0 to 750 V, <sup>6</sup> and insulated supply cables over 750 V other than lashed aerial cables (i.e. meeting NESC Rule 230C2 or 230C3)
5	Open supply conductors over 750 V to 22 kV

Supersedes 7/08 Issue – Paging revisions.

Lower Level	Upper Level				
	1 (ft)	2 (ft)	3 (ft)	4 (ft)	5 (ft)
1. Effectively grounded supply guys, <sup>7</sup> span wires and messengers, neutral conductors effectively grounded throughout their length and associated with circuits of 0 to 22 kV phase to ground, and overhead shield/surge-protection wires	2 <sup>1,2</sup>	2 <sup>1,2</sup>	2 <sup>2</sup>	2	2
2. Effectively grounded communication guys, <sup>7</sup> span wires and communication conductors and cables	2 <sup>1</sup>	2 <sup>1,2</sup>	2	4 <sup>8</sup>	5 <sup>7</sup>
3. Lashed aerial cables (insulated and shielded) installed according to these standards, and insulated supply cables of 0 to 750 V	2	2	2	2	2
4. Open supply conductors 0 to 750 V, <sup>6</sup> and insulated supply cables over 750 V other than lashed aerial cables	2	4 <sup>9</sup>	2	2	2
5. Open supply conductors, 750 V to 22 kV	2	5 <sup>5,9</sup>	2 <sup>9</sup>	2 <sup>9</sup>	2

**FOOTNOTES:**

**Note:** Footnotes 3, 4, 6, are not used.

1. No clearance is specified between guys or span wires that are electrically interconnected.
2. The clearance of communication conductors and their guy span, and messenger wires from each other in locations where no other classes of conductors are involved may be reduced by mutual consent of the parties concerned, subject to the approval of the regulatory body having jurisdiction, except for fire-alarm conductors and conductors used in the operation of railroads.
5. This clearance may be reduced to 4 feet where supply conductors of 750 V to 8.7 kV cross a communication line more than 6 feet horizontally from the communications structure.
6. Does not include neutral conductors effectively grounded throughout their length and associated with circuits of 0 to 22 kV phase to ground (i.e. meeting NESC Rule 230E1).
7. These clearances may be reduced by not more than 25% to a guy insulator, provided that full clearance is maintained to its metallic end fittings and the guy wires. The clearance to an insulated section of a guy between two insulators may be reduced by not more than 25% provided that full clearance is maintained to the uninsulated portion of the guy.
8. This clearance may be reduced to 2 feet for supply service drops.
9. In general, this type of crossing is not recommended.

**7.14 CLEARANCES OF VERTICAL & LATERAL SUPPLY CONDUCTORS FROM OTHER WIRES & SURFACES OF THE SAME STRUCTURE**

**Table 12<sup>1</sup>**  
**Clearance of Open Lateral<sup>2</sup> and Vertical Conductors (Inches)**  
(Reference: NESC Rule 239E, Tables 239-1)

Clearances of Open Vertical & Lateral Conductors	Phase to Phase Voltage				
	0-8.7 kV (Inches)	8.7-15 kV (Inches)	15-25 kV (Inches)	25-35 kV (Inches)	35-50 kV (Inches)
From Surfaces of Supports	3 <sup>3</sup>	5	7	9	12
From Span Guys and Messenger Wires <sup>6</sup>	6 <sup>4</sup>	9	13	17	23
Anchor Guys	6	8	11	13	17

**Table 13<sup>5</sup>**  
**Clearances Between Open Vertical Conductors and Pole Surface (Figures 6 & 7)**  
(Reference: NESC Rule 239E, Tables 239-2)

Clearances of Open Vertical & Lateral Conductors	Effectively Grounded Circuits (Φ-G) Voltage	Not Effectively Grounded Circuits (Φ-Φ) Voltage	A. Zones Above & Below Conductor Where Clearances May Apply	B. Minimum Clearance Between Vertical Conductor & Pole Center
	(kV)	(kV)	(Feet)	(Inches)
From Surfaces of Supports	0 to 22	0 to 22	6	19
From Span, Guy and Messenger Wires <sup>6</sup>	22 to 30	22 to 30	6	22
Anchor Guys	30 to 50	30 to 50	6	30

Supersedes 7/08 Issue – Paging revisions.

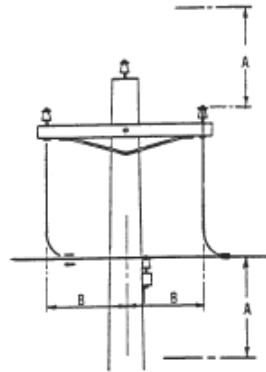

**Figure 6**

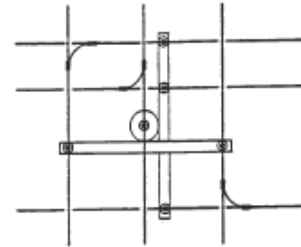

**Figure 7**

***A = zone above and below conductor***  
***B = distance between vertical wire and pole center***

**FOOTNOTES:**

1. Table 12 applies to supply conductors on supply line structures or within the supply space of jointly used poles.
2. Lateral - A wire or cable extending in a general horizontal direction at an angle to the general direction of the line conductors.
3. Clearance may be reduced to 1 inch for supply circuits 0 to 750 volts. A neutral conductor may be attached directly to the structure surface.
4. Clearance may be reduced to 2 inches for insulated non-shielded cable operated at 0 to 750 volts and supported on and cabled together with an effectively grounded bare messenger.
5. If open wire conductors are within 4 feet of the pole, vertical conductors shall be run in one of the following ways:
  - a. Open vertical conductors shall have the clearances given in Table 13 within the zone specified in the table.
  - b. Within the zone above and below open supply conductors, as given in Table 13, vertical and lateral conductors may be enclosed in nonmetallic conduit or in cable protected by an insulated covering and may be run on the pole surface.
  - c. Grounding conductors may be run on the pole surface without molding.
6. These clearances may be reduced by not more than 25% to a guy insulator, provided that full clearance is maintained to its metallic end fittings and the guy wires. The clearance to an insulated section of a guy between two insulators may be reduced by not more than 25% provided that full clearance is maintained to the uninsulated portion of the guy.

Supersedes 7/08 Issue – Paging revisions.

Basic HORIZONTAL clearances shown in Tables 2, 4, 6, 7, 8, and 11 must be increased as follows to allow for wind caused lateral conductor displacement. For horizontal adders between conductors carried on different poles (Table 11), apply adder for only one of the conductors.

The vertical sag at 60°F/15°C final with 6 lb. wind taken from Section 6-Primary Conductors for the subject conductor and span is multiplied by the sine of the conductor's swing angle to obtain maximum conductor horizontal movement.

The sine of the swing angle may be calculated or taken from the following table (rounding up to the next value shown).

Swing Angle (Θ)	Sine
25°	0.4226
30°	0.5000
35°	0.5736
40°	0.6428
45°	0.7071
50°	0.7660
55°	0.8192
60°	0.8660

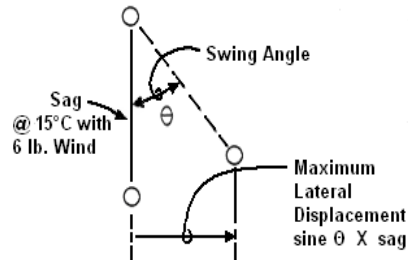

**Example:**

For a 200 feet span of 336.4 kcm AAC 19 Strand Bare (Std. Item W20B)



1. Swing Angle = 46.5degrees (from Page 6-121)
2. Multiplier = 0.7660 (from table above for 50°)
3. Sag at 60°F/15°C, 6 lb. wind for 200 foot span = 48.36 inches (from Page 6-122)
4. Maximum Lateral Displacement = (48.36 inches) X (0.7660) = 37.04 inches

**Note:**

If point of conflict is not at point of maximum sag, the additional horizontal clearance may be reduced as follows:

If the distance between point of crossing or clearance and the nearest support is \_\_\_% of the total span, multiply additional clearance by the multiplier outlined below.

Percent of Span	Multiplier
5%	0.19
10%	0.36
15%	0.51
20%	0.64
25%	0.75
30%	0.84
35%	0.91
40%	0.96
45%	0.99
50%	1.00
*Interpolate for intermediate vales or use next higher multiplier.	

Supersedes 1/06 Issue – Corrected conductor information page references.

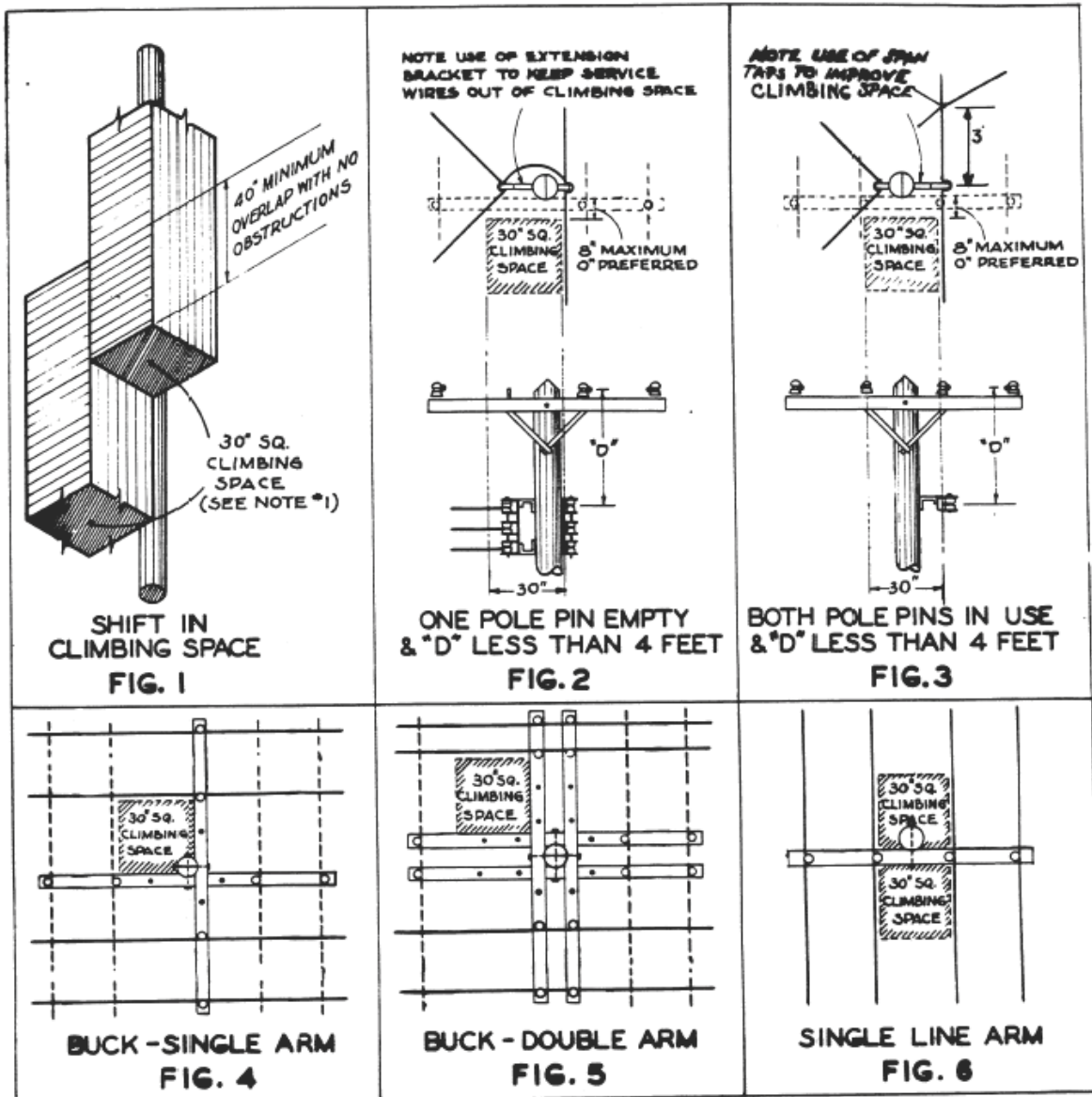

**Notes:**

1. The climbing space should preferably be continuous from the ground to beyond the top of the pole; but when necessary, it may be shifted from one quarter of the pole to another provided the sections overlap at least 40 inches and there are no obstructions between the two climbing space columns. The climbing space column should extend 40 inches above and below the limiting conductors, but need not extend above a pole top pin.
2. Climbing space should be located in the quarter of the pole not occupied by risers.

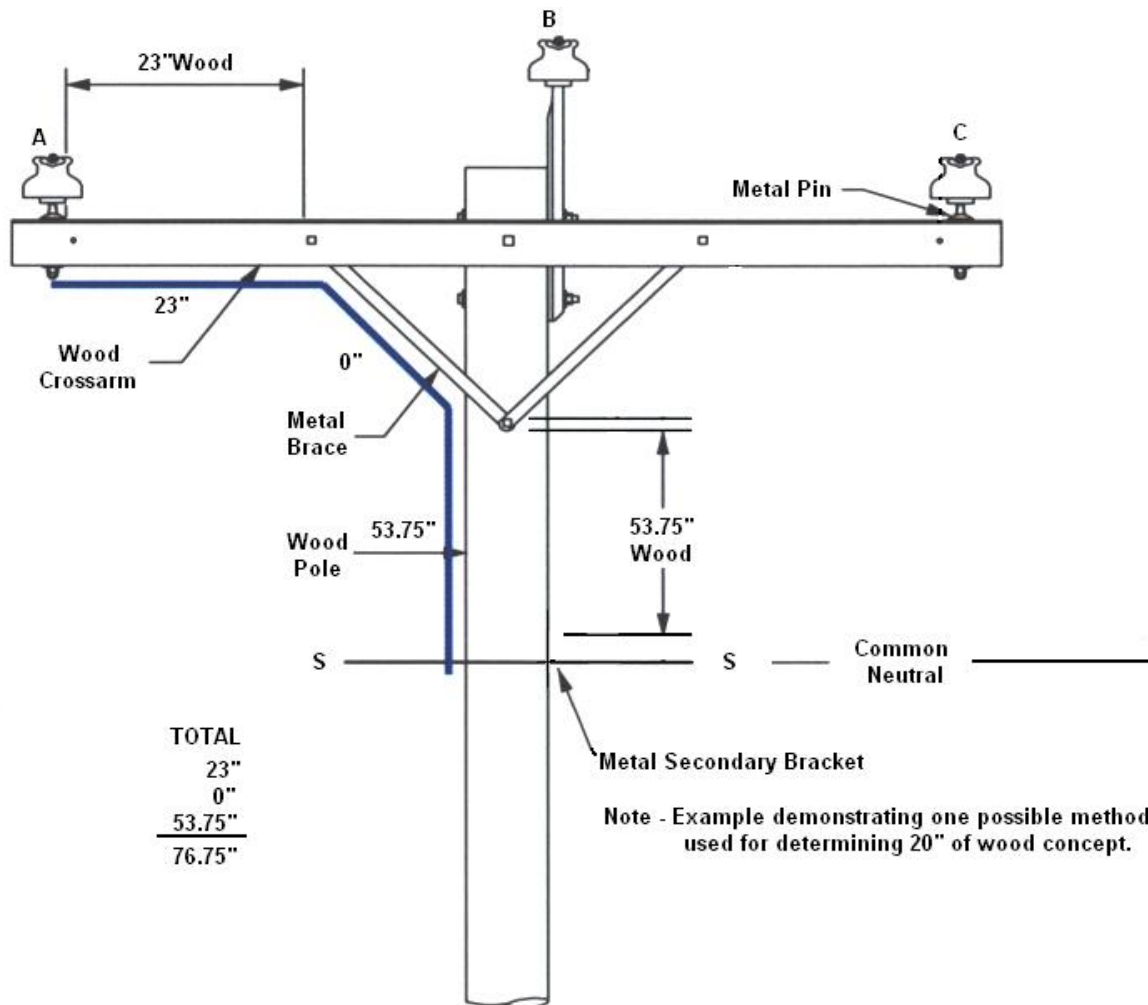

To resist current leakage or electrical flashover a minimum amount of 20" of wood and effective insulation is needed. Non-conducting material such as air, wood, porcelain, or fiberglass is taken together to determine the insulation level.

Keep as much air, wood, porcelain and fiberglass between phase and ground and between phases as is practicable. The above drawing illustrates the 20 inches of wood concept.

Spacing can be increased by :

1. Relocating hardware, pins, deadends, guy attachments, etc.
2. Using wood braces.
3. Using fiberglass pole top pin.
4. Using fiberglass guy insulator or extra insulators in deadends.

For applications where surge arresters are used, this 20 inches of wood requirement does not apply for the particular conductor having the arrester.

Version	Date	Modification	Author(s)	Approval by (Name/Title)
8	07/19	<ul style="list-style-type: none"> <li>Added information about required clearances within state highway rights-of-way in new Section 7.4 on page 7-6.</li> </ul>		
7	07/18	<ul style="list-style-type: none"> <li>Corrected page reference in Section 7.11.10 on page 7-19.</li> <li>Corrected conductor information page references on page 7-124.</li> </ul>		
6	07/17	<ul style="list-style-type: none"> <li>Added "effectively" to "grounded guys" when allowing reduced clearances to guy wires – Table 6, FN7, page 7-17.</li> </ul>		
5	07/16	<ul style="list-style-type: none"> <li>Page 7-8 – revise Footnotes 7 and 8 to reflect 2017 NESC revisions.</li> <li>Page 7-16 – delete Footnote 1 to reflect 2017 NESC revisions.</li> </ul>		
4	07/15	<ul style="list-style-type: none"> <li>Remove reference to nonexistent EOP from 7.0.30.</li> </ul>		
3	07/13	<ul style="list-style-type: none"> <li>Section 7.6 - Clearances to Swimming Pools: Revised text, modified FN 7 and added FN 8.</li> </ul>		
2	07/10	<ul style="list-style-type: none"> <li>Table 9: Revised FN 5, added new FN 6 and renumbered FNs 6 and 7 for Verizon clearances to PLAC at pole, per Verizon settlement agreement.</li> </ul>		
1	07/08	<ul style="list-style-type: none"> <li>Under 7.0.10, modified description of role of NESC &amp; standard.</li> <li>Under 7.11.10, modified description of MCOT.</li> <li>Under 7.11.10.R, fiber-optic cable information updated</li> <li>Clarified conductor type descriptions on page 7-8.</li> <li>Modified wire type descriptions and added water slides in Table 4.</li> <li>Added FN 6, added switch handles in FN 7 on page 7-14.</li> <li>Revised FNs 16 through 18 on page 7-17.</li> <li>Added FNs 1 and 2 under Table 7.</li> <li>Added FN 10 under Table 8.</li> <li>Modified column descriptions in Table 9.</li> <li>Revised FNs 1, 5, 7, 9, 10, 11 and 12 under Table 9.</li> <li>Revised Conductor Descriptions for Rows in Table 10.</li> <li>Modified conductor descriptions in Table 11.</li> <li>Added FN 6 under Table 11.</li> </ul>		

SECTION	PAGE
• 6.0 GENERAL	6-1
• 6.1 BASIC DATA	6-1 THRU 6-2
• 6.2 SAGS AND TENSIONS	6-2 THRU 6-5
• 6.3 MAXIMUM SPANS	6-5
• 6.4 AMPACITY	6-5 THRU 6-6
• 6.5 PLANNING CONDUCTOR INSTALATIONS	6-6 THRU 6-7
• 6.6 INSTALLING CONDUCTORS	6-7 THRU 6-8
• CONSTRUCTION DRAWINGS	
• STANDARD CONDUCTORS	6-100
○ 1113.0 kcmil, 54/19 Stranding, Bare ACSR, "FINCH" – 35kV	6-101 THRU 6-102
○ 795.0 kcmil, 54/7 Stranding, Bare ACSR, "CONDOR" – 35kV	6-103 THRU 6-104
○ 795.0 kcmil, 37 Strand, Bare AAC, "ARBUTUS" – 15kV	6-105 THRU 6-106
○ 795.0 kcmil, 19 Strand, Compact AAC, 320 mil Covered Tree Wire – 35 kV	6-107 THRU 6-108
○ 795.0 kcmil, 19 Strand, Compact AAC, 180 Mil Covered Tree Wire – 15 kV	6-109 THRU 6-110
○ 477.0 kcmil, 26/7 Stranding, Bare ACSR, "HAWK" – 15kV	6-111 THRU 6-112
○ 477.0 kcmil, 19 Strand, Bare AAC, "COSMOS" – 15kV	6-113 THRU 6-114
○ 477.0 kcmil, 19 Strand, Compact AAC, 320 mil Covered Tree Wire – 35 kV	6-115 THRU 6-116
○ 477.0 kcmil, 19 Strand, Compact AAC, 160 mil Covered Tree Wire – 15 kV	6-117 THRU 6-118
○ 336.4 kcmil, 18/1 Stranding, Bare ACSR, "MERLIN" – 15kV	6-119 THRU 6-120
○ 336.4 kcmil, 19 Strand, Bare AAC, "TULIP" – 15kV	6-121 THRU 6-122
○ 336.4 kcmil, 19 Strand, Compact AAC, 165 mil Covered Tree Wire– 15kV	6-123 THRU 6-124
○ 1/0, 7 Strand, Bare 6201-T81 AAAC, "AZUSA" – 15kV	6-125 THRU 6-126
○ 1/0, 7 Strand, Concentric Round 6201-T81 AAAC, 315 mil Covered Tree Wire – 35kV	6-127 THRU 6-128
○ 1/0, 7 Strand, Concentric Round 6201-T81 AAAC, 165 mil Covered Tree Wire – 15kV	6-129 THRU 6-130
• NON-STANDARD CONDUCTORS	6-200
○ 636.0 kcmil, 37 Strand, Bare AAC, "ORCHID"	6-201
○ 636.0 kcmil, 37 Strand, AAC, 95 Mil HDPE Covering, "TANGERINE"	6-202
○ 336.4 kcmil, 19 Strand, AAC, 170 mil HDPE Covering, "ANONA"	6-203
○ 336.4 kcmil, 19 Strand, AAC, 80 mil HDPE Covering, "CRABAPPLE"	6-204
○ 336.4 kcmil, 19 Strand, AAC, 60 mil PE Covering, "ANONA"	6-205
○ 4/0, 6/1 Stranding, Bare ACSR, "PENGUIN"	6-206
○ 4/0, 7 Strand, Bare AAAC, "ALLIANCE"	6-207
○ 4/0, 7 Strand, Bare AAC, "OXLIP"	6-208
○ 4/0, 7 Strand, AAC, 60 Mil PE Covering, "OLIVE"	6-209
○ 4/0, 7 Strand, AAAC, 60 Mil PE Covering, "PLANETREE"	6-210

PRIMARY CONDUCTORS INDEX			
	OVERHEAD CONSTRUCTION STANDARD	PAGE NUMBER	ISSUE
		6-i	4/25

SECTION	PAGE
○ 4/0, 19 Strand, AAC, 60 Mil PE Covering, "POMENGRANITE"	6-211
○ 1/0, 6/1 Stranding, Bare ACSR, "RAVEN"	6-212
○ 1/0, 6/1 Stranding, ACSR, 110 Mil PE Covering, "ALMOND"	6-213
○ 1/0, 6/1 Stranding, ACSR, 60 Mil PE Covering, "ALMOND"	6-214
○ 1/0, 7 Strand, AAAC, 60 Mil XLPE Covering, "OILNUT" – 15kV	6-215
○ #2, 6/1 Stranding, Bare ACSR, "SPARROW"	6-216
○ #2, 6/1 Stranding, ACSR, 45 Mil PE Covering, "PIGNUT"	6-217
○ #4, 7/1 Stranding, Bare ACSR, "SWANATE"	6-218
○ #4, 7/1 Stranding, ACSR, 30 Mil PE Covering, "HICKORY"	6-219
○ #4, 6/1 Stranding, ACSR, 30 Mil PE Covering, "BUTTERNUT"	6-220
• NON-STANDARD COPPER CONDUCTORS	6-300
○ 4/0, 7 Strand, Hard Drawn Copper, Bare	6-301
○ 1/0, 7 Strand, Hard Drawn Copper, Bare	6-302
○ 1/0, 7 Strand, Hard Drawn Copper, 60 Mil PE Covering	6-303
○ #2, 3 Strand, Type A Copper – Copperweld, Bare	6-304
○ #2, 7 Strand, Hard Drawn Copper, Bare	6-305
○ #2, 7 Strand, Soft Drawn Copper, 45 Mil PE Covering	6-306
○ #3, 7 Strand, Hard Drawn Copper, Bare	6-307
○ #3, 7 Strand, Hard Drawn Copper, 45 Mil PE Covering	6-308
○ #4, 3 Strand, Type A Copper – Copperweld, Bare	6-309
○ #4, Solid, Hard Drawn Copper, Bare	6-310
○ #4, Solid, Hard Drawn Copper, 30 Mil PE Covering	6-311
○ #6, 3 Strand, Type A Copper – Copperweld, Bare	6-312
○ #6, Solid, Hard Drawn Copper, Bare	6-313
○ #6, Solid, Hard Drawn Copper, 30 mil PE Covering	6-314

PRIMARY CONDUCTORS INDEX			
ISSUE	PAGE NUMBER	OVERHEAD CONSTRUCTION STANDARD	
	6-ii		

**6.0 GENERAL**

This Section covers the physical and electrical data on standard primary conductors and those that have been commonly used on overhead distribution systems.

Detailed design data for primaries, aerial and spacer cable, street lighting, and other specific conductor applications are covered in their respective sections of the text.

<u>Scenario</u>	<u>Bare</u>	<u>Tree Wire</u>	<u>Spacer Cable</u>	<u>Underground</u>
Open Field	Y	N	Y	Y
Heavily treed locations	N	N	Y	Y
High Fault current sections	N	N	Y	Y
Reduced Tension Spans	N	Y	N	N/A
Multi-Circuit	Y	Y	Preferred	Y
Close Spaced Construction	N	Y	N/A	N/A

**6.1 BASIC DATA**

Basic conductor data is shown on drawings and tables indicated in the index. This data may differ in minor detail from those shown in other handbooks. The information shown here, however, should be used for all Company records and correspondence unless otherwise approved. If there are any questions concerning accuracy, please consult Standards Engineering.

**6.1.10 Definitions & Notes:**

- PE = Regular Polyethylene Covering
- AAC = All Aluminum Conductor (Type ECA or EC)
- AAAC = All Aluminum Alloy Conductor, 5005 or 6201 aluminum alloy  
1/0 AAAC (123.3 kcmil) is the electrical equivalent of 1/0 ECA  
4/0 AAAC (246.9 kcmil) is the electrical equivalent of 4/0 ECA  
394.5 kcmil AAAC is the electrical equivalent of 336.4 kcmil ECA
- XLPE = Cross-Link Polyethylene Covering
- HDPE = High Density Polyethylene Covering
- ACSR = Aluminum Cable Steel Reinforced
- CCW = Copper – Copperweld
- ECA = Electrical Conductivity Aluminum, also known as “All Aluminum” or “AAC”
- HD = Hard Drawn Copper
- SD = Soft Drawn Copper

<b>PRIMARY CONDUCTORS</b>			
	<b>OVERHEAD CONSTRUCTION STANDARD</b>	<b>PAGE NUMBER</b>	<b>ISSUE</b>
		<b>6-1</b>	<b>4/25</b>

Copyright 2021 PPL. For information regarding property rights, confidentiality and use see Section 1.  
Printed copies of this document are not document controlled. Refer to the PPL SKY, Distribution Engineering Services website, for the latest version.  
Controlled copies are maintained in Documentum.

Doc. # ST. 06.00.002

- Note 1 – The outer layer on aluminum cable shall be right-hand twist (on copper, left-hand twist).*
- Note 2 – A Mylar separator shall not be included between the conductor and the insulation.*
- Note 3 – Manufacturer’s identification shall be printed on the outside of the covered conductor covering.*
- Note 4 – Although tree wire /spacer cable and other covered line conductors offer some electrical protection, it is **NOT INSULATED CONDUCTOR** and shall not be depended upon in this respect.*

**Loading Definitions**

**Deadend** - Maximum tensions that will exist under conditions of “Heavy Loading” in conductors strung to standard sags. Values for NESC Grades B & C are based on 60% rated breaking strength; however, a 50% rated breaking strength value shall be employed for all new work. Values for Grade N are based on 70% rated breaking strength. These are furnished for use when maintaining existing Grade N lines. Use these values for guy and pole strength calculations and for calculation of crossarm strength at deadends.

**Transverse** - Loads resulting from a 4 lb./sq.foot wind blowing at right angles to the line with conductors covered by ½ inch ice (Heavy Loading) NESC Rule 250B OR Loads resulting from (110mph or 25.6 PSF) blowing at right angles with conductors free of ice NESC Rule 250C. Use whatever is more conservative NESC Rule 250B vs NESC Rule 250C values for transverse guy and pole strength calculations.

**Vertical** - Weight of conductors plus ½ inch radial ice. Use these values for calculations of vertical crossarm strength.

MATERIAL DESCRIPTION			
ISSUE	PAGE NUMBER	OVERHEAD CONSTRUCTION STANDARD	
4/25	22 – D1C – D7D		

© 2022 PPL Corporation. All rights reserved.	Doc. # ST. 06.00.002
----------------------------------------------	----------------------

**Total** - Total resultant of vertical and transverse loads on conductors under “Heavy Loading” plus an adder of 0.30 lbs./foot (Total Load =  $\sqrt{T^2 + V^2} + 0.3$  lbs./foot). Use for slack span calculations and for other sag and tension problems.

**Swing Angle** - Angle at which the conductor will be displaced from the vertical by a 6 lbs./sq. foot wind blowing at right angles to the line at 60°F/15°C. Use these values for horizontal clearance calculations. Calculate horizontal displacement by R sine  $\alpha$  where R = max. sag and  $\alpha$  = swing angle.

$$\text{Swing Angle} = \alpha = \tan^{-1} \left( \frac{W_h}{W_v} \right)$$

$$W_h = \frac{P}{12} \times d \qquad P = 6 \text{ (6 lbs./sq. foot), 12 Inch Conductor Length}$$

$d$  = Conductor Diameter

$W_v$  = Unloaded Weight of Conductor (lbs./foot)

## 6.2 SAGS AND TENSIONS

All overhead lines must meet minimum clearance requirements of the NESC in force at the time the line is constructed. Prior to the 1977 issue of the NESC, minimum basic clearances allowed for increased sag due to ice loading or operation at a 120°F/50°C maximum conductor temperature.

The 1977 revision to the NESC, under Rule 232B2, permits the owner to establish a conductor maximum operating temperature while maintaining minimum clearance requirements. The Company has established a 176°F/80°C maximum allowable conductor operating temperature under normal conditions and a 194°F/90°C maximum allowable conductor operating temperature under emergency conditions for a specific period of time.

### 6.2.10 Limiting Tensions

In the design of overhead lines, three limiting values of tension shall be observed:

- A. Initial Unloaded or Stringing Tension is that which will exist before the application of any external load or immediately after new conductors have been installed. The initial unloaded tension at 0°F/18°C shall not exceed 35% of rated breaking strength. The temperature of 0°F/18°C is used instead of 60°F/15°C required by the NESC because the aluminum manufacturers have indicated that 0°F/18°C is more critical for aluminum than 60°F/15°C. Although it is not necessary, the 0°F/18°C tension is used for conductors other than aluminum to be consistent.
- B. Maximum Design Tension is that to which the conductor is subjected upon occurrence of the maximum climatic loading specified for design work in the NESC Heavy Loading area. The maximum conductor tension, either initial or final, shall not exceed 50% of rated breaking strength. This limit is less than the 60% required by the NESC to allow for higher tensions due to spans longer than the ruling span and to allow for slight tolerances in sagging. A 2,000 lb. tension limitation is common for most distribution conductors, especially those that deadend on crossarms. All conductors except spacer cable messengers and specially noted conductors shall be limited to an approximate maximum tension of 2000 lbs. A 3,000 lb. tension limitation is acceptable, with appropriate hardware, in situations where the resulting line has a clear advantage over standard 2,000 lb. design because of lower costs due to longer spans or improved appearance of the line.
- C. Final Unloaded Tension is that which the conductor assumes under no external loading but after the maximum design tension has been sustained for sufficient time to permit stretching to cease. The final unloaded tension at 0°F/18°C shall not exceed 25% of

<b>PRIMARY CONDUCTORS</b>			
	<b>OVERHEAD CONSTRUCTION STANDARD</b>	<b>PAGE NUMBER</b>	<b>ISSUE</b>
		<b>6-3</b>	<b>1/07</b>

rated breaking strength. The 0°F/18°C tension is used for the same reason as in the above criteria A.

The sag tables demonstrate sags under various temperatures and loading conditions. New conductors strung to “Stringing” (Initial) values will have initial, maximum and final tensions as specified. The sag will increase under design loading, then change as shown in “Final” sags depending on temperature and loading.

The Initial Sag tables are based on the Ruling Span Method of calculation and the Final Sag tables are based on the Deadend Method, as discussed below. In the event that Initial or Final Sags that are not shown are required, contact Standards Engineering.

**6.2.20 Deadend or Uniform Spans**

Sag tables based on deadend span methods assume that there is only one span or that all spans are the same length. This method is useful for short spans in urban areas where the spacing is reasonably uniform. If long spans in a section of line are sagged according to a deadend table, short spans in the same section will have a sag value that may or may not correspond with the table. For this reason, it is customary to sag a span of average length near the center of the line and to recognize that there may be slightly more or less sag in the longer and shorter spans than is indicated by the tables.

In order to determine the sag value for a specific span length, multiply the ruling span sag value by the ratio provided in Table 1 for the corresponding actual span length. In the event that the needed actual span length is not provided in this table, a method for determining the resultant ratio value is provided below.

**Table 1  
Ratio of Deadend Span Sag to Sags at Other Span Lengths with Same Tension**

ACTUAL SPAN	DEADEND SPAN										
	50'	75'	100'	125'	150'	175'	200'	225'	250'	275'	300'
100'	4.00	1.78	1.00	0.64	0.44	0.33	0.25	0.20	0.16	0.13	0.11
110'	4.84	2.15	1.21	0.77	0.54	0.40	0.30	0.24	0.19	0.16	0.13
120'	5.76	2.56	1.44	0.92	0.64	0.47	0.36	0.28	0.23	0.19	0.16
130'	6.76	3.00	1.69	1.08	0.75	0.55	0.42	0.33	0.27	0.22	0.19
140'	7.84	3.48	1.96	1.25	0.87	0.64	0.49	0.39	0.31	0.26	0.22
150'	9.00	4.00	2.25	1.44	1.00	0.73	0.56	0.44	0.36	0.30	0.25
160'	10.24	4.55	2.56	1.64	1.14	0.84	0.64	0.51	0.41	0.34	0.28
170'	11.56	5.13	2.89	1.85	1.28	0.94	0.72	0.57	0.46	0.38	0.32
180'	12.96	5.76	3.24	2.07	1.44	1.06	0.81	0.64	0.52	0.43	0.36
190'	14.44	6.42	3.61	2.31	1.60	1.18	0.90	0.71	0.58	0.48	0.40
200'	16.00	7.11	4.00	2.56	1.78	1.31	1.00	0.79	0.64	0.53	0.44
210'	17.64	7.84	4.41	2.82	1.96	1.44	1.10	0.87	0.71	0.58	0.49
220'	19.36	8.60	4.84	3.10	2.15	1.58	1.21	0.96	0.77	0.64	0.54
230'	21.16	9.40	5.29	3.39	2.35	1.73	1.32	1.04	0.85	0.70	0.59
240'	23.04	10.24	5.76	3.69	2.56	1.88	1.44	1.14	0.92	0.76	0.64
250'	25.00	11.11	6.25	4.00	2.78	2.04	1.56	1.23	1.00	0.83	0.69

Method for Determining Ratio:

1. Choose Deadend Span.
2. Find deadend span sag from sag table for temperature and deadend span desired.
3. Multiply deadend span sag by above ratio for actual spans as line is laid out to obtain actual span.
4. For deadend span to actual span ratio other than those listed above:

<b>PRIMARY CONDUCTORS</b>			
<b>ISSUE</b>	<b>PAGE NUMBER</b>	<b>OVERHEAD CONSTRUCTION STANDARD</b>	
<b>1/07</b>	<b>6-2</b>		

$$RATIO = \frac{(ACTUAL SPAN)^2}{(DEADEND SPAN)^2}$$

**6.2.30 Ruling Spans**

This is a calculated span length for which the conductor tension, under changes in temperature and loading, best represents the average tension in the conductor in a particular series of spans between deadends. Ideally, a line should be installed in such a way that all spans of the line have equal horizontal line tension. If this is done, longitudinal forces on pole tops between spans are theoretically zero. Deadend poles and poles located at bends in the line will typically require guying in order to counteract the line tension.

Sag tables based on the ruling span method recognize variations in span length. This method assumes that the line will be strung to uniform tension. If this is done, all spans will have initial sags that are very near the values in the table. After the conductors are tied into place, however, and after ice and wind loads stretch the wires, the tension may not be uniform and the sags may vary from the calculated values. If the actual spans are much longer or shorter than the ruling span, the tension and sags may be different than the calculations.

The ruling span can most accurately be determined through the following equation:

$$\text{Ruling Span} = \sqrt{\frac{(L_1^3 + L_2^3 + L_3^3 + \dots L_N^3)}{(L_1 + L_2 + L_3 + \dots L_N)}}$$

Where L<sub>1</sub>, L<sub>2</sub>, L<sub>3</sub>, etc. are the lengths of the first, second, third, etc., spans between deadends.

Spans that are longer than 150% of the average should be avoided or should be sagged independently and guyed to hold the unbalanced tension. All new standard construction for tension should conform to the Company's design which limits tension to 50% of the conductor rated breaking strength by following the above mentioned ruling span calculation.

**6.2.40 Slack Spans**

When guys cannot be installed on the end pole of a line, they may be placed on an adjacent pole. A slack span should then be installed to the end pole. Slack spans may also be necessary for other applications. They are not recommended if there is any way of avoiding them, but when used, calculations should be made as follows:

$$\text{String Sag in Feet} = \frac{W \times L^2}{8 \times T}$$

- W = Total loaded weight lbs./ft.
- L = Total length of span in ft.
- T = Tension in pounds. See Section 2-Poles / Hardware for strength required in poles.

*Example:*

50 foot span, 3-336.4 kcmil bare AAC to be deadended on an un-guyed Class 5 pole.  
Use T = 200 lb. per conductor.

- W = 1.48 lbs./foot (from Page 6-121)
- L = 50 feet (span length)
- T = 200 lbs.

<b>PRIMARY CONDUCTORS</b>			
	<b>OVERHEAD CONSTRUCTION STANDARD</b>	<b>PAGE NUMBER</b>	<b>ISSUE</b>
		<b>6-3</b>	<b>1/07</b>

$$S = \frac{W \times L^2}{8 \times T} = \frac{1.48 \times 50^2}{8 \times 200} = \frac{3700}{1600} = 2.3125 \text{ Feet}$$

Sag the conductor at 2.31 feet, at normal temperature. This approximation *assumes* that the conductors will have 2.31 feet of sag at 0°F/18°C when subject to ice and wind.

### 6.3 MAXIMUM SPANS

Maximum spans, as shown in the table or on the pole top drawings, are based on many factors including: sag vs. pole height, transverse load vs. pole strength, vertical weight vs. strength of crossarms, and ratio of sag to separation of conductors. Spans are limited so that standard poles of reasonable height and class may be used for most work. They also are limited to reduce probability of wires coming together due to wind effects.

Span length should be limited to recommended values for all normal work. Longer spans may be used, except at railroad or major crossings, if clearances are adjusted accordingly. If longer spans are still essential, separate deadend spans should be designed by Standards Engineering to meet the field conditions.

### 6.4 AMPACITY

Current in overhead line conductors should be limited so that voltage drops will be held to reasonable values; so that conductors will not be severely annealed or damaged; so that switches, connectors, etc. will not be overloaded and that clearances are not exceeded. Any feeder that is desired to be operated at the elevated operating temperature permitted for emergency conditions should be assessed to verify that available clearances are present to account for the resulting additional sag as outlined in each respective conductor data table. Minimum clearances, outlined in Section 7 – Clearances, should not be compromised.

**Table 2**  
**Ampacity Design Parameters**

SPECIFICATION	BARE CONDUCTOR	TREE WIRE
	SUMMER / WINTER	SUMMER / WINTER
Maximum Allowable Steady State Conductor Temperature (°C) For Normal Operating Conditions	176°F/80°C	167°F/75°C
Maximum Allowable Steady State Conductor Temperature (°C) For Emergency Contingencies	194°F/90°C	194°F/90°C
Ambient Air Temperature (°C)	100°F/37.7°C / 50°F/10°C	100°F/37.7°C / 50°F/10°C
Wind Speed (FT. / SEC.)	3 FEET/SEC.	3 FEET/SEC.
Angle between Wind and Conductor	90°	90°
Coefficient of Emissivity	0.75	0.91
Coefficient of Absorption	0.75	0.91
Climatic Data Record (CDR) elevation above sea level (FT.)	914.2125 FEET	914.2125 FEET
Conductor Direction (North – South, East – West)	North – South	North – South
CDR Latitude in Degrees	42°	42°
Solar Heating	12:00 PM (noon)/NONE	12:00 PM (noon)/NONE
Atmosphere	CLEAR	CLEAR
Conductor Resistance in Ohm/mi. for the Low Temperature @ 77°F/25°C	Conductor Specific – In Accordance with Low Conductor Temperature	Conductor Specific – In Accordance with Low Conductor Temperature
Conductor Resistance in Ohm/mi. for the High Temperature @ 167°F/75°C	Conductor Specific – In Accordance with High Conductor Temperature	Conductor Specific – In Accordance with High Conductor Temperature

CONDUCTORS			
ISSUE	PAGE NUMBER	OVERHEAD CONSTRUCTION STANDARD	
5/05	6 - 4		

The “Normal” rating is the maximum rating for daily operation without encountering excessive loss of life, etc. and accounting for load cycles as well as ambient temperature cycles. Limits are based on allowable sags, clearance issues, and avoiding damage. The “Emergency” rating is the ultimate or maximum rating for a specific period of time, accounting for peak load cycle and ambient temperature cycles, without enduring excessive loss of life. Emergency ratings are applicable to short-term relief and should not exceed a 24 hour load cycle. For design purposes, emergency ratings exceeding a full load cycle were assumed resulting in a conductor rating that does not promote excessive loss of conductor life during such contingencies. This more conservative view was used for overhead conductors because of the concern for a permanent annealing of the conductor. For overhead conductors, such annealing could result in excess sag, and ultimately create clearance issues. In any case, the “Emergency” ampacity rating should not be exceeded nor allowed for prolonged duration in excess of 24 hours.

Primary overhead conductors have two (2) ampacity ratings for summer conditions and two (2) ampacity ratings for winter conditions as defined below:

- Normal: The Normal rating shall be interpreted as the maximum value for normal peak loads on all new and rebuilt feeders. This is done to accommodate emergency conditions where ampacity may be increased for a period of time no greater than 24 hours. Existing feeders may be loaded to these levels if a review indicates that appropriate clearances can be maintained. (100% ampacity for normal operating conductor temperature limit; 176°F/80°C for bare conductors, 167°F/75°C for spacer cable / tree wire / covered conductors)
- Emergency: The Emergency rating shall be interpreted as the absolute maximum ampacity allowed for a given conductor. This ampacity should not be exceeded under any condition unless an appropriate engineering review has been conducted. (100% ampacity for operating conductor at an elevated temperature during emergency conditions limited to a 24 hour period; 194°F/90°C for both bare and spacer cable / tree wire / covered conductors)

## 6.5 PLANNING CONDUCTOR INSTALLATIONS

### 6.5.10 General

Background knowledge of conductor sag and tensions, and ampacity are essential for all phases of planning, as well as determining the appropriate conductor, pole class and height, guy designs, etc. Designs will also be influenced by features that are discussed in specific Sections of these standards, including: Primaries, Street Lighting, and Secondaries.

The size for conductor should follow planning criteria or reviewed by a distribution system planning engineer. The distribution designer who selects the materials should furnish guidance to the field whenever it is required. For example, the distribution designer should furnish stringing sags at 32°F/0°C, 60°F/15°C, and 90°F/32°C and should indicate the spans that should be checked for sag whenever ruling span or slack span sag is needed.

For normal urban work refer to the standard tables, or curves, with variations discussed in Section 22-Materials Catalog.

### 6.5.20 Employment of 3,000 lb. Maximum Design Tension

Advantages of using design tensions greater than 2,000 lbs. may be substantial under certain circumstances. The advantages include reduced costs, avoiding need for intermediate poles when converting from single phase to three phase, and improved appearance resulting from fewer poles. If advantages like this are clearly evident, 3,000 lb. span construction may be used

CONDUCTORS			
	<b>OVERHEAD CONSTRUCTION STANDARD</b>	<b>PAGE NUMBER</b>	<b>ISSUE</b>
		<b>6 - 5</b>	<b>5/05</b>

for three phase lines in rural areas where the presence of secondaries and telephone is minimal and future urbanization is not anticipated. Isolated situations where conventional construction results in excessive sag may also be justification for 3,000 lb. construction. Crossarm tangents, vertical construction, deadends, and 336.4 kcmil or 477 kcmil 18/1 bare ACSR conductors should be employed for 3000 lb construction. Heavy duty arms with gain plates should be used where vertical construction for line angle poles and double deadends are not practical. The 3,000 lb. section of line shall be isolated from 2,000 lb. line sections by proper longitudinal guys at each end.

**6.5.30 Deadending Different Conductors**

When different conductors are deadended from the opposite directions on the same pole, the load may be balanced under heavy load conditions but not under normal temperatures. Normal conditions must exist when the foreman installs the cable. Three 336.4 kcmil and one 1/0 ACSR conductors, for example, create an unbalanced load of about 8,000 lbs. under heavy loading conditions. One spacer cable messenger will almost balance this with a tension of 7,700 lbs. Under pre-stressed conditions, the spacer cable will be stressed to 5,000 lbs. The open wires, however, will have tensions not over 400 or 500 lbs. each or less than 2,000 lbs. total. For this reason, the spacer cable must be deadended and guyed against the stress. Similar conditions will be met when two small conductors are balanced against one large one. A head guy to the next pole will often be sufficient to take up small unbalanced loads.

**6.6 INSTALLING CONDUCTORS**

**6.6.10 General**

In order to obtain the desired tensions it is essential that the conductor be sagged correctly. This Standard has been prepared to guide the installation of conductors.

**6.6.20 Sagging Open Wire Primaries – Long Span**

For long span work or for special construction, the planner will usually select a ruling span, pick the span that should be sagged, choose the stringing sags, and show them on the construction drawing. If conditions in the field make it impractical to sag this span, the planner should be consulted and the new stringing sags provided.

**6.6.30 Sagging Other Open Conductors**

Where special conditions warrant, the planner may select the span to be sagged and choose the stringing sags. In many cases, however, the sags will not be specified. In these cases proceed as follows:

- A. Choose a span of average length near the center of the section to be pulled.
- B. Check the stringing sag tables for a span of that length at the temperature that can be expected during the sagging operations. If the exact span is not shown on the table, use the corresponding ratio multiplier found in Table 1 on Page 6-3 to determine the required value.

If the actual ruling span is not specified, choose a ruling span that is equal to, or slightly more than, the actual span.

If existing conductors are to be re-sagged or re-strung, see Part E below.

<b>PRIMARY CONDUCTORS</b>			
<b>ISSUE</b>	<b>PAGE NUMBER</b>	<b>OVERHEAD CONSTRUCTION STANDARD</b>	
<b>1/07</b>	<b>6-6</b>		

- C. Pull up the entire section, equalizing tension in each span. Check the sag in the key span using a sagging stick or scale. Spans of other lengths will not necessarily have sags that match the stringing tables.
- D. When different conductors are strung in parallel (e.g. on the same arm) string them to the value of the conductor with the greatest sag. It may be necessary to provide extra clearance for the wires so sagged.
- E. When re-sagging or re-stringing old conductors, they should first be pulled tightly to sags somewhat less than final values, and then backed off to meet the final sag curves.

**6.6.40 Line of Sight Method of Sagging Conductors**

Select the longest span near the center of the line being sagged. Determine the proper stringing sag from the appropriate sag table. Measure down this distance "X" on both poles of the span from the height of the conductor attachment to the pole (see Figure 1 on Page 6-8). Attach a marker at this point that can be seen from the other pole. The conductor should be sagged to the line of sight between the two markers. The sag should be as close as practical to the stringing sag shown in the sag tables. Decreased sags cause tensions greater than design tensions and may overstress conductors, poles, crossarms and guys. Increased sags cause clearances smaller than design clearance.

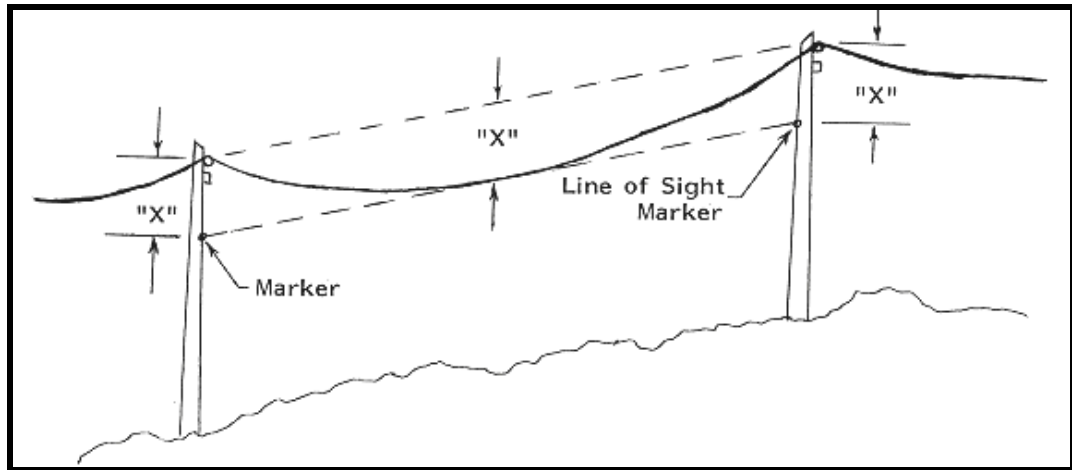

**Figure 1 – Line of Sight Method of Sagging Conductors**

<b>CONDUCTORS</b>			
	<b>OVERHEAD CONSTRUCTION STANDARD</b>	<b>PAGE NUMBER</b>	<b>ISSUE</b>
		<b>6 - 9</b>	<b>5/05</b>

© 2022 PPL Corporation. All rights reserved.	Doc. # ST.06.00.003
----------------------------------------------	---------------------

# Standard Overhead Distribution Conductors

STANDARD OVERHEAD DISTRIBUTION CONDUCTORS			
	OVERHEAD CONSTRUCTION STANDARD	PAGE NUMBER	ISSUE
		6-100	1/07

© 2022 PPL Corporation. All rights reserved.	Doc. # ST.06.00.003
----------------------------------------------	---------------------

Std. Item:	W21NG
Item ID:	9302828 <sup>E</sup>
CU:	C1113ASSTBRNE

PHYSICAL PROPERTIES		LOADING PROPERTIES		ELECTRICAL PROPERTIES		
R.B.S.	39,100 lbs.	TRANSVERSE	0.7634 Lb/Ft	SUMMER (37.7°C)	MAXIMUM AMPACITY	WINTER (10°C)
C.S.A.	0.9854 sq. in.	VERTICAL	2.546 Lb/Ft			
R. (@ 25°C)	0.0161 Ω / 1000'	TOTAL	2.958 Lb/Ft	1111	NORMAL	1614
R. (@ 75°C)	0.0191 Ω / 1000'			1262	EMERGENCY	1709
TEMP. LIMIT	176°F (80°C) / 194°F (90°C)	SWING	24.33°			
CONDUCTOR DIAMETER	1.293"					
WEIGHT	1430 lbs / 1000'					

INITIAL SAG TABLE																
TEMP. °F	RULING SPAN (FEET)															
	125				150				175				200			
	0	32	60	90	0	32	60	90	0	32	60	90	0	32	60	90
TEMP. °C	-18	0	15	32	-18	0	15	32	-18	0	15	32	-18	0	15	32
TENSION (LBS.)	2672	1772	1394	1162	2461	1810	1499	1287	2318	1837	1578	1389	2208	1857	1639	1471
ACTUAL SPAN (FEET)																
50	2	3	4	5	2	3	4	4	2	3	3	4	2	3	3	4
60	3	4	6	7	3	4	5	6	3	4	5	6	3	4	5	5
70	4	6	8	9	4	6	7	8	5	6	7	8	5	6	6	7
80	5	8	10	12	6	8	9	11	6	7	9	10	6	7	8	9
90	7	10	12	15	7	10	12	14	8	9	11	13	8	9	11	12
100	8	12	15	18	9	12	14	17	9	12	14	15	10	12	13	15
110	10	15	19	22	11	14	17	20	11	14	16	19	12	14	16	18
120	12	17	22	27	13	17	21	24	13	17	20	22	14	17	19	21
130	14	20	26	31	15	20	24	28	16	20	23	26	16	20	22	25
140	16	24	30	36	17	23	28	33	18	23	27	30	19	23	26	29
150	18	27	35	42	20	27	32	38	21	26	31	35	22	26	29	33
160	21	31	39	47	22	30	37	43	24	30	35	40	25	30	34	37
170	23	35	45	53	25	34	41	48	27	34	39	45	28	33	38	42
180	26	39	50	60	28	38	46	54	30	38	44	50	32	37	42	47
190	29	44	56	67	31	43	52	60	33	42	49	56	35	42	47	53
200	32	48	62	74	35	47	57	67	37	47	54	62	39	46	52	58
210	35	53	68	82	38	52	63	74	41	52	60	68	43	51	58	64
220	39	59	75	90	42	57	69	81	45	57	66	75	47	56	63	71
230	43	64	82	98	46	63	76	88	49	62	72	82	51	61	69	77
240	46	70	89	107	50	68	83	96	53	67	78	89	56	67	75	84
250	50	76	96	116	55	74	90	104	58	73	85	97	61	72	82	91
260	54	82	104	125	59	80	97	113	63	79	92	105	66	78	89	99
270	59	88	112	135	64	87	105	122	68	85	99	113	71	84	96	107
280	63	95	121	145	68	93	112	131	73	92	107	121	76	91	103	115
290	68	102	130	156	73	100	121	141	78	98	115	130	82	97	110	123
300	72	109	139	167	79	107	129	150	83	105	123	139	88	104	118	132

\*\*\* Simulated with a maximum tension of 4000 lbs. \*\*\*

1113.0 KCMIL, 54/19 STRANDING, BARE ACSR, "FINCH" – 35 kV			
ISSUE	PAGE NUMBER	OVERHEAD CONSTRUCTION STANDARD	
7/15	6-101		

© 2022 PPL Corporation. All rights reserved.

Doc. # ST.06.00.003

Std. Item:	W21NG
Item ID:	9302828 <sup>E</sup>
CU:	C1113ASSTBRNE

FINAL SAG TABLE								
TEMP. °F	LOADING (UNLOADED CONDITIONS)							
	0	32	60	90	120	158	176	194
TEMP. °C	-18	0	15	32	50	70	80	90
	Unloaded	Unloaded	Unloaded	Unloaded	Unloaded	Unloaded	Unloaded	Unloaded
DEAD END SPAN (FEET)								
50	1.44	4.20	7.20	8.64	9.84	11.28	11.88	12.48
75	3.84	8.28	12.12	14.40	16.08	18.00	18.84	19.68
100	7.68	13.44	18.00	21.36	23.40	25.68	26.76	27.84
125	13.32	20.04	25.08	29.28	31.68	34.44	35.64	36.84
150	20.64	27.84	33.24	38.40	41.16	44.16	45.60	46.92
175	29.40	36.96	42.72	48.36	51.72	55.08	56.64	58.08
200	39.72	47.40	53.52	59.52	63.48	67.08	68.76	70.32
225	51.48	59.28	65.64	71.76	76.44	80.28	81.96	83.76
250	64.56	72.60	79.08	85.44	90.48	94.68	96.48	98.28
275	79.08	87.24	93.84	100.44	105.60	110.28	112.20	114.12
300	95.04	103.20	109.92	116.64	122.04	127.08	129.12	131.16

FINAL SAG TABLE				
TEMP. °F	LOADING (LOADED CONDITIONS)			TENSION (LBS.)
	0	32	60	0
TEMP. °C	-18	0	15	-18
	4 LB. WIND, ½" ICE	½" ICE	6 LB. WIND	4 LB. WIND, ½" ICE
DEAD END SPAN (FEET)				
50	2.76	5.16	7.32	*4000
75	6.24	9.60	12.24	*4000
100	11.04	15.24	18.12	*4000
125	17.28	22.08	25.20	*4000
150	24.96	30.12	33.48	*4000
175	33.96	39.48	43.08	*4000
200	44.40	50.16	53.88	*4000
225	56.16	62.16	65.88	*4000
250	69.36	75.60	79.32	*4000
275	84.00	90.24	94.08	*4000
300	99.96	106.32	110.28	*4000

\* Note: Design Specification Constraint

\*\*\* Simulated with a maximum tension of 4000 lbs. \*\*\*

1113.0 KCMIL, 54/19 STRANDING, BARE ACSR, "FINCH" – 35 kV			
	OVERHEAD CONSTRUCTION STANDARD	PAGE NUMBER	ISSUE
		6-102	7/15

© 2022 PPL Corporation. All rights reserved. Doc. # ST.06.00.003

Std. Item:	W21NF
Item ID:	9306375 <sup>E</sup>
CU:	C795ASSTBRNE

PHYSICAL PROPERTIES		LOADING PROPERTIES		ELECTRICAL PROPERTIES		
R.B.S.	28,200 lbs.	TRANSVERSE	0.6966 Lb/Ft	SUMMER (37.7°C)	MAXIMUM AMPACITY	WINTER (10°C)
C.S.A.	0.7049 sq. in.	VERTICAL	2.015 Lb/Ft			
R. (@ 25°C)	0.0222 Ω / 1000'	TOTAL	2.432 Lb/Ft	902	NORMAL	1299
R. (@ 75°C)	0.0265 Ω / 1000'			1021	EMERGENCY	1375
TEMP. LIMIT	176°F (80°C) / 194°F (90°C)	SWING	28.14°			
CONDUCTOR DIAMETER	1.093"					
WEIGHT	1022 lbs / 1000'					

INITIAL SAG TABLE																
RULING SPAN (FEET)																
TEMP. °F	125				150				175				200			
	0	32	60	90	0	32	60	90	0	32	60	90	0	32	60	90
TEMP. °C	-18	0	15	32	-18	0	15	32	-18	0	15	32	-18	0	15	32
TENSION (LBS.)	2446	1557	1165	938	2192	1537	1228	1028	2004	1523	1274	1100	1874	1513	1310	1157
ACTUAL SPAN (FEET)																
50	2	2	3	4	2	2	3	4	2	3	3	3	2	3	3	3
60	2	4	5	6	3	4	5	5	3	4	4	5	3	4	4	5
70	3	5	6	8	3	5	6	7	4	5	6	7	4	5	6	7
80	4	6	8	10	4	6	8	10	5	6	8	9	5	6	8	8
90	5	8	11	13	6	8	10	12	6	8	10	11	7	8	10	11
100	6	10	13	16	7	10	13	15	8	10	12	14	8	10	12	13
110	8	12	16	20	8	12	15	18	9	12	15	17	10	12	14	16
120	9	14	19	24	10	14	18	22	11	15	17	20	12	15	17	19
130	11	17	22	28	12	17	21	25	13	17	20	24	14	17	20	22
140	12	19	26	32	14	20	25	29	15	20	24	27	16	20	23	26
150	14	22	30	37	16	22	28	34	17	23	27	31	18	23	26	30
160	16	25	34	42	18	26	32	38	20	26	31	36	21	26	30	34
170	18	29	38	47	20	29	36	43	22	29	35	40	24	29	34	38
180	20	32	43	53	23	32	41	48	25	33	39	45	27	33	38	43
190	23	36	48	59	25	36	45	54	28	36	44	50	30	37	42	48
200	25	39	53	66	28	40	50	60	31	40	48	56	33	41	47	53
210	28	44	58	72	31	44	55	66	34	45	53	62	36	45	52	59
220	30	48	64	79	34	48	61	72	37	49	58	68	40	49	57	64
230	33	52	70	87	37	53	66	79	41	53	64	74	43	54	62	70
240	36	57	76	94	40	58	72	86	44	58	69	81	47	59	68	77
250	39	62	82	103	44	62	78	94	48	63	75	87	51	63	73	83
260	42	67	89	111	47	68	85	101	52	68	82	95	55	69	79	90
270	46	71	96	120	51	73	91	109	56	74	88	102	60	74	85	97
280	49	77	103	129	55	78	98	117	60	79	95	110	64	80	92	104
290	53	83	111	138	59	84	105	126	64	85	101	118	69	85	99	112
300	57	89	119	148	63	90	113	135	69	91	109	126	74	91	106	120

\*\*\* Simulated with a maximum tension of 3500 lbs. \*\*\*

795.0 KCMIL, 54/7 STRANDING, BARE ACSR, "CONDOR" – 35 kV			
ISSUE	PAGE NUMBER	OVERHEAD CONSTRUCTION STANDARD	
7/15	6-103		

© 2022 PPL Corporation. All rights reserved. Doc. # ST.06.00.003

Std. Item:	W21NF
Item ID:	9306375 <sup>E</sup>
CU:	C795ASSTRNE

FINAL SAG TABLE								
TEMP. °F	LOADING (UNLOADED CONDITIONS)							
	0	32	60	90	120	158	176	194
TEMP. °C	-18	0	15	32	50	70	80	90
	Unloaded	Unloaded	Unloaded	Unloaded	Unloaded	Unloaded	Unloaded	Unloaded
DEAD END SPAN (FEET)								
50	1.20	3.00	6.00	7.68	9.00	10.44	11.16	11.76
75	3.00	6.36	10.44	13.20	14.88	16.92	17.76	18.72
100	5.88	11.16	15.84	19.68	21.72	24.24	25.32	26.40
125	10.56	17.04	22.44	27.12	29.52	32.40	33.72	35.04
150	16.92	24.36	30.12	35.52	38.40	41.64	43.08	44.52
175	24.96	32.88	39.00	44.88	48.36	51.84	53.40	55.08
200	34.44	42.60	49.08	55.20	59.28	63.12	64.92	66.60
225	45.36	53.76	60.36	66.84	71.40	75.48	77.40	79.20
250	57.72	66.12	72.96	79.68	84.72	89.04	90.96	93.00
275	71.28	79.92	86.76	93.72	99.24	103.80	105.84	107.76
300	86.28	94.92	101.88	109.08	114.84	119.64	121.80	123.84

FINAL SAG TABLE				
TEMP. °F	LOADING (LOADED CONDITIONS)			TENSION (LBS.)
	0	32	60	0
TEMP. °C	-18	0	15	-18
	4 LB. WIND, ½" ICE	½" ICE	6 LB. WIND	4 LB. WIND, ½" ICE
DEAD END SPAN (FEET)				
50	2.64	4.32	6.12	*3500
75	5.88	8.40	10.68	*3500
100	10.44	13.80	16.20	*3500
125	16.32	20.16	22.80	*3500
150	23.40	27.84	30.48	*3500
175	31.92	36.72	39.36	*3500
200	41.76	46.80	49.56	*3500
225	52.80	58.08	60.84	*3500
250	65.16	70.68	73.56	*3500
275	78.84	84.48	87.36	*3500
300	93.84	99.60	102.48	*3500

\* Note: Design Specification Constraint

\*\*\* Simulated with a maximum tension of 3500 lbs. \*\*\*

795.0 KCMIL, 54/7 STRANDING, BARE ACSR, "CONDOR" – 35 kV			
	OVERHEAD CONSTRUCTION STANDARD	PAGE NUMBER	ISSUE
		6-104	7/15

© 2022 PPL Corporation. All rights reserved.

Doc. # ST.06.00.003

Std. Item:	W21BF
Item ID:	9302781 <sup>E</sup>
CU:	C795ALSTBRNE

PHYSICAL PROPERTIES		LOADING PROPERTIES		ELECTRICAL PROPERTIES		
R.B.S.	13,900 lbs.	TRANSVERSE	0.675 Lb/Ft	SUMMER (37.7°C)	MAXIMUM AMPACITY	WINTER (10°C)
C.S.A.	0.6245 sq. in.	VERTICAL	1.694 Lb/Ft			
R. (@ 25°C)	0.0227 Ω / 1000'	TOTAL	2.124 Lb/Ft	880	NORMAL	1265
R. (@ 75°C)	0.0269 Ω / 1000'			997	EMERGENCY	1339
TEMP. LIMIT	176°F (80°C) / 194°F (90°C)	SWING	34.54°			
CONDUCTOR DIAMETER	1.026"					
WEIGHT	745 lbs / 1000'					

INITIAL SAG TABLE																
TEMP. °F	RULING SPAN (FEET)															
	125				150				175				200			
	0	32	60	90	0	32	60	90	0	32	60	90	0	32	60	90
TEMP. °C	-18	0	15	32	-18	0	15	32	-18	0	15	32	-18	0	15	32
TENSION (LBS.)	868	657	554	484	811	669	588	527	779	676	612	560	760	682	629	585
ACTUAL SPAN (FEET)																
50	3	4	5	6	3	4	5	5	4	4	5	5	4	4	4	5
60	5	6	7	8	5	6	7	8	5	6	7	7	5	6	6	7
70	6	8	10	11	7	8	9	10	7	8	9	10	7	8	9	9
80	8	11	13	15	9	11	12	14	9	11	12	13	9	11	11	12
90	10	14	16	19	11	14	15	17	12	13	15	16	12	13	14	16
100	13	17	20	23	14	17	19	21	14	17	18	20	15	16	18	19
110	16	21	24	28	17	20	23	26	17	20	22	24	18	20	22	23
120	19	25	29	33	20	24	27	31	21	24	26	29	21	24	26	28
130	22	29	34	39	23	28	32	36	24	28	31	34	25	28	30	32
140	25	33	40	45	27	33	37	42	28	33	36	39	29	32	35	38
150	29	38	45	52	31	38	43	48	32	37	41	45	33	37	40	43
160	33	44	52	59	35	43	49	54	37	42	47	51	38	42	46	49
170	37	49	58	67	40	48	55	61	42	48	53	58	43	48	51	55
180	42	55	65	75	45	54	62	69	47	54	59	65	48	53	58	62
190	47	62	73	83	50	60	69	77	52	60	66	72	53	59	64	69
200	52	68	81	92	55	67	76	85	58	66	73	80	59	66	71	77
210	57	75	89	102	61	74	84	94	63	73	81	88	65	73	79	85
220	62	82	98	112	67	81	92	103	70	80	89	97	71	80	86	93
230	68	90	107	122	73	89	101	113	76	88	97	106	78	87	94	102
240	74	98	116	133	80	96	110	123	83	96	106	115	85	95	103	111
250	81	107	126	144	86	105	119	133	90	104	115	125	92	103	111	120
260	87	115	137	156	93	113	129	144	97	112	124	135	100	111	120	130
270	94	124	147	169	101	122	139	155	105	121	134	146	108	120	130	140
280	101	134	158	181	108	131	149	167	113	130	144	157	116	129	140	151
290	109	143	170	194	116	141	160	179	121	139	154	168	124	138	150	161
300	116	153	182	208	124	151	171	192	129	149	165	180	133	148	160	173

795.0 KCMIL, 37 STRAND, BARE AAC, "ARBUTUS" – 15 KV			
ISSUE	PAGE NUMBER	OVERHEAD CONSTRUCTION STANDARD	
7/17	6-105		

© 2022 PPL Corporation. All rights reserved. Doc. # ST.06.00.003

Std. Item:	W21BF
Item ID:	9302781 <sup>E</sup>
CU:	C795ALSTBRNE

FINAL SAG TABLE								
TEMP. °F	LOADING (UNLOADED CONDITIONS)							
	0	32	60	90	120	158	176	194
TEMP. °C	-18	0	15	32	50	70	80	90
	Unloaded	Unloaded	Unloaded	Unloaded	Unloaded	Unloaded	Unloaded	Unloaded
DEAD END SPAN (FEET)								
50	1.92	5.64	5.86	8.88	11.28	13.44	15.60	16.56
75	6.00	11.16	11.43	15.24	18.60	21.48	24.60	26.04
100	12.84	18.60	18.91	23.28	27.24	30.72	34.68	36.48
125	21.96	27.84	28.18	33.00	37.44	41.40	46.08	48.12
150	33.00	39.12	39.48	44.52	49.32	53.76	58.92	61.20
175	46.08	52.20	52.58	57.84	63.00	67.80	73.44	75.96
200	61.08	67.32	67.71	73.20	78.48	83.52	89.64	92.28
225	78.24	84.48	84.87	90.36	96.00	101.28	107.52	110.40
250	97.32	103.68	104.08	109.68	115.32	120.72	127.32	130.32
275	118.44	124.80	125.21	130.92	136.68	142.32	149.04	152.16
300	141.60	147.96	148.38	154.20	160.08	165.72	172.80	175.92

FINAL SAG TABLE				
TEMP. °F	LOADING (LOADED CONDITIONS)			TENSION (LBS.)
	0	32	60	0
TEMP. °C	-18	0	15	-18
	4 LB. WIND, ½" ICE	½" ICE	6 LB. WIND	4 LB. WIND, ½" ICE
DEAD END SPAN (FEET)				
50	4.08	6.84	9.00	*1948
75	9.36	12.84	15.48	*1921
100	16.56	20.64	23.52	*1924
125	25.80	30.12	33.24	*1935
150	36.96	41.64	44.76	*1945
175	50.04	54.84	58.20	*1954
200	65.16	70.20	73.56	*1962
225	82.20	87.36	90.72	*1968
250	101.40	106.56	110.04	*1973
275	122.52	127.80	131.28	*1977
300	145.68	151.08	154.56	*1980

\* Note: Design Specification Constraint

795.0 KCMIL, 37 STRAND, BARE AAC, "ARBUTUS" – 15 kV			
	OVERHEAD CONSTRUCTION STANDARD	PAGE NUMBER	ISSUE
		6-106	7/17

© 2022 PPL Corporation. All rights reserved.

Doc. # ST.06.00.003

Std. Item:	W21ND
Item ID:	9313225
CU:	C795ALTWHP35KNE
CU:	C795ALSCHMP35KNE

PHYSICAL PROPERTIES		LOADING PROPERTIES		ELECTRICAL PROPERTIES		
R.B.S.	13,480 lbs.	TRANSVERSE	0.857 Lb/Ft	SUMMER (37.7°C)	MAXIMUM AMPACITY	WINTER (10°C)
C.S.A.	0.6245 sq. in.	VERTICAL	2.603 Lb/Ft			
R. (@ 25°C)	0.0227 Ω / 1000'	TOTAL	3.041 Lb/Ft	669	NORMAL	952
R. (@ 75°C)	0.0271 Ω / 1000'			828	EMERGENCY	1058
TEMP. LIMIT	167°F (75°C) / 194°F (90°C)	SWING	30.87°			
CONDUCTOR DIAMETER	0.932"					
COMPLETE DIAMETER	1.572" (Nominal)					
WEIGHT	1,315 lbs / 1000'					

INITIAL SAG TABLE																
TEMP. °F	RULING SPAN (FEET)															
	125				150				175				200			
	0	32	60	90	0	32	60	90	0	32	60	90	0	32	60	90
TEMP. °C	-18	0	15	32	-18	0	15	32	-18	0	15	32	-18	0	15	32
TENSION (LBS.)	942	827	752	691	917	837	781	732	903	844	801	761	894	849	814	782
ACTUAL SPAN (FEET)																
50	5	6	7	7	5	6	6	7	5	6	6	7	6	6	6	6
60	8	9	9	10	8	9	9	10	8	8	9	9	8	8	9	9
70	10	12	13	14	11	12	12	13	11	12	12	13	11	11	12	12
80	13	15	17	18	14	15	16	17	14	15	16	17	14	15	16	16
90	17	19	21	23	17	19	21	22	18	19	20	21	18	19	20	21
100	21	24	26	29	22	24	25	27	22	23	25	26	22	23	24	25
110	25	29	32	35	26	29	31	33	27	28	30	32	27	28	30	31
120	30	34	38	41	31	34	36	39	32	34	36	38	32	34	35	37
130	35	40	44	48	36	40	43	46	37	40	42	44	38	40	41	43
140	41	47	51	56	42	46	50	53	43	46	49	51	44	46	48	50
150	47	54	59	64	48	53	57	61	49	53	56	59	50	53	55	57
160	54	61	67	73	55	61	65	69	56	60	63	67	57	60	62	65
170	61	69	76	83	62	68	73	78	63	68	72	75	64	68	70	73
180	68	77	85	93	70	77	82	88	71	76	80	84	72	76	79	82
190	76	86	95	103	78	85	91	98	79	85	89	94	80	84	88	92
200	84	96	105	115	86	95	101	108	88	94	99	104	89	94	98	102
210	92	105	116	126	95	104	112	119	97	104	109	115	98	103	108	112
220	101	116	127	139	104	114	123	131	106	114	120	126	107	113	118	123
230	111	126	139	152	114	125	134	143	116	124	131	138	117	124	129	134
240	121	138	151	165	124	136	146	156	126	135	143	150	128	135	140	146
250	131	149	164	179	135	148	158	169	137	147	155	163	139	146	152	159
260	142	162	178	194	146	160	171	183	148	159	167	176	150	158	165	172
270	153	174	191	209	157	172	185	198	160	171	181	190	162	170	178	185
280	164	187	206	225	169	185	199	212	172	184	194	204	174	183	191	199
290	176	201	221	241	181	199	213	228	185	198	208	219	187	197	205	214
300	189	215	236	258	194	213	228	244	197	211	223	235	200	210	220	229

795.0 KCMIL, 19 STRAND, COMPACT AAC, 320 MIL COVERED TREE WIRE – 35 kV

ISSUE	PAGE NUMBER	OVERHEAD CONSTRUCTION STANDARD	
7/17	6-107		

© 2022 PPL Corporation. All rights reserved.

Doc. # ST.06.00.003

Std. Item:	W21ND
Item ID:	9313225
CU:	C795ALTWHMP35KNE
CU:	C795ALSCHMP35KNE

FINAL SAG TABLE								
TEMP. °F	LOADING (UNLOADED CONDITIONS)							
	0	32	60	90	120	158	176	194
TEMP. °C	-18	0	15	32	50	70	80	90
	Unloaded	Unloaded	Unloaded	Unloaded	Unloaded	Unloaded	Unloaded	Unloaded
DEAD END SPAN (FEET)								
50	3.84	7.20	7.38	9.96	12.24	14.16	16.32	17.16
75	10.56	14.64	14.86	18.00	20.88	23.40	26.40	27.60
100	20.88	25.08	25.33	28.80	32.04	35.04	38.64	40.20
125	34.08	38.28	38.54	42.24	45.84	49.20	53.16	54.84
150	50.04	54.36	54.62	58.32	62.16	65.76	70.08	72.00
175	68.76	73.20	73.47	77.28	81.24	85.08	89.64	91.68
200	90.48	94.92	95.20	99.12	103.20	107.16	111.84	114.12
225	115.08	119.52	119.81	123.84	128.04	132.00	136.92	139.20
250	142.68	147.12	147.41	151.44	155.76	159.84	164.88	167.28
275	173.28	177.72	178.02	182.16	186.36	190.56	195.72	198.12
300	206.88	211.44	211.73	215.76	220.08	224.28	229.56	232.08

FINAL SAG TABLE				
TEMP. °F	LOADING (LOADED CONDITIONS)			TENSION (LBS.)
	0	32	60	0
TEMP. °C	-18	0	15	-18
	4 LB. WIND, ½" ICE	½" ICE	6 LB. WIND	4 LB. WIND, ½" ICE
DEAD END SPAN (FEET)				
50	5.76	8.28	10.08	*2000
75	12.84	15.96	18.12	*2000
100	23.16	26.64	28.92	*1973
125	36.36	39.96	42.36	*1967
150	52.32	56.16	58.56	*1969
175	71.16	75.00	77.52	*1973
200	92.88	96.84	99.36	*1977
225	117.48	121.44	124.08	*1981
250	145.08	149.16	151.80	*1984
275	175.68	179.76	182.40	*1986
300	209.28	213.36	216.12	*1988

\* Note: Design Specification Constraint

795.0 KCMIL, 19 STRAND, COMPACT AAC, 320 MIL COVERED TREE WIRE – 35 kV

	OVERHEAD CONSTRUCTION STANDARD	PAGE NUMBER	ISSUE
		6-108	7/17

© 2022 PPL Corporation. All rights reserved.

Doc. # ST.06.00.003

Std. Item:	W21BG
Item ID:	9313226
CU:	C795ALTWHMPNE
CU:	C795ALSCHMPNE

PHYSICAL PROPERTIES		LOADING PROPERTIES		ELECTRICAL PROPERTIES		
R.B.S.	13,480 lbs.	TRANSVERSE	0.764 Lb/Ft	SUMMER (37.7°C)	MAXIMUM AMPACITY	WINTER (10°C)
C.S.A.	0.6245 sq. in.	VERTICAL	2.163 Lb/Ft			
R. (@ 25°C)	0.0227 Ω / 1000'	TOTAL	2.594 Lb/Ft	714	NORMAL	1005
R. (@ 75°C)	0.0271 Ω / 1000'			881	EMERGENCY	1118
TEMP. LIMIT	167°F (75°C) / 194°F (90°C)	SWING	31.63°			
CONDUCTOR DIAMETER	0.932"					
COMPLETE DIAMETER	1.292" (Nominal)					
WEIGHT	1,049 lbs / 1000'					

INITIAL SAG TABLE																
TEMP. °F	RULING SPAN (FEET)															
	125				150				175				200			
	0	32	60	90	0	32	60	90	0	32	60	90	0	32	60	90
TEMP. °C	-18	0	15	32	-18	0	15	32	-18	0	15	32	-18	0	15	32
TENSION (LBS.)	916	766	677	609	881	777	709	653	861	785	731	685	848	790	747	708
ACTUAL SPAN (FEET)																
50	4	5	6	6	4	5	6	6	5	5	5	6	5	5	5	6
60	6	7	8	9	6	7	8	9	7	7	8	8	7	7	8	8
70	8	10	11	13	9	10	11	12	9	10	11	11	9	10	10	11
80	11	13	15	17	11	13	14	15	12	13	14	15	12	13	14	14
90	14	17	19	21	14	16	18	20	15	16	17	19	15	16	17	18
100	17	21	23	26	18	20	22	24	18	20	22	23	19	20	21	22
110	21	25	28	31	22	25	27	29	22	24	26	28	23	24	26	27
120	25	30	34	37	26	29	32	35	26	29	31	33	27	29	30	32
130	29	35	39	44	30	34	38	41	31	34	36	39	31	34	36	38
140	34	40	46	51	35	40	44	47	36	39	42	45	37	39	41	44
150	39	46	52	58	40	46	50	54	41	45	49	52	42	45	48	50
160	44	53	60	66	46	52	57	62	47	52	55	59	48	51	54	57
170	50	60	67	75	52	59	64	70	53	58	62	67	54	58	61	65
180	56	67	75	84	58	66	72	78	59	65	70	75	60	65	69	72
190	62	74	84	93	64	73	80	87	66	73	78	83	67	72	76	81
200	69	82	93	104	71	81	89	97	73	81	86	92	75	80	85	89
210	76	91	103	114	79	90	98	107	81	89	95	102	82	88	93	98
220	83	100	113	125	86	98	108	117	89	97	104	112	90	97	102	108
230	91	109	123	137	95	107	118	128	97	106	114	122	99	106	112	118
240	99	119	134	149	103	117	128	139	106	116	124	133	107	115	122	129
250	108	129	145	162	112	127	139	151	115	126	135	144	116	125	132	140
260	116	139	157	175	121	137	150	164	124	136	146	156	126	135	143	151
270	125	150	170	189	130	148	162	177	134	147	157	168	136	146	154	163
280	135	162	182	203	140	159	174	190	144	158	169	181	146	157	166	175
290	145	173	196	218	150	171	187	204	154	169	182	194	157	168	178	188
300	155	186	209	233	161	183	200	218	165	181	194	208	168	180	190	201

795.0 KCMIL, 19 STRAND, COMPACT AAC, 180 MIL COVERED TREE WIRE – 15 KV

ISSUE	PAGE NUMBER	OVERHEAD CONSTRUCTION STANDARD	
7/17	6-109		

© 2022 PPL Corporation. All rights reserved.

Doc. # ST.06.00.003

Std. Item:	W21BG
Item ID:	9313226
CU:	C795ALTWHMPNE
CU:	C795ALSCHMPNE

FINAL SAG TABLE								
TEMP. °F	LOADING (UNLOADED CONDITIONS)							
	0	32	60	90	120	158	176	194
TEMP. °C	-18	0	15	32	50	70	80	90
	Unloaded	Unloaded	Unloaded	Unloaded	Unloaded	Unloaded	Unloaded	Unloaded
DEAD END SPAN (FEET)								
50	2.88	6.48	6.68	9.48	11.76	13.80	15.96	16.92
75	8.28	12.84	13.09	16.56	19.68	22.32	25.44	26.76
100	16.68	21.48	21.76	25.68	29.28	32.64	36.36	38.04
125	27.72	32.76	33.06	37.20	41.28	44.88	49.20	51.12
150	41.40	46.56	46.86	51.12	55.44	59.40	64.20	66.24
175	57.48	62.64	62.96	67.44	71.88	76.20	81.24	83.52
200	76.08	81.24	81.56	86.04	90.72	95.16	100.44	102.96
225	96.96	102.24	102.57	107.16	111.96	116.52	122.04	124.56
250	120.48	125.64	125.98	130.68	135.48	140.16	145.92	148.56
275	146.40	151.68	152.02	156.72	161.64	166.44	172.32	174.96
300	174.96	180.24	180.58	185.28	190.32	195.12	201.12	203.88

FINAL SAG TABLE				
TEMP. °F	LOADING (LOADED CONDITIONS)			TENSION (LBS.)
	0	32	60	0
TEMP. °C	-18	0	15	-18
	4 LB. WIND, ½" ICE	½" ICE	6 LB. WIND	4 LB. WIND, ½" ICE
DEAD END SPAN (FEET)				
50	4.92	7.56	9.48	*2000
75	10.92	14.28	16.68	*2000
100	19.44	23.28	25.92	*2000
125	30.60	34.68	37.44	*1987
150	44.28	48.60	51.48	*1980
175	60.36	64.80	67.68	*1979
200	78.96	83.40	86.40	*1981
225	99.96	104.40	107.40	*1983
250	123.36	127.92	131.04	*1985
275	149.40	153.96	157.08	*1987
300	177.84	182.52	185.64	*1988

\* Note: Design Specification Constraint

795.0 KCMIL, 19 STRAND, COMPACT AAC, 180 MIL COVERED TREE WIRE – 15 kV

	OVERHEAD CONSTRUCTION STANDARD	PAGE NUMBER	ISSUE
		6-110	7/17

© 2022 PPL Corporation. All rights reserved.

Doc. # ST.06.00.003

Std. Item:	
Item ID:	9302780
CU:	C477BACSR

PHYSICAL PROPERTIES		LOADING PROPERTIES		ELECTRICAL PROPERTIES		
R.B.S.	19,500 lbs.	TRANSVERSE	0.6174 Lb/Ft	SUMMER (37.7°C)	MAXIMUM AMPACITY	WINTER (10°C)
C.S.A.	0.4353 sq. in.	VERTICAL	1.501 Lb/Ft			
R. (@ 25°C)	0.0366 Ω / 1000'	TOTAL	1.923 Lb/Ft	658	NORMAL	938
R. (@ 75°C)	0.0438 Ω / 1000'			742	EMERGENCY	991
TEMP. LIMIT	176°F (80°C) / 194°F (90°C)	SWING	33.18°			
CONDUCTOR DIAMETER	0.858" (Nominal)					
WEIGHT	656 lbs / 1000'					

INITIAL SAG TABLE																
TEMP. °F	RULING SPAN (FEET)															
	125				150				175				200			
	0	32	60	90	0	32	60	90	0	32	60	90	0	32	60	90
TEMP. °C	-18	0	15	32	-18	0	15	32	-18	0	15	32	-18	0	15	32
TENSION (LBS.)	2200	1333	913	691	1936	1255	937	750	1707	1200	954	796	1533	1161	967	832
ACTUAL SPAN (FEET)																
50	1	2	3	4	1	2	3	3	1	2	3	3	2	2	3	3
60	2	3	4	5	2	3	4	5	2	3	4	4	2	3	4	4
70	2	4	5	7	2	4	5	6	3	4	5	6	3	4	5	6
80	3	5	7	9	3	5	7	8	4	5	7	8	4	5	7	8
90	4	6	9	12	4	6	9	11	5	7	8	10	5	7	8	10
100	4	7	11	14	5	8	11	13	6	8	10	12	6	8	10	12
110	5	9	13	17	6	9	13	16	7	10	12	15	8	10	12	14
120	6	11	16	21	7	11	15	19	8	12	15	18	9	12	15	17
130	8	12	18	24	9	13	18	22	10	14	17	21	11	14	17	20
140	9	14	21	28	10	15	21	26	11	16	20	24	13	17	20	23
150	10	17	24	32	11	18	24	30	13	18	23	28	14	19	23	27
160	11	19	28	36	13	20	27	34	15	21	26	32	16	22	26	30
170	13	21	31	41	15	23	30	38	17	24	30	36	19	25	29	34
180	14	24	35	46	16	25	34	43	19	27	33	40	21	27	33	38
190	16	27	39	51	18	28	38	47	21	30	37	45	23	31	37	43
200	18	30	43	57	20	31	42	53	23	33	41	50	26	34	41	47
210	20	33	48	63	22	35	46	58	25	36	45	55	28	37	45	52
220	22	36	52	69	25	38	51	64	28	40	50	60	31	41	49	57
230	24	39	57	75	27	41	56	69	31	43	55	65	34	45	54	63
240	26	43	62	82	29	45	61	76	33	47	59	71	37	49	59	68
250	28	46	67	89	32	49	66	82	36	51	64	77	40	53	64	74
260	30	50	73	96	34	53	71	89	39	55	70	84	43	57	69	80
270	33	54	79	104	37	57	77	96	42	60	75	90	47	62	74	86
280	35	58	85	112	40	61	82	103	45	64	81	97	50	66	80	93
290	38	62	91	120	43	66	88	111	48	69	87	104	54	71	86	100
300	40	66	97	128	46	71	95	118	52	74	93	111	58	76	92	107

\*\*\* Simulated with a maximum tension of 3000 lbs. \*\*\*

477.0 KCMIL, 26/7 STRANDING, BARE ACSR, "HAWK" – 15 kV			
ISSUE	PAGE NUMBER	OVERHEAD CONSTRUCTION STANDARD	
7/17	6-111		

© 2022 PPL Corporation. All rights reserved.

Doc. # ST.06.00.003

Std. Item:	
Item ID:	9302780
CU:	C477BACSR

FINAL SAG TABLE								
TEMP. °F	LOADING (UNLOADED CONDITIONS)							
	0	32	60	90	120	158	176	194
TEMP. °C	-18	0	15	32	50	70	80	90
	Unloaded	Unloaded	Unloaded	Unloaded	Unloaded	Unloaded	Unloaded	Unloaded
DEAD END SPAN (FEET)								
50	0.84	1.8	4.44	6.12	7.68	9.36	10.08	10.68
75	2.16	4.32	8.28	10.92	12.84	15.12	16.08	17.04
100	4.2	8.16	13.2	16.68	19.08	21.72	23.04	24.12
125	7.44	13.32	19.08	23.4	26.16	29.28	30.72	32.04
150	12.36	19.68	26.04	31.20	34.20	37.68	39.24	40.92
175	19.08	27.48	34.08	39.96	43.20	47.04	48.84	50.52
200	27.48	36.36	43.32	49.80	53.28	57.36	59.28	61.20
225	37.44	46.56	53.64	60.72	64.32	68.76	70.80	72.84
250	48.72	57.96	65.28	72.48	76.56	81.24	83.40	85.44
275	61.20	70.56	78.00	85.44	89.76	94.68	96.96	99.12
300	75.00	84.36	91.92	99.48	104.28	109.32	111.60	113.88

FINAL SAG TABLE				
TEMP. °F	LOADING (LOADED CONDITIONS)			TENSION (LBS.)
	0	32	60	0
TEMP. °C	-18	0	15	-18
	4 LB. WIND, ½" ICE	½" ICE	6 LB. WIND	4 LB. WIND, ½" ICE
DEAD END SPAN (FEET)				
50	2.40	3.48	4.68	3000*
75	5.40	7.20	8.64	3000*
100	9.60	12.00	13.68	3000*
125	15.00	18.00	19.68	3000*
150	21.60	24.96	26.64	3000*
175	29.52	33.12	34.80	3000*
200	38.52	42.48	44.16	3000*
225	48.72	52.92	54.60	3000*
250	60.12	64.44	66.12	3000*
275	72.72	77.28	78.96	3000*
300	86.64	91.20	92.88	3000*

\* Note: Design Specification Constraint

\*\*\* Simulated with a maximum tension of 3000 lbs. \*\*\*

477.0 KCMIL, 26/7 STRANDING, BARE ACSR, "HAWK" – 15 kV			
	OVERHEAD CONSTRUCTION STANDARD	PAGE NUMBER	ISSUE
		6-112	7/15

© 2022 PPL Corporation. All rights reserved.

Doc. # ST.06.00.003

Std. Item:	W21BA
Item ID:	9314655
CU:	C477ALSTBR

PHYSICAL PROPERTIES		LOADING PROPERTIES		ELECTRICAL PROPERTIES		
R.B.S.	8,360 lbs.	TRANSVERSE	0.598 Lb/Ft	SUMMER (37.7°C)	MAXIMUM AMPACITY	WINTER (10°C)
C.S.A.	0.3744 sq. in.	VERTICAL	1.251 Lb/Ft			
R. (@ 25°C)	0.0373 Ω / 1000'	TOTAL	1.686 Lb/Ft	640	NORMAL	908
R. (@ 75°C)	0.0445 Ω / 1000'			721	EMERGENCY	960
TEMP. LIMIT	176°F (80°C) / 194°F (90°C)	SWING	41.59°			
CONDUCTOR DIAMETER	0.792"					
WEIGHT	447 lbs / 1000'					

INITIAL SAG TABLE																
TEMP. °F	RULING SPAN (FEET)															
	125				150				175				200			
	0	32	60	90	0	32	60	90	0	32	60	90	0	32	60	90
TEMP. °C	-18	0	15	32	-18	0	15	32	-18	0	15	32	-18	0	15	32
TENSION (LBS.)	1087	622	451	363	886	593	469	394	766	576	483	419	696	566	492	438
ACTUAL SPAN (FEET)																
50	2	3	4	5	2	3	4	4	2	3	3	4	2	3	3	4
60	2	4	5	7	3	4	5	6	3	4	5	6	3	4	5	6
70	3	5	7	9	4	6	7	8	4	6	7	8	5	6	7	8
80	4	7	10	12	5	7	9	11	6	7	9	10	6	8	9	10
90	5	9	12	15	6	9	12	14	7	9	11	13	8	10	11	12
100	6	11	15	19	8	11	14	17	9	12	14	16	10	12	14	15
110	7	13	18	22	9	14	17	21	11	14	17	19	12	14	17	19
120	9	16	21	27	11	16	21	24	13	17	20	23	14	17	20	22
130	10	18	25	31	13	19	24	29	15	20	24	27	16	20	23	26
140	12	21	29	36	15	22	28	33	17	23	27	31	19	23	27	30
150	14	24	34	42	17	26	32	38	20	26	31	36	22	27	31	35
160	16	28	38	47	19	29	37	44	22	30	36	41	25	30	35	39
170	18	31	43	53	22	33	41	49	25	34	40	46	28	34	39	44
180	20	35	48	60	25	37	46	55	28	38	45	52	31	39	44	50
190	22	39	54	67	27	41	52	61	32	42	50	58	35	43	49	55
200	25	44	60	74	30	45	57	68	35	47	56	64	39	48	55	61
210	27	48	66	82	33	50	63	75	39	52	61	71	42	52	60	68
220	30	53	72	90	37	55	69	82	42	57	67	78	47	58	66	74
230	33	58	79	98	40	60	76	90	46	62	74	85	51	63	72	81
240	35	63	86	107	44	65	82	98	51	67	80	92	55	68	79	88
250	38	68	93	116	47	71	89	106	55	73	87	100	60	74	85	96
260	42	74	101	125	51	77	97	115	59	79	94	108	65	80	92	104
270	45	79	109	135	55	83	104	124	64	85	101	117	70	87	100	112
280	48	85	117	145	59	89	112	133	69	92	109	126	75	93	107	120
290	52	92	125	156	64	96	120	143	74	98	117	135	81	100	115	129
300	55	98	134	167	68	102	129	153	79	105	125	144	87	107	123	138

477.0 KCMIL, 19 STRAND, BARE AAC, "COSMOS" – 15 kV			
ISSUE	PAGE NUMBER	OVERHEAD CONSTRUCTION STANDARD	
7/17	6-113		

© 2022 PPL Corporation. All rights reserved.

Doc. # ST.06.00.003

Std. Item:	W21BA
Item ID:	9314655
CU:	C477ALSTBR

FINAL SAG TABLE								
TEMP. °F	LOADING (UNLOADED CONDITIONS)							
	0	32	60	90	120	158	176	194
TEMP. °C	-18	0	15	32	50	70	80	90
	Unloaded	Unloaded	Unloaded	Unloaded	Unloaded	Unloaded	Unloaded	Unloaded
DEAD END SPAN (FEET)								
50	0.96	2.64	2.90	6.60	9.60	11.88	14.40	15.48
75	2.52	6.24	6.59	11.52	15.48	18.84	22.32	23.88
100	5.52	11.64	12.04	17.64	22.56	26.64	31.08	33.00
125	11.16	18.72	19.15	25.20	30.72	35.40	40.68	42.96
150	19.20	27.36	27.82	34.32	40.20	45.48	51.48	54.12
175	29.40	37.68	38.16	44.88	51.24	56.88	63.48	66.36
200	41.52	49.80	50.29	57.12	63.84	69.84	76.92	80.04
225	55.20	63.48	63.98	70.92	77.76	84.12	91.56	94.92
250	70.44	78.72	79.22	86.28	93.36	99.96	107.64	111.24
275	87.24	95.52	96.03	103.20	110.40	117.12	125.28	128.88
300	105.60	113.88	114.40	121.68	129.00	135.96	144.24	148.08

FINAL SAG TABLE				
TEMP. °F	LOADING (LOADED CONDITIONS)			TENSION (LBS.)
	0	32	60	0
TEMP. °C	-18	0	15	-18
	4 LB. WIND, 1/2" ICE	1/2" ICE	6 LB. WIND	4 LB. WIND, 1/2" ICE
DEAD END SPAN (FEET)				
50	3.12	4.80	6.84	*2000
75	7.08	9.60	11.88	*2000
100	12.60	15.84	18.24	*2000
125	19.80	23.40	25.92	*2000
150	28.44	32.52	35.04	*2000
175	38.88	43.08	45.72	*1996
200	50.88	55.44	57.96	*1989
225	64.56	69.24	71.88	*1987
250	79.80	84.60	87.24	*1986
275	96.60	101.52	104.16	*1986
300	114.96	120.00	122.64	*1987

\* Note: Design Specification Constraint

477.0 KCMIL, 19 STRAND, BARE AAC, "COSMOS" – 15 kV

	OVERHEAD CONSTRUCTION STANDARD	PAGE NUMBER	ISSUE
		6-114	7/17

© 2022 PPL Corporation. All rights reserved. Doc. # ST.06.00.003

Std. Item:	W21NB
Item ID:	9313248 <sup>E</sup>
CU:	C477ALTWHMP35KNE
CU:	C477ALSCHMP35KNE

PHYSICAL PROPERTIES		LOADING PROPERTIES		ELECTRICAL PROPERTIES		
R.B.S.	8,360 lbs.	TRANSVERSE	0.787 Lb/Ft	SUMMER (37.7°C)	MAXIMUM AMPACITY	WINTER (10°C)
C.S.A.	0.3746 sq. in.	VERTICAL	2.061 Lb/Ft			
R. (@ 25°C)	0.0373 Ω / 1000'	TOTAL	2.506 Lb/Ft	489	NORMAL	692
R. (@ 75°C)	0.0447 Ω / 1000'			603	EMERGENCY	768
TEMP. LIMIT	167°F (75°C) / 194°F (90°C)	SWING	37.02°			
CONDUCTOR DIAMETER	0.722"					
COMPLETE DIAMETER	1.362" (Nominal)					
WEIGHT	903 lbs / 1000'					

INITIAL SAG TABLE																
TEMP. °F	RULING SPAN (FEET)															
	125				150				175				200			
	0	32	60	90	0	32	60	90	0	32	60	90	0	32	60	90
TEMP. °C	-18	0	15	32	-18	0	15	32	-18	0	15	32	-18	0	15	32
TENSION (LBS.)	931	749	646	572	859	740	665	605	818	735	678	630	793	732	687	647
ACTUAL SPAN (FEET)																
50	4	5	5	6	4	5	5	6	4	5	5	5	4	5	5	5
60	5	7	8	9	6	7	7	8	6	7	7	8	6	7	7	8
70	7	9	10	12	8	9	10	11	8	9	10	11	8	9	10	10
80	9	12	13	15	10	12	13	14	11	12	13	14	11	12	13	13
90	12	15	17	19	13	15	17	18	13	15	16	17	14	15	16	17
100	15	18	21	24	16	18	20	22	17	18	20	22	17	19	20	21
110	18	22	25	29	19	22	25	27	20	22	24	26	21	23	24	25
120	21	26	30	34	23	26	29	32	24	27	29	31	25	27	29	30
130	25	31	35	40	27	31	35	38	28	31	34	36	29	31	33	36
140	29	36	41	47	31	36	40	44	32	36	39	42	34	36	39	41
150	33	41	47	53	36	41	46	51	37	42	45	49	39	42	45	47
160	37	47	54	61	40	47	52	57	42	47	51	55	44	48	51	54
170	42	53	61	69	46	53	59	65	48	53	58	62	50	54	57	61
180	47	59	68	77	51	59	66	73	54	60	65	70	56	60	64	68
190	53	66	76	86	57	66	74	81	60	67	72	78	62	67	71	76
200	58	73	84	95	63	73	82	90	66	74	80	86	69	74	79	84
210	64	80	92	105	70	81	90	99	73	82	88	95	76	82	87	93
220	71	88	101	115	76	89	99	109	80	89	97	104	83	90	96	102
230	77	96	111	126	84	97	108	119	88	98	106	114	91	98	105	111
240	84	105	121	137	91	106	118	129	95	106	116	124	99	107	114	121
250	91	114	131	148	99	115	128	140	104	116	125	135	107	116	124	131
260	99	123	142	160	107	124	138	152	112	125	136	146	116	126	134	142
270	106	132	153	173	115	134	149	164	121	135	146	157	125	136	144	153
280	114	142	164	186	124	144	160	176	130	145	157	169	134	146	155	165
290	123	153	176	200	133	154	172	189	139	155	169	182	144	156	167	177
300	131	164	189	214	142	165	184	202	149	166	181	194	154	167	178	189

477.0 KCMIL, 19 STRAND, COMPACT AAC, 320 MIL COVERED TREE WIRE – 35 kV			
ISSUE	PAGE NUMBER	OVERHEAD CONSTRUCTION STANDARD	
7/17	6-115		

© 2022 PPL Corporation. All rights reserved.

Doc. # ST.06.00.003

Std. Item:	W21NB
Item ID:	9313248 <sup>E</sup>
CU:	C477ALTWHP35KNE
CU:	C477ALSCHMP35KNE

FINAL SAG TABLE								
TEMP. °F	LOADING (UNLOADED CONDITIONS)							
	0	32	60	90	120	158	176	194
TEMP. °C	-18	0	15	32	50	70	80	90
	Unloaded	Unloaded	Unloaded	Unloaded	Unloaded	Unloaded	Unloaded	Unloaded
DEAD END SPAN (FEET)								
50	2.16	4.68	4.90	7.92	10.44	12.60	15.00	15.96
75	6.84	11.16	11.42	15.00	18.24	21.12	24.24	25.68
100	15.00	19.92	20.21	24.24	27.96	31.32	35.16	36.84
125	25.80	30.96	31.26	35.52	39.60	43.44	47.76	49.68
150	39.00	44.16	44.48	48.96	53.40	57.48	62.28	64.44
175	54.48	59.76	60.09	64.68	69.36	73.68	78.84	81.12
200	72.36	77.76	78.09	82.68	87.48	92.04	97.44	99.96
225	92.64	98.04	98.38	103.08	108.00	112.68	118.32	120.96
250	115.32	120.72	121.06	125.88	130.80	135.60	141.48	144.24
275	140.40	145.80	146.14	150.96	156.00	160.92	166.92	169.80
300	167.88	173.28	173.63	178.56	183.72	188.64	194.88	197.64

FINAL SAG TABLE				
TEMP. °F	LOADING (LOADED CONDITIONS)			TENSION (LBS.)
	0	32	60	0
TEMP. °C	-18	0	15	-18
	4 LB. WIND, ½" ICE	½" ICE	6 LB. WIND	4 LB. WIND, ½" ICE
DEAD END SPAN (FEET)				
50	4.68	6.60	8.16	*2000
75	10.92	13.68	15.36	*1928
100	19.68	22.80	24.60	*1909
125	30.72	34.08	36.00	*1914
150	44.04	47.64	49.56	*1925
175	59.64	63.36	65.28	*1937
200	77.52	81.48	83.40	*1946
225	97.92	101.88	103.80	*1955
250	120.60	124.56	126.48	*1961
275	145.68	149.76	151.68	*1967
300	173.16	177.36	179.28	*1971

\* Note: Design Specification Constraint

477.0 KCMIL, 19 STRAND, COMPACT AAC, 320 MIL COVERED TREE WIRE – 35 kV

	OVERHEAD CONSTRUCTION STANDARD	PAGE NUMBER	ISSUE
		6-116	7/17

© 2022 PPL Corporation. All rights reserved.

Doc. # ST.06.00.003

Std. Item:	W21BD
Item ID:	9302808
CU:	C477ALTWHMPNE
CU:	C477ALSCHMPNE

PHYSICAL PROPERTIES		LOADING PROPERTIES		ELECTRICAL PROPERTIES		
R.B.S.	8,360 lbs.	TRANSVERSE	0.681 Lb/Ft	SUMMER (37.7°C)	MAXIMUM AMPACITY	WINTER (10°C)
C.S.A.	0.3744 sq. in.	VERTICAL	1.596 Lb/Ft			
R. (@ 25°C)	0.0373 Ω / 1000'	TOTAL	2.035 Lb/Ft	528	NORMAL	739
R. (@ 75°C)	0.0447 Ω / 1000'			647	EMERGENCY	819
TEMP. LIMIT	167°F (75°C) / 194°F (90°C)	SWING	39.28°			
CONDUCTOR DIAMETER	0.722"					
COMPLETE DIAMETER	1.042" (Nominal)					
WEIGHT	637 lbs / 1000'					

INITIAL SAG TABLE																
TEMP. °F	RULING SPAN (FEET)															
	125				150				175				200			
TEMP. °C	0	32	60	90	0	32	60	90	0	32	60	90	0	32	60	90
TENSION (LBS.)	973	679	546	462	848	664	566	496	778	654	579	521	737	647	589	541
ACTUAL SPAN (FEET)																
50	2	4	4	5	3	4	4	5	3	4	4	5	3	4	4	4
60	4	5	6	7	4	5	6	7	4	5	6	7	5	5	6	6
70	5	7	9	10	6	7	8	9	6	7	8	9	6	7	8	9
80	6	9	11	13	7	9	11	12	8	9	11	12	8	9	10	11
90	8	11	14	17	9	12	14	16	10	12	13	15	11	12	13	14
100	10	14	18	21	11	14	17	19	12	15	17	18	13	15	16	18
110	12	17	21	25	14	18	20	23	15	18	20	22	16	18	20	21
120	14	20	25	30	16	21	24	28	18	21	24	26	19	21	23	26
130	17	24	30	35	19	24	29	33	21	25	28	31	22	25	28	30
140	19	28	34	41	22	28	33	38	24	29	32	36	25	29	32	35
150	22	32	39	47	25	33	38	43	28	33	37	41	29	33	37	40
160	25	36	45	53	29	37	43	49	31	38	42	47	33	38	42	45
170	28	41	51	60	33	42	49	56	36	42	48	53	38	43	47	51
180	32	46	57	67	36	47	55	63	40	48	54	60	42	48	53	57
190	35	51	63	75	41	52	61	70	44	53	60	66	47	53	59	64
200	39	57	70	83	45	58	68	77	49	59	66	74	52	59	65	71
210	43	62	77	91	50	64	75	85	54	65	73	81	57	65	72	78
220	48	68	85	100	54	70	82	93	60	71	80	89	63	72	79	86
230	52	75	93	110	60	77	89	102	65	78	87	97	69	78	86	94
240	57	81	101	119	65	83	97	111	71	85	95	106	75	85	94	102
250	61	88	109	130	70	90	106	121	77	92	103	115	81	93	102	111
260	66	96	118	140	76	98	114	131	83	99	112	124	88	100	110	120
270	72	103	128	151	82	105	123	141	90	107	121	134	95	108	119	129
280	77	111	137	163	88	113	133	151	96	115	130	144	102	116	128	139
290	83	119	147	174	95	122	142	162	103	123	139	155	109	125	137	149
300	88	127	158	187	101	130	152	174	111	132	149	165	117	133	147	160

477.0 KCMIL, 19 STRAND, COMPACT AAC, 160 MIL COVERED TREE WIRE – 15 kV

ISSUE	PAGE NUMBER	OVERHEAD CONSTRUCTION STANDARD	
7/17	6-117		

© 2022 PPL Corporation. All rights reserved. Doc. # ST.06.00.003

Std. Item:	W21BD
Item ID:	9302808
CU:	C477ALTWHMPNE
CU:	C477ALSCHMPNE

FINAL SAG TABLE								
TEMP. °F	LOADING (UNLOADED CONDITIONS)							
	0	32	60	90	120	158	176	194
TEMP. °C	-18	0	15	32	50	70	80	90
	Unloaded	Unloaded	Unloaded	Unloaded	Unloaded	Unloaded	Unloaded	Unloaded
DEAD END SPAN (FEET)								
50	1.44	3.60	3.83	7.08	9.96	12.24	14.64	15.60
75	3.96	8.28	8.58	12.72	16.44	19.56	22.92	24.48
100	9.24	15.12	15.46	20.28	24.60	28.32	32.52	34.44
125	17.76	24.12	24.49	29.64	34.44	38.64	43.56	45.72
150	28.44	35.04	35.42	40.80	45.84	50.52	56.04	58.44
175	41.04	47.64	48.04	53.64	59.04	64.08	69.96	72.60
200	55.56	62.28	62.69	68.40	74.04	79.32	85.56	88.32
225	72.00	78.72	79.14	84.96	90.72	96.24	102.84	105.84
250	90.36	97.08	97.50	103.44	109.32	115.08	121.92	125.04
275	110.76	117.36	117.79	123.84	129.84	135.72	142.80	146.04
300	132.96	139.68	140.10	146.04	152.28	158.28	165.48	168.84

FINAL SAG TABLE				
TEMP. °F	LOADING (LOADED CONDITIONS)			TENSION (LBS.)
	0	32	60	0
TEMP. °C	-18	0	15	-18
	4 LB. WIND, ½" ICE	½" ICE	6 LB. WIND	4 LB. WIND, ½" ICE
DEAD END SPAN (FEET)				
50	3.84	5.64	7.32	*2000
75	8.64	11.16	13.20	*2000
100	15.48	18.60	20.76	*1976
125	24.48	28.08	30.24	*1954
150	35.28	39.12	41.40	*1950
175	48.00	52.08	54.36	*1952
200	62.52	66.84	69.12	*1956
225	79.08	83.40	85.68	*1961
250	97.44	101.88	104.16	*1966
275	117.84	122.28	124.56	*1970
300	140.04	144.60	147.00	*1973

\* Note: Design Specification Constraint

477.0 KCMIL, 19 STRAND, COMPACT AAC, 160 MIL COVERED TREE WIRE – 15 kV			
	OVERHEAD CONSTRUCTION STANDARD	PAGE NUMBER	ISSUE
		6-118	7/17

© 2022 PPL Corporation. All rights reserved.

Doc. # ST.06.00.003

Std. Item:	TC52
Item ID:	9315752
CU:	C33ASSTBR

PHYSICAL PROPERTIES		LOADING PROPERTIES		ELECTRICAL PROPERTIES		
R.B.S.	8,700 lbs.	TRANSVERSE	0.5617 Lb/Ft	SUMMER (37.7°C)	MAXIMUM AMPACITY	WINTER (10°C)
C.S.A.	0.2789 sq. in.	VERTICAL	1.101 Lb/Ft			
R. (@ 25°C)	0.0523 Ω / 1000'	TOTAL	1.536 Lb/Ft	519	NORMAL	733
R. (@ 75°C)	0.0625 Ω / 1000'			584	EMERGENCY	775
TEMP. LIMIT	176°F (80°C) / 194°F (90°C)	SWING	43.14°			
CONDUCTOR DIAMETER	0.684"					
WEIGHT	365 lbs / 1000'					

INITIAL SAG TABLE																
TEMP. °F	RULING SPAN (FEET)															
	125				150				175				200			
	0	32	60	90	0	32	60	90	0	32	60	90	0	32	60	90
TEMP. °C	-18	0	15	32	-18	0	15	32	-18	0	15	32	-18	0	15	32
TENSION (LBS.)	2400	1624	972	552	2449	1690	1063	643	2398	1655	1072	693	2217	1503	1001	696
ACTUAL SPAN (FEET)																
50	1	1	1	2	1	1	1	2	1	1	1	2	1	1	1	2
60	1	1	2	4	1	1	2	3	1	1	2	3	1	1	2	3
70	1	2	3	5	1	2	3	4	1	2	3	4	1	2	3	4
80	1	2	4	6	1	2	3	5	1	2	3	5	2	2	3	5
90	2	3	5	8	2	3	4	7	2	3	4	6	2	3	4	6
100	2	3	6	10	2	3	5	9	2	3	5	8	2	4	5	8
110	3	4	7	12	3	4	6	10	3	4	6	10	3	4	7	10
120	3	5	8	14	3	5	7	12	3	5	7	11	4	5	8	11
130	4	6	10	17	4	5	9	14	4	6	9	13	4	6	9	13
140	4	7	11	19	4	6	10	17	4	6	10	15	5	7	11	15
150	5	8	13	22	5	7	12	19	5	7	11	18	6	8	12	18
160	6	9	14	25	6	8	13	22	6	8	13	20	6	9	14	20
170	7	10	16	29	6	9	15	25	7	10	15	23	7	11	16	23
180	7	11	18	32	7	10	17	28	7	11	17	26	8	12	18	25
190	8	12	20	36	8	12	19	31	8	12	18	29	9	13	20	28
200	9	13	23	40	9	13	21	34	9	13	20	32	10	15	22	31
210	10	15	25	44	10	14	23	38	10	15	23	35	11	16	24	35
220	11	16	27	48	11	16	25	41	11	16	25	38	12	18	26	38
230	12	18	30	53	12	17	27	45	12	17	27	42	13	19	29	42
240	13	19	32	57	13	19	30	49	13	19	29	46	14	21	32	45
250	14	21	35	62	14	20	32	53	14	21	32	49	15	23	34	49
260	15	23	38	67	15	22	35	58	15	22	35	53	17	25	37	53
270	17	25	41	72	16	24	38	62	17	24	37	58	18	27	40	57
280	18	26	44	78	18	25	40	67	18	26	40	62	19	29	43	62
290	19	28	47	84	19	27	43	72	19	28	43	67	21	31	46	66
300	21	30	51	89	20	29	46	77	21	30	46	71	22	33	49	71

\*\*\* Simulated with a maximum tension of 3000 lbs. \*\*\*

336.4 KCMIL, 18/1 STRANDING, BARE ACSR, "MERLIN" – 15 kV			
ISSUE	PAGE NUMBER	OVERHEAD CONSTRUCTION STANDARD	
7/15	6-119		

© 2022 PPL Corporation. All rights reserved.

Doc. # ST.06.00.003

Std. Item:	TC52
Item ID:	9315752
CU:	C33ASSTBR

FINAL SAG TABLE								
TEMP. °F	LOADING (UNLOADED CONDITIONS)							
	0	32	60	90	120	158	176	194
TEMP. °C	-18	0	15	32	50	70	80	90
	Unloaded	Unloaded	Unloaded	Unloaded	Unloaded	Unloaded	Unloaded	Unloaded
DEAD END SPAN (FEET)								
50	0.60	1.20	3.24	6.96	8.40	9.84	10.44	11.04
75	1.44	2.64	6.00	10.92	13.92	15.84	16.68	17.52
100	2.52	4.56	9.12	15.12	20.04	22.32	23.40	24.48
125	3.96	6.96	12.60	19.68	25.56	29.40	30.60	31.80
150	5.64	9.72	16.44	24.36	31.32	36.84	38.16	39.60
175	8.04	13.56	21.48	30.24	37.92	45.24	46.80	48.24
200	11.64	19.32	28.44	37.80	45.96	54.96	56.76	58.44
225	16.68	26.40	36.36	46.20	54.84	64.56	67.56	69.36
250	23.16	34.80	45.36	55.56	64.68	74.88	79.08	81.00
275	31.44	44.40	55.32	65.76	75.24	86.04	90.84	93.36
300	41.40	55.08	66.24	77.04	86.76	98.04	102.96	106.68

FINAL SAG TABLE				
TEMP. °F	LOADING (LOADED CONDITIONS)			TENSION (LBS.)
	0	32	60	0
TEMP. °C	-18	0	15	-18
	4 LB. WIND, ½" ICE	½" ICE	6 LB. WIND	4 LB. WIND, ½" ICE
DEAD END SPAN (FEET)				
50	2.52	3.12	3.84	2291
75	5.40	6.36	6.84	2414
100	9.00	10.20	10.32	2553
125	13.32	14.64	14.28	2700
150	18.24	19.44	18.48	2849
175	24.00	25.32	23.88	*2936
200	31.32	32.76	31.08	*2948
225	39.48	41.04	39.12	*2958
250	48.60	50.28	48.24	*2965
275	58.68	60.48	58.20	*2971
300	69.72	71.52	69.24	*2976

\* Note: Design Specification Constraint

\*\*\* Simulated with a maximum tension of 3000 lbs. \*\*\*

336.4 KCMIL, 18/1 STRANDING, BARE ACSR, "MERLIN" – 15 kV			
	OVERHEAD CONSTRUCTION STANDARD	PAGE NUMBER	ISSUE
		6-120	7/15

© 2022 PPL Corporation. All rights reserved.

Doc. # ST.06.00.003

Std. Item:	W20B
Item ID:	9316037
CU:	C33ALSTBR

PHYSICAL PROPERTIES		LOADING PROPERTIES		ELECTRICAL PROPERTIES		
R.B.S.	6,150 lbs.	TRANSVERSE	0.555 Lb/Ft	SUMMER (37.7°C)	MAXIMUM AMPACITY	WINTER (10°C)
C.S.A.	0.2644 sq. in.	VERTICAL	1.040 Lb/Ft			
R. (@ 25°C)	0.0527 Ω / 1000'	TOTAL	1.479 Lb/Ft	514	NORMAL	725
R. (@ 75°C)	0.0629 Ω / 1000'			578	EMERGENCY	766
TEMP. LIMIT	176°F (80°C) / 194°F (90°C)	SWING	46.55°			
CONDUCTOR DIAMETER	0.666"					
WEIGHT	315 lbs / 1000'					

INITIAL SAG TABLE																
TEMP. °F	RULING SPAN (FEET)															
	125				150				175				200			
	0	32	60	90	0	32	60	90	0	32	60	90	0	32	60	90
TEMP. °C	-18	0	15	32	-18	0	15	32	-18	0	15	32	-18	0	15	32
TENSION (LBS.)	1444	827	483	333	1220	707	467	353	998	622	457	367	821	568	450	378
ACTUAL SPAN (FEET)																
50	1	1	2	4	1	2	3	3	1	2	3	3	1	2	3	3
60	1	2	4	5	1	2	4	5	2	3	4	5	2	3	4	5
70	2	3	5	7	2	3	5	7	2	4	5	6	3	4	5	6
80	2	4	6	9	2	4	6	9	3	5	7	8	4	5	7	8
90	3	5	8	12	3	5	8	11	4	6	8	10	5	7	9	10
100	3	6	10	14	4	7	10	13	5	8	10	13	6	8	11	13
110	4	7	12	17	5	8	12	16	6	9	13	16	7	10	13	15
120	5	8	14	20	6	10	15	19	7	11	15	19	8	12	15	18
130	6	10	16	24	7	11	17	23	8	13	17	22	10	14	18	21
140	6	11	19	28	8	13	20	26	9	15	20	25	11	16	21	25
150	7	13	22	32	9	15	23	30	11	17	23	29	13	19	24	28
160	8	15	25	36	10	17	26	34	12	20	26	33	15	21	27	32
170	10	17	28	41	11	20	29	39	14	22	30	37	17	24	30	36
180	11	19	32	46	13	22	33	44	15	25	34	42	19	27	34	41
190	12	21	35	51	14	24	37	49	17	28	37	47	21	30	38	45
200	13	23	39	57	16	27	41	54	19	31	41	52	23	33	42	50
210	15	26	43	63	17	30	45	59	21	34	46	57	25	37	46	55
220	16	28	47	69	19	33	49	65	23	37	50	62	28	41	51	61
230	17	31	52	75	21	36	54	71	25	40	55	68	30	44	56	66
240	19	33	56	82	22	39	58	77	27	44	60	74	33	48	60	72
250	21	36	61	89	24	42	63	84	30	48	65	81	36	52	66	78
260	22	39	66	96	26	46	69	91	32	52	70	87	39	57	71	85
270	24	42	71	104	28	49	74	98	35	56	75	94	42	61	77	91
280	26	46	76	111	31	53	79	105	37	60	81	101	45	66	82	98
290	28	49	82	119	33	57	85	113	40	64	87	108	48	70	88	105
300	30	52	88	128	35	61	91	121	43	69	93	116	52	75	95	113

336.4 KCMIL, 19 STRAND, BARE AAC, "TULIP" – 15 KV			
ISSUE	PAGE NUMBER	OVERHEAD CONSTRUCTION STANDARD	
7/17	6-121		

© 2022 PPL Corporation. All rights reserved. Doc. # ST.06.00.003

Std. Item:	W20B
Item ID:	9316037
CU:	C33ALSTBR

FINAL SAG TABLE								
TEMP. °F	LOADING (UNLOADED CONDITIONS)							
	0	32	60	90	120	158	176	194
TEMP. °C	-18	0	15	32	50	70	80	90
	Unloaded	Unloaded	Unloaded	Unloaded	Unloaded	Unloaded	Unloaded	Unloaded
DEAD END SPAN (FEET)								
50	0.72	1.80	2.04	5.40	8.76	11.16	13.80	14.88
75	1.68	3.72	4.06	8.76	13.44	17.04	20.88	22.44
100	3.12	6.36	6.79	12.84	18.60	23.28	28.20	30.24
125	5.88	11.64	12.14	19.20	25.68	31.08	36.96	39.36
150	10.56	18.72	19.27	27.00	33.96	39.96	46.56	49.44
175	18.00	27.60	28.17	36.12	43.56	50.04	57.24	60.48
200	27.84	37.92	38.51	46.80	54.48	61.32	69.12	72.60
225	39.60	49.80	50.39	58.68	66.60	73.80	82.20	85.80
250	52.92	63.00	63.60	72.00	80.16	87.60	96.36	100.20
275	67.68	77.64	78.25	86.76	95.04	102.72	111.84	115.92
300	83.88	93.72	94.33	102.84	111.24	119.16	128.52	132.84

FINAL SAG TABLE				
TEMP. °F	LOADING (LOADED CONDITIONS)			TENSION (LBS.)
	0	32	60	0
TEMP. °C	-18	0	15	-18
	4 LB. WIND, ½" ICE	½" ICE	6 LB. WIND	4 LB. WIND, ½" ICE
DEAD END SPAN (FEET)				
50	3.24	4.32	5.76	1710
75	6.72	8.16	9.48	1862
100	11.04	12.84	13.92	*2000
125	17.40	19.44	20.52	*2000
150	24.96	27.36	28.44	*2000
175	34.08	36.72	37.68	*1997
200	44.52	47.40	48.36	*1994
225	56.40	59.52	60.36	*1993
250	69.72	72.84	73.80	*1992
275	84.48	87.72	88.44	*1992
300	100.56	103.80	104.64	*1993

\* Note: Design Specification Constraint

336.4 KCMIL, 19 STRAND, BARE AAC, "TULIP" – 15 KV			
	OVERHEAD CONSTRUCTION STANDARD	PAGE NUMBER	ISSUE
		6-122	7/17

© 2022 PPL Corporation. All rights reserved. Doc. # ST.06.00.003

Std. Item:	W21C
Item ID:	9305136
CU:	

PHYSICAL PROPERTIES		LOADING PROPERTIES		ELECTRICAL PROPERTIES		
R.B.S.	6,150 lbs.	TRANSVERSE	0.646 Lb/Ft	SUMMER (37.7°C)	MAXIMUM AMPACITY	WINTER (10°C)
C.S.A.	0.2644 sq. in.	VERTICAL	1.390 Lb/Ft			
R. (@ 25°C)	0.0527 Ω / 1000'	TOTAL	1.833 Lb/Ft	425	NORMAL	593
R. (@ 75°C)	0.0629 Ω / 1000'			519	EMERGENCY	657
TEMP. LIMIT	167°F (75°C) / 194°F (90°C)	SWING	43.31°			
CONDUCTOR DIAMETER	0.607"					
COMPLETE DIAMETER	0.937" (Nominal)					
WEIGHT	497 lbs / 1000'					

INITIAL SAG TABLE																
TEMP. °F	RULING SPAN (FEET)															
	125				150				175				200			
	0	32	60	90	0	32	60	90	0	32	60	90	0	32	60	90
TEMP. °C	-18	0	15	32	-18	0	15	32	-18	0	15	32	-18	0	15	32
TENSION (LBS.)	1215	938	713	510	1231	958	739	545	1244	977	764	577	1256	994	787	608
ACTUAL SPAN (FEET)																
50	1	2	3	4	2	3	3	4	2	3	3	4	2	3	3	4
60	2	3	5	6	3	4	5	6	3	4	5	6	4	4	5	5
70	3	5	7	8	4	5	7	8	4	6	7	8	5	6	7	7
80	4	6	9	11	5	7	9	10	6	7	9	10	6	8	9	10
90	5	8	11	14	6	9	11	13	7	9	11	13	8	10	11	12
100	6	10	13	17	7	11	13	16	9	11	13	16	10	12	14	15
110	7	12	16	20	9	13	16	19	10	14	16	19	12	14	16	18
120	9	14	19	24	11	15	19	23	12	16	19	22	14	17	19	22
130	10	16	22	29	12	18	23	27	15	19	23	26	16	20	23	26
140	12	19	26	33	14	21	26	32	17	22	26	30	19	23	27	30
150	13	22	30	38	17	24	30	36	19	25	30	35	22	27	30	34
160	15	25	34	43	19	27	34	41	22	29	35	40	25	30	35	39
170	17	28	38	49	21	31	39	47	25	33	39	45	28	34	39	44
180	19	31	43	55	24	34	43	52	28	37	44	50	32	38	44	49
190	22	35	48	61	27	38	48	58	31	41	49	56	35	43	49	55
200	24	38	53	68	29	42	54	64	35	45	54	62	39	47	54	61
210	26	42	59	75	32	47	59	71	38	50	59	69	43	52	60	67
220	29	46	64	82	36	51	65	78	42	55	65	75	47	57	65	73
230	32	51	70	89	39	56	71	85	46	60	71	82	52	63	72	80
240	35	55	77	97	42	61	77	93	50	65	78	90	56	68	78	87
250	37	60	83	106	46	66	84	101	54	71	84	97	61	74	85	95
260	40	65	90	114	50	71	90	109	59	77	91	105	66	80	91	103
270	44	70	97	123	54	77	98	117	63	83	98	113	71	86	99	111
280	47	75	104	132	58	83	105	126	68	89	106	122	76	93	106	119
290	50	81	112	142	62	89	113	135	73	95	113	131	82	100	114	128
300	54	86	120	152	66	95	120	145	78	102	121	140	88	107	122	137

336.4 KCMIL, 19 STRAND, COMPACT AAC, 165 MIL COVERED TREE WIRE – 15 KV			
ISSUE	PAGE NUMBER	OVERHEAD CONSTRUCTION STANDARD	
7/21	6-123		

© 2022 PPL Corporation. All rights reserved.

Doc. # ST.06.00.003

Std. Item:	W21C
Item ID:	9305136
CU:	

FINAL SAG TABLE								
TEMP. °F	LOADING (UNLOADED CONDITIONS)							
	0	32	60	90	120	158	176	194
TEMP. °C	-18	0	15	32	50	70	80	90
	Unloaded	Unloaded	Unloaded	Unloaded	Unloaded	Unloaded	Unloaded	Unloaded
DEAD END SPAN (FEET)								
50	1.20	2.76	5.88	9.00	11.40	13.92	15.00	15.96
75	2.76	5.64	9.96	14.04	17.52	21.24	22.80	24.24
100	6.12	11.40	16.68	21.48	25.56	30.12	32.04	33.96
125	12.24	19.20	24.96	30.24	34.92	40.20	42.48	44.64
150	21.00	28.80	34.80	40.56	45.72	51.60	54.12	56.64
175	32.04	40.08	46.32	52.44	57.84	64.32	67.08	69.84
200	45.00	53.16	59.52	65.76	71.64	78.36	81.48	84.36
225	59.76	67.80	74.40	80.88	86.88	94.08	97.32	100.44
250	76.20	84.24	90.84	97.56	103.80	111.24	114.60	117.96
275	94.32	102.36	109.08	115.80	122.28	129.96	133.56	136.92
300	114.12	122.28	129.00	135.84	142.44	150.36	154.08	157.56

FINAL SAG TABLE				
TEMP. °F	LOADING (LOADED CONDITIONS)			TENSION (LBS.)
	0	32	60	0
TEMP. °C	-18	0	15	-18
	4 LB. WIND, ½" ICE	½" ICE	6 LB. WIND	4 LB. WIND, ½" ICE
DEAD END SPAN (FEET)				
50	3.84	5.16	6.36	1771
75	7.92	9.6	10.68	1955
100	14.28	16.44	17.52	1932
125	22.32	24.96	26.04	1927
150	32.04	34.92	36	1930
175	43.56	46.68	47.64	1936
200	56.64	59.88	60.84	1943
225	71.4	74.88	75.72	1950
250	87.96	91.44	92.28	1956
275	106.2	109.8	110.52	1961
300	126.12	129.72	130.56	1965

\* Note: Design Specification Constraint

336.4 KCMIL, 19 STRAND, COMPACT AAC, 165 MIL COVERED TREE WIRE – 15 kV

	<b>OVERHEAD CONSTRUCTION STANDARD</b>	PAGE NUMBER	ISSUE
		6-124	7/21

© 2022 PPL Corporation. All rights reserved. Doc. # ST.06.00.003

Std. Item:	W20A
Item ID:	9314544
CU:	C10AAACBR

PHYSICAL PROPERTIES		LOADING PROPERTIES		ELECTRICAL PROPERTIES		
R.B.S.	4,280 lbs.	TRANSVERSE	0.466 Lb/Ft	SUMMER (37.7°C)	MAXIMUM AMPACITY	WINTER (10°C)
C.S.A.	0.0968 sq. in.	VERTICAL	0.673 Lb/Ft			
R. (@ 25°C)	0.166 Ω / 1000'	TOTAL	1.119 Lb/Ft	256	NORMAL	354
R. (@ 75°C)	0.195 Ω / 1000'			286	EMERGENCY	374
TEMP. LIMIT	176°F (80°C) / 194°F (90°C)	SWING	59.98°			
CONDUCTOR DIAMETER	0.398"					
WEIGHT	115 lbs / 1000'					

INITIAL SAG TABLE																
TEMP. °F	RULING SPAN (FEET)															
	125				150				175				200			
	0	32	60	90	0	32	60	90	0	32	60	90	0	32	60	90
TEMP. °C	-18	0	15	32	-18	0	15	32	-18	0	15	32	-18	0	15	32
TENSION (LBS.)	1164	878	638	408	1173	887	650	425	1181	897	662	442	1190	907	675	459
ACTUAL SPAN (FEET)																
50	0	0	1	1	0	0	1	1	0	0	1	1	0	0	1	1
60	1	1	1	2	1	1	1	1	1	1	1	1	1	1	1	1
70	1	1	1	2	1	1	1	2	1	1	1	2	1	1	1	2
80	1	1	2	3	1	1	2	3	1	1	2	3	1	1	2	2
90	1	2	2	3	1	2	2	3	1	2	2	3	1	2	2	3
100	1	2	3	4	1	2	3	4	1	2	3	4	1	2	3	4
110	2	2	3	5	2	2	3	5	2	2	3	5	2	2	3	5
120	2	3	4	6	2	3	4	6	2	3	4	6	2	3	4	5
130	2	3	5	7	3	3	5	7	2	3	4	7	2	3	4	6
140	3	4	5	8	3	4	5	8	3	4	5	8	3	4	5	7
150	3	4	6	10	3	4	6	9	3	4	6	9	3	4	6	8
160	4	5	7	11	4	5	7	10	4	5	7	10	4	5	7	10
170	4	6	8	12	4	6	8	12	4	6	8	11	4	6	7	11
180	5	6	9	14	5	6	9	13	5	6	9	13	5	6	8	12
190	5	7	10	15	5	7	10	15	5	7	9	14	5	7	9	14
200	6	8	11	17	6	8	11	16	6	8	11	16	6	8	10	15
210	6	9	12	19	7	9	12	18	6	9	12	17	6	8	11	17
220	7	10	13	20	7	10	13	20	7	9	13	19	7	9	12	18
230	8	10	14	22	8	10	14	21	8	10	14	21	8	10	13	20
240	8	11	15	24	9	11	15	23	8	11	15	23	8	11	15	22
250	9	12	17	26	9	12	17	25	9	12	16	24	9	12	16	23
260	10	13	18	29	10	13	18	27	10	13	18	26	10	13	17	25
270	11	14	20	31	11	14	19	30	11	14	19	29	10	14	19	27
280	11	15	21	33	12	15	21	32	11	15	21	31	11	15	20	29
290	12	17	23	36	13	17	22	34	12	16	22	33	12	16	21	32
300	13	18	24	38	13	18	24	36	13	17	24	35	13	17	23	34

1/0, 7 STRAND, BARE 6201-T81 AAAC, "AZUSA" – 15 kV			
ISSUE	PAGE NUMBER	OVERHEAD CONSTRUCTION STANDARD	
7/17	6-125		

© 2022 PPL Corporation. All rights reserved.

Doc. # ST.06.00.003

Std. Item:	W20A
Item ID:	9314544
CU:	C10AAACBR

FINAL SAG TABLE								
TEMP. °F	LOADING (UNLOADED CONDITIONS)							
	0	32	60	90	120	158	176	194
TEMP. °C	-18	0	15	32	50	70	80	90
	Unloaded	Unloaded	Unloaded	Unloaded	Unloaded	Unloaded	Unloaded	Unloaded
DEAD END SPAN (FEET)								
50	0.36	0.60	0.63	1.08	3.36	7.32	10.80	12.12
75	0.96	1.32	1.39	2.40	6.12	11.40	16.32	18.36
100	1.56	2.40	2.52	4.20	9.24	15.72	22.08	24.72
125	2.52	3.60	3.78	6.36	12.60	20.16	27.96	31.08
150	3.60	5.28	5.52	8.88	16.32	24.96	33.96	37.68
175	4.92	7.08	7.39	11.76	20.28	29.88	40.20	44.40
200	6.48	9.24	9.62	14.88	24.60	35.04	46.44	51.24
225	8.16	11.64	12.08	18.24	28.92	40.32	52.92	58.20
250	10.08	14.28	14.79	21.96	33.60	45.84	59.52	65.28
275	12.24	17.16	17.74	25.92	38.40	51.48	66.12	72.36
300	15.48	21.96	22.67	32.64	46.44	60.12	75.48	81.96

FINAL SAG TABLE				
TEMP. °F	LOADING (LOADED CONDITIONS)			TENSION (LBS.)
	0	32	60	0
TEMP. °C	-18	0	15	-18
	4 LB. WIND, ½" ICE	½" ICE	6 LB. WIND	4 LB. WIND, ½" ICE
DEAD END SPAN (FEET)				
50	3.60	3.24	2.04	1155
75	7.68	6.72	4.32	1237
100	12.60	11.16	7.32	1328
125	18.48	16.20	10.68	1421
150	24.96	21.84	14.52	1514
175	32.04	27.84	18.72	1605
200	39.60	34.44	23.16	1696
225	47.64	41.28	27.96	1784
250	56.16	48.60	33.12	1870
275	65.04	56.28	38.40	1954
300	75.60	65.76	46.32	*2000

\* Note: Design Specification Constraint

1/0, 7 STRAND, BARE 6201-T81 AAAC, "AZUSA" – 15 kV

	OVERHEAD CONSTRUCTION STANDARD	PAGE NUMBER	ISSUE
		6-126	7/17

© 2022 PPL Corporation. All rights reserved. Doc. # ST.06.00.003

Std. Item:	W21NA
Item ID:	9313250 <sup>E</sup>
CU:	C1/0ALPESCNE
CU:	C10ALSCHMPNE

PHYSICAL PROPERTIES		LOADING PROPERTIES		ELECTRICAL PROPERTIES		
R.B.S.	4,280 lbs.	TRANSVERSE	0.676 Lb/Ft	SUMMER (37.7°C)	MAXIMUM AMPACITY	WINTER (10°C)
C.S.A.	0.0968 sq. in.	VERTICAL	1.374 Lb/Ft	200	NORMAL	280
R. (@ 25°C)	0.166 Ω / 1000'	TOTAL	1.831 Lb/Ft	244	EMERGENCY	310
R. (@ 75°C)	0.195 Ω / 1000'					
TEMP. LIMIT	167°F (75°C) / 194°F (90°C)	SWING	50.48°			
CONDUCTOR DIAMETER	0.398"					
COMPLETE DIAMETER	1.028" (Nominal)					
WEIGHT	424 lbs / 1000'					

INITIAL SAG TABLE																
	RULING SPAN (FEET)															
	125				150				175				200			
TEMP. °F	0	32	60	90	0	32	60	90	0	32	60	90	0	32	60	90
TEMP. °C	-18	0	15	32	-18	0	15	32	-18	0	15	32	-18	0	15	32
TENSION (LBS.)	1259	998	794	617	1273	1022	828	661	1281	1042	858	701	1168	956	801	672
ACTUAL SPAN (FEET)																
50	1	2	2	3	1	2	2	2	1	2	2	2	1	2	2	2
60	2	2	3	4	2	2	3	3	2	2	3	3	2	2	3	3
70	2	3	4	5	2	3	4	5	2	3	4	4	3	3	4	5
80	3	4	5	7	3	4	5	6	3	4	5	6	3	4	5	6
90	4	5	6	8	4	5	6	8	4	5	6	7	4	5	6	8
100	5	6	8	10	5	6	8	10	5	6	7	9	5	7	8	9
110	6	8	10	12	6	8	9	12	6	7	9	11	7	8	10	11
120	7	9	12	15	7	9	11	14	7	9	11	13	8	10	11	14
130	9	11	13	17	8	11	13	16	8	10	13	15	9	11	13	16
140	10	13	16	20	10	12	15	19	10	12	15	18	11	13	16	19
150	11	14	18	23	11	14	17	22	11	14	17	20	12	15	18	21
160	13	16	20	26	13	16	20	25	13	16	19	23	14	17	20	24
170	15	19	23	30	14	18	22	28	14	18	21	26	16	19	23	27
180	16	21	26	33	16	20	25	31	16	20	24	29	18	22	26	31
190	18	23	29	37	18	23	28	35	18	22	27	33	20	24	29	34
200	20	26	32	41	20	25	31	38	20	25	30	36	22	27	32	38
210	22	28	35	45	22	28	34	42	22	27	33	40	24	29	35	42
220	25	31	39	50	24	30	37	46	24	30	36	44	26	32	38	46
230	27	34	42	54	27	33	41	51	26	32	39	48	29	35	42	50
240	29	37	46	59	29	36	44	55	29	35	43	52	31	38	46	55
250	32	40	50	64	31	39	48	60	31	38	46	57	34	42	50	59
260	34	43	54	70	34	42	52	65	34	41	50	61	37	45	54	64
270	37	47	58	75	37	45	56	70	36	45	54	66	40	49	58	69
280	40	50	63	81	39	49	60	75	39	48	58	71	43	52	62	74
290	43	54	67	87	42	52	65	81	42	52	62	76	46	56	67	80
300	46	58	72	93	45	56	69	86	45	55	67	82	49	60	72	85

1/0, 7 STRAND, CONCENTRIC ROUND 6201-T81 AAAC, 315 MIL COVERED TREE WIRE – 35 kV			
ISSUE	PAGE NUMBER	OVERHEAD CONSTRUCTION STANDARD	
7/17	6-127		

© 2022 PPL Corporation. All rights reserved.

Doc. # ST.06.00.003

Std. Item:	W21NA
Item ID:	9313250 <sup>E</sup>
CU:	C1/0ALPESCNE
CU:	C10ALSCHMPNE

FINAL SAG TABLE								
TEMP. °F	LOADING (UNLOADED CONDITIONS)							
	0	32	60	90	120	158	176	194
TEMP. °C	-18	0	15	32	50	70	80	90
	Unloaded	Unloaded	Unloaded	Unloaded	Unloaded	Unloaded	Unloaded	Unloaded
DEAD END SPAN (FEET)								
50	1.44	2.16	2.25	3.48	5.88	8.64	11.52	12.72
75	3.36	4.68	4.84	7.08	10.56	14.04	18.12	19.80
100	6.00	8.16	8.38	11.52	15.84	20.16	25.08	27.24
125	9.24	12.36	12.65	16.68	21.72	26.76	32.64	35.16
150	13.32	17.40	17.74	22.56	28.32	33.96	40.68	43.56
175	18.24	23.16	23.56	29.16	35.52	41.76	49.20	52.44
200	26.04	32.40	32.86	39.24	46.20	52.92	60.84	64.32
225	37.68	45.12	45.62	52.68	60.00	66.96	75.12	78.84
250	52.32	60.36	60.88	68.16	75.72	82.80	91.32	95.16
275	69.48	77.76	78.30	85.80	93.36	100.56	109.32	113.16
300	89.16	97.56	98.09	105.48	113.16	120.48	129.24	133.32

FINAL SAG TABLE				
TEMP. °F	LOADING (LOADED CONDITIONS)			TENSION (LBS.)
	0	32	60	0
TEMP. °C	-18	0	15	-18
	4 LB. WIND, ½" ICE	½" ICE	6 LB. WIND	4 LB. WIND, ½" ICE
DEAD END SPAN (FEET)				
50	5.52	5.64	4.80	1252
75	11.04	11.16	9.24	1395
100	17.88	17.76	14.64	1536
125	25.68	25.20	20.76	1672
150	34.44	33.36	27.60	1800
175	43.92	42.36	35.16	1921
200	55.80	54.00	45.72	1972
225	70.20	68.16	59.40	1986
250	86.40	84.12	74.88	1995
275	104.28	102.00	92.52	*2000
300	124.20	121.80	112.20	*2000

\* Note: Design Specification Constraint

1/0, 7 STRAND, CONCENTRIC ROUND 6201-T81 AAAC,  
315 MIL COVERED TREE WIRE – 35 kV

	OVERHEAD CONSTRUCTION STANDARD	PAGE NUMBER	ISSUE
		6-128	7/17

© 2022 PPL Corporation. All rights reserved. Doc. # ST.06.00.003

Std. Item:	W20CA
Item ID:	9302832
CU:	C1/0ALHMPESTNE
CU:	C10ALSCPE1NE

PHYSICAL PROPERTIES		LOADING PROPERTIES		ELECTRICAL PROPERTIES		
R.B.S.	4,280 lbs.	TRANSVERSE	0.576 Lb/Ft	SUMMER (37.7°C)	MAXIMUM AMPACITY	WINTER (10°C)
C.S.A.	0.0968 sq. in.	VERTICAL	1.019 Lb/Ft	214	NORMAL	296
R. (@ 25°C)	0.166 Ω / 1000'	TOTAL	1.470 Lb/Ft	259	EMERGENCY	327
R. (@ 75°C)	0.195 Ω / 1000'					
TEMP. LIMIT	167°F (75°C) / 194°F (90°C)	SWING	54.99°			
CONDUCTOR DIAMETER	0.398"					
COMPLETE DIAMETER	0.728" (Nominal)					
WEIGHT	255 lbs / 1000'					

INITIAL SAG TABLE																
TEMP. °F	RULING SPAN (FEET)															
	125				150				175				200			
TEMP. °C	0	32	60	90	0	32	60	90	0	32	60	90	0	32	60	90
TENSION (LBS.)	1215	938	713	510	1231	958	739	545	1244	977	764	577	1256	994	787	608
ACTUAL SPAN (FEET)																
50	1	1	1	2	1	1	1	2	1	1	1	2	1	1	1	2
60	1	1	2	3	1	1	2	3	1	1	2	2	1	1	2	2
70	2	2	3	4	2	2	3	3	1	2	2	3	1	2	2	3
80	2	3	3	5	2	3	3	5	2	3	3	4	2	2	3	4
90	3	3	4	6	3	3	4	6	2	3	4	5	2	3	4	5
100	3	4	5	8	3	4	5	7	3	4	5	7	3	4	5	6
110	4	5	7	9	4	5	6	9	4	5	6	8	4	5	6	8
120	5	6	8	11	4	6	7	10	4	6	7	10	4	6	7	9
130	5	7	9	13	5	7	9	12	5	7	8	11	5	7	8	11
140	6	8	11	15	6	8	10	14	6	8	10	13	6	8	10	12
150	7	9	12	17	7	9	12	16	7	9	11	15	7	9	11	14
160	8	10	14	19	8	10	13	18	8	10	13	17	8	10	12	16
170	9	12	16	22	9	12	15	20	9	11	14	19	9	11	14	18
180	10	13	17	24	10	13	17	23	10	13	16	21	10	12	16	20
190	11	15	19	27	11	15	19	25	11	14	18	24	11	14	18	23
200	13	16	22	30	12	16	21	28	12	16	20	26	12	15	19	25
210	14	18	24	33	14	18	23	31	13	17	22	29	13	17	21	28
220	15	20	26	36	15	19	25	34	15	19	24	32	15	19	24	30
230	17	22	28	40	16	21	27	37	16	21	27	35	16	20	26	33
240	18	24	31	43	18	23	30	41	18	23	29	38	18	22	28	36
250	20	26	34	47	19	25	32	44	19	24	31	41	19	24	30	39
260	21	28	36	51	21	27	35	48	21	26	34	45	21	26	33	43
270	23	30	39	55	23	29	38	51	22	29	37	48	22	28	35	46
280	25	32	42	59	24	32	41	55	24	31	39	52	24	30	38	49
290	26	34	45	63	26	34	44	59	26	33	42	56	26	32	41	53
300	28	37	48	68	28	36	47	63	28	35	45	60	28	35	44	57

1/0, 7 STRAND, CONCENTRIC ROUND 6201-T81 AAAC, 165 MIL COVERED TREE WIRE – 15 KV			
ISSUE	PAGE NUMBER	OVERHEAD CONSTRUCTION STANDARD	
7/17	6-129		

© 2022 PPL Corporation. All rights reserved.

Doc. # ST.06.00.003

Std. Item:	W20CA
Item ID:	9302830
CU:	C1/0ALHMPESTNE
CU:	C10ALSCE1NE

FINAL SAG TABLE								
TEMP. °F	LOADING (UNLOADED CONDITIONS)							
	0	32	60	90	120	158	176	194
TEMP. °C	-18	0	15	32	50	70	80	90
	Unloaded	Unloaded	Unloaded	Unloaded	Unloaded	Unloaded	Unloaded	Unloaded
DEAD END SPAN (FEET)								
50	0.84	1.32	1.38	2.28	4.80	7.92	11.16	12.36
75	2.04	2.88	3.01	4.80	8.52	12.72	17.16	18.96
100	3.60	5.04	5.24	8.04	12.84	17.88	23.52	25.80
125	5.64	7.80	8.07	11.88	17.52	23.40	30.12	32.88
150	8.04	11.16	11.49	16.08	22.68	29.40	37.08	40.32
175	10.92	14.88	15.28	20.88	28.32	35.64	44.28	48.00
200	14.28	19.20	19.66	26.16	34.20	42.36	51.84	55.92
225	18.24	24.12	24.64	31.92	40.80	49.56	59.76	64.32
250	25.80	33.72	34.34	42.96	52.56	61.68	72.24	77.04
275	36.96	46.68	47.36	56.88	66.72	75.96	86.88	91.68
300	51.00	61.92	62.62	72.48	82.44	91.80	102.84	107.88

FINAL SAG TABLE				
TEMP. °F	LOADING (LOADED CONDITIONS)			TENSION (LBS.)
	0	32	60	0
TEMP. °C	-18	0	15	-18
	4 LB. WIND, ½" ICE	½" ICE	6 LB. WIND	4 LB. WIND, ½" ICE
DEAD END SPAN (FEET)				
50	4.56	4.56	3.60	1202
75	9.48	9.12	7.08	1317
100	15.36	14.64	11.40	1436
125	22.20	21.00	16.32	1553
150	29.76	27.96	21.72	1668
175	38.04	35.52	27.72	1778
200	46.92	43.68	34.08	1885
225	56.40	52.32	41.04	1984
250	69.00	64.56	52.44	*2000
275	83.64	78.84	66.36	*2000
300	99.48	94.44	81.72	*2000

\* Note: Design Specification Constraint

1/0, 7 STRAND, CONCENTRIC ROUND 6201-T81 AAAC,  
165 MIL COVERED TREE WIRE – 15 kV

	OVERHEAD CONSTRUCTION STANDARD	PAGE NUMBER	ISSUE
		6-130	7/17

© 2022 PPL Corporation. All rights reserved.	Doc. # ST. 06.00.004
----------------------------------------------	----------------------

# Non-Standard Overhead Distribution Conductors

## *Maintenance Only*

NON – STANDARD OVERHEAD DISTRIBUTION CONDUCTORS MAINTENANCE ONLY			
<b>ISSUE</b>	<b>PAGE NUMBER</b>	<b>OVERHEAD CONSTRUCTION STANDARD</b>	
<b>1/07</b>	<b>6-200</b>		

© 2022 PPL Corporation. All rights reserved. Doc. # ST. 06.00.004

Std. Item:	
Item ID:	9302815 <sup>E</sup>
CU:	

PHYSICAL PROPERTIES		LOADING PROPERTIES		ELECTRICAL PROPERTIES		
R.B.S.	11400 lbs.	TRANSVERSE	0.6387 Lb/Ft	SUMMER (37.7°C)	MAXIMUM AMPACITY	WINTER (10°C)
C.S.A.	0.4995 sq. in.	VERTICAL	1.479 Lb/Ft	766	NORMAL	1095
R. (@ 25°C)	0.0282 Ω / 1000'	TOTAL	1.911 Lb/Ft	866	EMERGENCY	1159
R. (@ 75°C)	0.0335 Ω / 1000'					
TEMP. LIMIT	176°F (80°C) / 194°F (90°C)	SWING	37.55°			
CONDUCTOR DIAMETER	0.918"					
WEIGHT	597 lbs / 1000'					

FINAL SAG TABLE								
TEMP. °F	LOADING (UNLOADED CONDITIONS)							
	0	32	60	90	120	158	176	194
TEMP. °C	-18	0	15	32	50	70	80	90
	Unloaded	Unloaded	Unloaded	Unloaded	Unloaded	Unloaded	Unloaded	Unloaded
DEAD END SPAN (FEET)								
50	1.32	4.44	7.80	10.56	12.72	15.12	16.08	17.04
75	4.08	9.48	13.68	17.28	20.28	23.64	25.08	26.40
100	9.48	16.20	21.00	25.32	29.04	33.12	34.92	36.72
125	17.52	24.60	29.76	34.68	38.88	43.80	45.96	48.00
150	27.36	34.68	40.20	45.48	50.28	55.68	58.20	60.48
175	39.12	46.56	52.32	57.84	63.00	69.00	71.64	74.28
200	52.68	60.12	66.00	71.88	77.40	83.76	86.64	89.52
225	67.92	75.48	81.60	87.60	93.36	100.08	103.20	106.20
250	85.08	92.64	98.76	105.00	111.00	118.08	121.32	124.44
275	103.92	111.48	117.84	124.20	130.32	137.64	141.00	144.36
300	124.68	132.24	138.60	145.08	151.32	158.88	162.36	165.84

FINAL SAG TABLE				
TEMP. °F	LOADING (LOADED CONDITIONS)			TENSION (LBS.)
	0	32	60	0
TEMP. °C	-20	0	15	-20
	4 LB. WIND, ½" ICE	½" ICE	6 LB. WIND	4 LB. WIND, ½" ICE
DEAD END SPAN (FEET)				
50	3.60	5.88	8.04	*1994
75	8.28	11.40	13.92	*1947
100	14.76	18.60	21.24	*1936
125	23.16	27.36	30.12	*1939
150	33.12	37.68	40.68	*1945
175	45.00	49.68	52.80	*1953
200	58.56	63.48	66.60	*1959
225	73.92	78.96	82.08	*1965
250	91.08	96.24	99.36	*1970
275	110.04	115.20	118.44	*1974
300	130.68	135.96	139.20	*1977

\* Note: Design Specification Constraint

636.0 KCMIL, 37 STRAND, BARE AAC, "ORCHID" MAINTENANCE ONLY			
	OVERHEAD CONSTRUCTION STANDARD	PAGE NUMBER	ISSUE
		6-201	7/15

© 2022 PPL Corporation. All rights reserved. Doc. # ST. 06.00.004

Std. Item:	
Item ID:	9302815 <sup>E</sup>
CU:	C636ALSTPENE

PHYSICAL PROPERTIES		LOADING PROPERTIES		ELECTRICAL PROPERTIES		
R.B.S.	11,400 lbs.	TRANSVERSE	0.7022 Lb/Ft	SUMMER (37.7°C)	MAXIMUM AMPACITY	WINTER (10°C)
C.S.A.	0.5278 sq. in.	VERTICAL	1.745 Lb/Ft			
R. (@ 25°C)	0.0282 Ω / 1000'	TOTAL	2.181 Lb/Ft	627	NORMAL	985
R. (@ 75°C)	0.0335 Ω / 1000'			777	EMERGENCY	1072
TEMP. LIMIT	167°F (75°C) / 194°F (90°C)	SWING	36.64°			
CONDUCTOR DIAMETER	0.918"					
COMPLETE DIAMETER	1.108"					
WEIGHT	745 lbs / 1000'					

FINAL SAG TABLE								
TEMP. °F	LOADING (UNLOADED CONDITIONS)							
	0	32	60	90	120	158	176	194
	TEMP. °C	-18	0	15	32	50	70	80
DEAD END SPAN (FEET)	Unloaded	Unloaded	Unloaded	Unloaded	Unloaded	Unloaded	Unloaded	Unloaded
50	1.92	5.40	8.52	11.04	13.08	15.36	16.32	17.28
75	5.76	11.04	14.88	18.24	21.12	24.36	25.68	27.00
100	12.72	18.72	23.04	27.00	30.48	34.44	36.24	37.92
125	21.96	28.20	32.88	37.32	41.40	45.96	48.00	49.92
150	33.24	39.72	44.64	49.44	53.88	59.04	61.32	63.48
175	46.68	53.16	58.32	63.36	68.16	73.68	76.20	78.72
200	62.16	68.64	73.92	79.20	84.24	90.24	92.88	95.52
225	79.56	86.16	91.56	97.08	102.24	108.48	111.36	114.12
250	99.12	105.72	111.24	116.76	122.16	128.64	131.64	134.52
275	120.60	127.32	132.84	138.60	144.12	150.84	153.84	156.96
300	144.24	150.96	156.60	162.36	168.00	174.84	178.08	181.20

FINAL SAG TABLE				
TEMP. °F	LOADING (LOADED CONDITIONS)			TENSION (LBS.)
	0	32	60	0
	TEMP. °C	-20	0	15
DEAD END SPAN (FEET)	4 LB. WIND, ½" ICE	½" ICE	6 LB. WIND	4 LB. WIND, ½" ICE
50	4.20	6.60	8.64	*1955
75	9.60	12.72	15.12	*1924
100	17.04	20.76	23.28	*1924
125	26.40	30.48	33.24	*1934
150	37.92	42.24	45.00	*1944
175	51.36	55.92	58.68	*1953
200	66.84	71.52	74.40	*1961
225	84.36	89.16	92.04	*1967
250	103.92	108.72	111.72	*1972
275	125.52	130.44	133.44	*1976
300	149.16	154.08	157.08	*1979

\* Note: Design Specification Constraint

636.0 KCMIL, 37 STRAND, AAC, 95 MIL HDPE COVERING, "TANGERINE" MAINTENANCE ONLY			
ISSUE	PAGE NUMBER	OVERHEAD CONSTRUCTION STANDARD	
7/15	6-202		

© 2022 PPL Corporation. All rights reserved. Doc. # ST. 06.00.004

PHYSICAL PROPERTIES		LOADING PROPERTIES		ELECTRICAL PROPERTIES		
R.B.S.	5535 lbs.	TRANSVERSE	0.6693 Lb/Ft	SUMMER (37.7°C)	MAXIMUM AMPACITY	WINTER (10°C)
C.S.A.	0.3552 sq. in.	VERTICAL	1.450 Lb/Ft			
R. (@ 25°C)	0.0528 Ω / 1000'	TOTAL	1.897 Lb/Ft	396	NORMAL	626
R. (@ 75°C)	0.0630 Ω / 1000'			490	EMERGENCY	680
TEMP. LIMIT	167°F (75°C) / 194°F (90°C)	SWING	44.44°			
CONDUCTOR DIAMETER	0.666"					
COMPLETE DIAMETER	1.006"					
WEIGHT	513 lbs / 1000'					

FINAL SAG TABLE								
TEMP. °F	LOADING (UNLOADED CONDITIONS)							
	0	32	60	90	120	158	176	194
TEMP. °C	-18	0	15	32	50	70	80	90
	Unloaded	Unloaded	Unloaded	Unloaded	Unloaded	Unloaded	Unloaded	Unloaded
DEAD END SPAN (FEET)								
50	1.44	4.20	7.56	10.32	12.48	14.88	15.84	16.80
75	3.12	7.56	12.00	15.96	19.08	22.56	24.12	25.44
100	6.96	13.44	18.60	23.28	27.24	31.56	33.48	35.28
125	13.92	21.48	27.00	32.16	36.72	41.88	44.04	46.20
150	23.76	31.44	37.32	42.84	47.88	53.52	56.04	58.44
175	35.40	43.32	49.32	55.20	60.48	66.72	69.48	72.12
200	48.96	56.76	63.00	69.00	74.64	81.24	84.24	87.12
225	64.20	72.12	78.36	84.60	90.48	97.44	100.56	103.68
250	81.24	89.04	95.52	101.88	108.00	115.20	118.56	121.68
275	100.08	107.88	114.36	120.84	127.08	134.64	138.00	141.36
300	120.60	128.52	135.00	141.60	147.96	155.76	159.24	162.72

FINAL SAG TABLE				
TEMP. °F	LOADING (LOADED CONDITIONS)			TENSION (LBS.)
	0	32	60	0
TEMP. °C	-20	0	15	-20
	4 LB. WIND, ½" ICE	½" ICE	6 LB. WIND	4 LB. WIND, ½" ICE
DEAD END SPAN (FEET)				
50	4.08	6.00	7.80	1733
75	8.16	10.56	12.48	1969
100	14.28	17.28	19.32	*2000
125	22.32	25.68	27.84	*1995
150	32.28	36.12	38.16	*1981
175	44.16	48.12	50.28	*1976
200	57.60	61.80	63.96	*1976
225	72.96	77.28	79.44	*1977
250	90.00	94.32	96.60	*1978
275	108.84	113.28	115.44	*1980
300	129.36	133.92	136.08	*1982

\* Note: Design Specification Constraint

336.4 KCMIL, 19 STRAND, AAC, 170 MIL HDPE COVERING, "ANONA" MAINTENANCE ONLY			
	OVERHEAD CONSTRUCTION STANDARD	PAGE NUMBER	ISSUE
		6-203	7/15

PHYSICAL PROPERTIES		LOADING PROPERTIES		ELECTRICAL PROPERTIES		
R.B.S.	5790 lbs.	TRANSVERSE	0.6084 Lb/Ft	SUMMER (37.7°C)	MAXIMUM AMPACITY	WINTER (10°C)
C.S.A.	0.2845 sq. in.	VERTICAL	1.242 Lb/Ft			
R. (@ 25°C)	0.0528 Ω / 1000'	TOTAL	1.683 Lb/Ft	432	NORMAL	665
R. (@ 75°C)	0.0630 Ω / 1000'			530	EMERGENCY	723
TEMP. LIMIT	167°F (75°C) / 194°F (90°C)	SWING	44.72°			
CONDUCTOR DIAMETER	0.666"					
COMPLETE DIAMETER	0.826"					
WEIGHT	417 lbs / 1000'					

FINAL SAG TABLE								
TEMP. °F	LOADING (UNLOADED CONDITIONS)							
	0	32	60	90	120	158	176	194
TEMP. °C	-18	0	15	32	50	70	80	90
	Unloaded	Unloaded	Unloaded	Unloaded	Unloaded	Unloaded	Unloaded	Unloaded
DEAD END SPAN (FEET)								
50	1.08	2.88	6.36	9.36	11.76	14.28	15.24	16.32
75	2.40	5.64	10.32	14.52	18.00	21.60	23.16	24.60
100	4.68	9.72	15.36	20.52	24.84	29.52	31.56	33.48
125	9.36	16.80	23.04	28.80	33.72	39.12	41.52	43.80
150	16.92	25.56	32.16	38.28	43.68	49.80	52.56	55.08
175	27.00	35.88	42.72	49.20	55.08	61.80	64.68	67.56
200	38.88	47.88	54.84	61.68	67.80	75.00	78.12	81.24
225	52.32	61.32	68.52	75.48	81.96	89.52	92.88	96.24
250	67.44	76.44	83.64	90.84	97.56	105.48	109.08	112.44
275	84.12	93.12	100.44	107.76	114.60	122.88	126.60	130.20
300	102.36	111.36	118.68	126.12	133.20	141.72	145.56	149.28

FINAL SAG TABLE				
TEMP. °F	LOADING (LOADED CONDITIONS)			TENSION (LBS.)
	0	32	60	0
TEMP. °C	-20	0	15	-20
	4 LB. WIND, ½" ICE	½" ICE	6 LB. WIND	4 LB. WIND, ½" ICE
DEAD END SPAN (FEET)				
50	3.72	5.16	6.72	1688
75	7.56	9.48	10.92	1876
100	12.60	14.88	16.32	*1995
125	19.92	22.68	24.12	*1975
150	28.92	31.92	33.24	*1967
175	39.36	42.60	44.04	*1965
200	51.36	54.84	56.16	*1966
225	64.92	68.52	69.84	*1969
250	80.16	83.76	85.08	*1971
275	96.84	100.56	101.88	*1974
300	115.08	118.92	120.24	*1977

\* Note: Design Specification Constraint

336.4 KCMIL, 19 STRAND, AAC, 80 MIL HDPE COVERING, "CRABAPPLE" MAINTENANCE ONLY			
ISSUE	PAGE NUMBER	OVERHEAD CONSTRUCTION STANDARD	
1/07	6-204		

© 2022 PPL Corporation. All rights reserved.

Doc. # ST. 06.00.004

Std. Item:	
Item ID:	9315425
CU:	C33ALSTPER/T

PHYSICAL PROPERTIES		LOADING PROPERTIES		ELECTRICAL PROPERTIES		
R.B.S.	5535 lbs.	TRANSVERSE	0.5949 Lb/Ft	SUMMER (37.7°C)	MAXIMUM AMPACITY	WINTER (10°C)
C.S.A.	0.2757 sq. in.	VERTICAL	1.194 Lb/Ft		NORMAL	675
R. (@ 25°C)	0.0528 Ω / 1000'	TOTAL	1.634 Lb/Ft	441	EMERGENCY	735
R. (@ 75°C)	0.0630 Ω / 1000'			541		
TEMP. LIMIT	167°F (75°C) / 194°F (90°C)	SWING	44.93°			
CONDUCTOR DIAMETER	0.666"					
COMPLETE DIAMETER	0.786"					
WEIGHT	394 lbs / 1000'					

FINAL SAG TABLE								
LOADING (UNLOADED CONDITIONS)								
TEMP. °F	0	32	60	90	120	158	176	194
TEMP. °C	-18	0	15	32	50	70	80	90
	Unloaded	Unloaded	Unloaded	Unloaded	Unloaded	Unloaded	Unloaded	Unloaded
DEAD END SPAN (FEET)								
50	1.08	2.88	6.48	9.48	11.76	14.28	15.36	16.32
75	2.40	5.64	10.32	14.64	18.00	21.60	23.16	24.60
100	4.32	9.00	14.76	20.04	24.48	29.16	31.20	33.12
125	8.40	15.60	22.08	27.96	33.00	38.52	40.92	43.20
150	15.36	24.12	30.84	37.20	42.72	48.96	51.72	54.36
175	24.84	34.08	41.16	47.88	53.88	60.60	63.60	66.48
200	36.36	45.72	52.92	59.88	66.24	73.56	76.80	79.92
225	49.44	58.80	66.12	73.32	79.92	87.72	91.20	94.44
250	64.08	73.44	80.88	88.20	95.16	103.20	106.92	110.40
275	80.28	89.64	97.08	104.64	111.72	120.12	123.96	127.56
300	98.04	107.28	114.84	122.52	129.72	138.48	142.32	146.16

FINAL SAG TABLE				
LOADING (LOADED CONDITIONS)				TENSION (LBS.)
TEMP. °F	0	32	60	0
TEMP. °C	-20	0	15	-20
	4 LB. WIND, ½" ICE	½" ICE	6 LB. WIND	4 LB. WIND, ½" ICE
DEAD END SPAN (FEET)				
50	3.72	5.28	6.72	1622
75	7.68	9.48	11.04	1807
100	12.36	14.40	15.72	1990
125	19.32	21.96	23.16	*1978
150	27.96	30.84	32.16	*1970
175	38.16	41.28	42.48	*1968
200	49.80	53.16	54.36	*1969
225	63.00	66.48	67.56	*1971
250	77.76	81.24	82.44	*1973
275	93.96	97.56	98.64	*1976
300	111.72	115.44	116.40	*1978

\* Note: Design Specification Constraint

336.4 KCMIL, 19 STRAND, AAC, 60 MIL HDPE COVERING, "ANONA"  
**MAINTENANCE ONLY**

	<b>OVERHEAD CONSTRUCTION STANDARD</b>	PAGE NUMBER	ISSUE
		6-205	7/15

PHYSICAL PROPERTIES		LOADING PROPERTIES		ELECTRICAL PROPERTIES		
R.B.S.	8350 lbs.	TRANSVERSE	0.5205 Lb/Ft	SUMMER (37.7°C)	MAXIMUM AMPACITY	WINTER (10°C)
C.S.A.	0.1939 sq. in.	VERTICAL	0.952 Lb/Ft			
R. (@ 25°C)	0.0822 Ω / 1000'	TOTAL	1.385 Lb/Ft	360	NORMAL	504
R. (@ 75°C)	0.1160 Ω / 1000'			399	EMERGENCY	527
TEMP. LIMIT	176°F (80°C) / 194°F (90°C)	SWING	44.05°			
CONDUCTOR DIAMETER	0.563"					
WEIGHT	291 lbs.					

FINAL SAG TABLE								
TEMP. °F	LOADING (UNLOADED CONDITIONS)							
	0	32	60	90	120	158	176	194
	TEMP. °C	-18	0	15	32	50	70	80
	Unloaded	Unloaded	Unloaded	Unloaded	Unloaded	Unloaded	Unloaded	Unloaded
DEAD END SPAN (FEET)								
50	0.60	0.96	1.92	3.96	5.40	7.20	8.04	8.88
75	1.44	2.28	4.68	8.04	9.96	12.48	13.56	14.64
100	2.76	4.80	8.88	13.32	15.72	18.60	20.04	21.24
125	4.92	8.76	14.52	19.80	22.56	25.92	27.48	28.92
150	8.64	14.76	21.48	27.36	30.48	34.20	35.88	37.56
175	14.40	22.56	29.88	36.24	39.60	43.56	45.48	47.28
200	22.68	32.04	39.48	46.32	49.80	54.12	56.16	58.08
225	33.24	42.96	50.52	57.60	61.32	65.88	67.92	69.96
250	45.48	55.20	62.88	70.20	74.04	78.84	81.00	83.16
275	59.16	68.76	76.44	84.00	87.96	92.88	95.16	97.44
300	74.16	83.64	91.44	99.00	103.20	108.24	110.64	112.92

FINAL SAG TABLE				
TEMP. °F	LOADING (LOADED CONDITIONS)			TENSION (LBS.)
	0	32	60	0
	TEMP. °C	-20	0	15
	4 LB. WIND, ½" ICE	½" ICE	6 LB. WIND	4 LB. WIND, ½" ICE
DEAD END SPAN (FEET)				
50	2.64	2.76	2.52	*2000
75	5.88	6.24	5.76	*2000
100	10.44	10.92	10.20	*2000
125	16.20	16.92	16.08	*2000
150	23.40	24.24	23.16	*2000
175	31.80	32.76	31.56	*2000
200	41.52	42.60	41.28	*2000
225	52.68	53.64	52.32	*2000
250	65.04	66.12	64.68	*2000
275	78.60	79.80	78.36	*2000
300	93.60	94.80	93.24	*2000

\* Note: Design Specification Constraint

4/0, 6/1 STRANDING, BARE ACSR, "PENGUIN" MAINTENANCE ONLY			
ISSUE	PAGE NUMBER	OVERHEAD CONSTRUCTION STANDARD	
7/10	6-206		

PHYSICAL PROPERTIES		LOADING PROPERTIES		ELECTRICAL PROPERTIES		
R.B.S.	8560 lbs.	TRANSVERSE	0.5213 Lb/Ft	SUMMER (37.7°C)	MAXIMUM AMPACITY	WINTER (10°C)
C.S.A.	0.1939 sq. in.	VERTICAL	0.893 Lb/Ft			
R. (@ 25°C)	0.0831 Ω / 1000'	TOTAL	1.334 Lb/Ft	396	NORMAL	555
R. (@ 75°C)	0.0973 Ω / 1000'			445		EMERGENCY
TEMP. LIMIT	176°F (80°C) / 194°F (90°C)	SWING	50.53°			
CONDUCTOR DIAMETER	0.563"					
WEIGHT	232 lbs.					

FINAL SAG TABLE								
TEMP. °F	LOADING (UNLOADED CONDITIONS)							
	0	32	60	90	120	158	176	194
TEMP. °C	-18	0	15	32	50	70	80	90
	Unloaded	Unloaded	Unloaded	Unloaded	Unloaded	Unloaded	Unloaded	Unloaded
DEAD END SPAN (FEET)								
50	0.48	0.72	1.44	4.80	8.28	11.52	12.72	13.92
75	1.08	1.80	3.72	8.76	13.44	17.88	19.80	21.48
100	2.04	3.48	7.20	13.80	19.32	24.96	27.36	29.52
125	3.60	6.36	12.24	19.80	26.16	32.88	35.64	38.16
150	6.00	10.92	18.84	27.00	34.08	41.52	44.64	47.64
175	9.72	17.64	26.64	35.40	42.96	51.12	54.60	57.96
200	15.60	26.28	35.88	45.00	52.92	61.68	65.52	69.12
225	24.36	36.60	46.44	55.80	64.08	73.32	77.40	81.24
250	35.52	48.36	58.32	67.80	76.32	86.04	90.36	94.56
275	48.60	61.44	71.40	81.00	89.76	99.96	104.40	108.72
300	63.00	75.72	85.80	95.52	104.52	114.96	119.64	124.08

FINAL SAG TABLE				
TEMP. °F	LOADING (LOADED CONDITIONS)			TENSION (LBS.)
	0	32	60	0
TEMP. °C	-20	0	15	-20
	4 LB. WIND, ½" ICE	½" ICE	6 LB. WIND	4 LB. WIND, ½" ICE
DEAD END SPAN (FEET)				
50	2.52	2.64	2.16	*2000
75	5.64	5.88	5.04	*2000
100	9.96	10.32	9.24	*2000
125	15.60	16.08	14.76	*2000
150	22.56	23.04	21.48	*2000
175	30.60	31.20	29.52	*2000
200	40.08	40.68	38.88	*2000
225	50.64	51.36	49.44	*2000
250	62.52	63.24	61.32	*2000
275	75.72	76.44	74.40	*2000
300	90.12	90.84	88.80	*2000

\* Note: Design Specification Constraint

4/0, 7 STRAND, BARE AAAC, "ALLIANCE" MAINTENANCE ONLY			
	OVERHEAD CONSTRUCTION STANDARD	PAGE NUMBER	ISSUE
		6-207	7/10

© 2022 PPL Corporation. All rights reserved. Doc. # ST. 06.00.004

Std. Item:	W18B
Item ID:	9315759 <sup>Y</sup>
CU:	C40ALSTBR

PHYSICAL PROPERTIES		LOADING PROPERTIES		ELECTRICAL PROPERTIES		
R.B.S.	3830 lbs.	TRANSVERSE	0.5073 Lb/Ft	SUMMER (37.7°C)	MAXIMUM AMPACITY	WINTER (10°C)
C.S.A.	0.1663 sq. in.	VERTICAL	0.835 Lb/Ft			
R. (@ 25°C)	0.0835 Ω / 1000'	TOTAL	1.277 Lb/Ft	383	NORMAL	535
R. (@ 75°C)	0.0999 Ω / 1000'			429	EMERGENCY	565
TEMP. LIMIT	176°F (80°C) / 194°F (90°C)	SWING	52.73°			
CONDUCTOR DIAMETER	0.522"					
WEIGHT	199 lbs.					

FINAL SAG TABLE								
TEMP. °F	LOADING (UNLOADED CONDITIONS)							
	0	32	60	90	120	158	176	194
TEMP. °C	-18	0	15	32	50	70	80	90
	Unloaded	Unloaded	Unloaded	Unloaded	Unloaded	Unloaded	Unloaded	Unloaded
DEAD END SPAN (FEET)								
50	0.72	2.04	5.64	8.88	11.40	13.92	15.00	16.08
75	1.80	4.20	9.12	13.80	17.40	21.12	22.68	24.12
100	3.12	6.96	13.08	18.84	23.40	28.32	30.48	32.40
125	4.92	10.08	17.28	24.12	29.76	35.76	38.40	40.80
150	6.96	13.56	21.72	29.64	36.24	43.32	46.32	49.20
175	9.60	17.40	26.52	35.40	42.84	51.00	54.60	57.84
200	13.32	23.04	33.00	42.48	50.76	59.76	63.72	67.44
225	21.00	33.12	43.44	53.16	61.68	71.28	75.48	79.44
250	31.68	44.88	55.32	65.16	73.92	83.88	88.32	92.52
275	44.64	57.96	68.28	78.24	87.36	97.68	102.24	106.68
300	59.16	72.36	82.68	92.76	101.88	112.56	117.36	121.92

FINAL SAG TABLE				
TEMP. °F	LOADING (LOADED CONDITIONS)			TENSION (LBS.)
	0	32	60	0
TEMP. °C	-20	0	15	-20
	4 LB. WIND, ½" ICE	½" ICE	6 LB. WIND	4 LB. WIND, ½" ICE
DEAD END SPAN (FEET)				
50	4.20	5.04	6.12	1149
75	8.28	9.36	10.08	1294
100	13.32	14.28	14.52	1437
125	18.96	19.68	19.20	1575
150	25.32	25.68	24.24	1706
175	32.04	32.04	29.64	1831
200	3.33	3.31	3.05	*1915
225	4.22	4.19	3.92	*1915
250	5.21	5.18	4.90	*1915
275	6.31	6.27	5.99	*1915
300	7.51	7.47	7.18	*1915

\* Note: Design Specification Constraint

4/0, 7 STRAND, BARE AAC, "OXLIP" MAINTENANCE ONLY			
ISSUE	PAGE NUMBER	OVERHEAD CONSTRUCTION STANDARD	
7/15	6-208		

PHYSICAL PROPERTIES		LOADING PROPERTIES		ELECTRICAL PROPERTIES		
R.B.S.	3445 lbs.	TRANSVERSE	0.5475 Lb/Ft	SUMMER (37.7°C)	MAXIMUM AMPACITY	WINTER (10°C)
C.S.A.	0.1776 sq. in.	VERTICAL	0.961 Lb/Ft			
R. (@ 25°C)	0.0835 Ω / 1000'	TOTAL	1.406 Lb/Ft	331	NORMAL	501
R. (@ 75°C)	0.1000 Ω / 1000'			404	EMERGENCY	545
TEMP. LIMIT	167°F (75°C) / 194°F (90°C)	SWING	51.98°			
CONDUCTOR DIAMETER	0.522"					
COMPLETE DIAMETER	0.642"					
WEIGHT	251 lbs / 1000'					

FINAL SAG TABLE								
TEMP. °F	LOADING (UNLOADED CONDITIONS)							
	0	32	60	90	120	158	176	194
TEMP. °C	-18	0	15	32	50	70	80	90
	Unloaded	Unloaded	Unloaded	Unloaded	Unloaded	Unloaded	Unloaded	Unloaded
DEAD END SPAN (FEET)								
50	1.08	3.24	6.72	9.72	12.00	14.52	15.48	16.44
75	2.40	6.00	10.80	15.00	18.36	21.96	23.40	24.84
100	4.32	9.48	15.24	20.52	24.84	29.52	31.56	33.48
125	6.84	13.32	20.16	26.28	31.56	37.32	39.84	42.12
150	10.56	18.84	26.28	33.36	39.36	46.08	48.96	51.60
175	18.48	28.32	36.24	43.56	49.92	57.24	60.36	63.36
200	29.40	39.72	47.64	55.20	61.92	69.60	73.08	76.32
225	42.36	52.56	60.60	68.28	75.36	83.52	87.12	90.60
250	57.00	67.08	75.12	82.92	90.24	98.64	102.48	106.08
275	73.20	83.16	91.20	99.12	106.56	115.32	119.28	123.12
300	90.96	100.80	108.72	116.76	124.32	133.32	137.40	141.36

FINAL SAG TABLE				
TEMP. °F	LOADING (LOADED CONDITIONS)			TENSION (LBS.)
	0	32	60	0
TEMP. °C	-20	0	15	-20
	4 LB. WIND, ½" ICE	½" ICE	6 LB. WIND	4 LB. WIND, ½" ICE
DEAD END SPAN (FEET)				
50	4.68	6.00	7.20	1118
75	9.24	10.56	11.64	1289
100	14.52	15.96	16.56	1450
125	20.64	21.84	21.84	1600
150	27.84	29.04	28.44	*1703
175	37.80	39.12	38.40	*1707
200	49.32	50.64	49.92	*1711
225	62.40	63.84	63.00	*1713
250	76.92	78.36	77.52	*1715
275	93.00	94.56	93.60	*1716
300	110.64	112.20	111.24	*1717

\* Note: Design Specification Constraint

4/0, 7 STRAND, AAC, 60 MIL PE COVERING, "OLIVE" MAINTENANCE ONLY			
	OVERHEAD CONSTRUCTION STANDARD	PAGE NUMBER	ISSUE
		6-209	7/10

© 2022 PPL Corporation. All rights reserved. Doc. # ST. 06.00.004

PHYSICAL PROPERTIES		LOADING PROPERTIES		ELECTRICAL PROPERTIES		
R.B.S.	8560 lbs.	TRANSVERSE	0.5604 Lb/Ft	SUMMER (37.7°C)	MAXIMUM AMPACITY	WINTER (10°C)
C.S.A.	0.1939 sq. in.	VERTICAL	1.043 Lb/Ft			
R. (@ 25°C)	0.0831 Ω / 1000'	TOTAL	1.484 Lb/Ft	337	NORMAL	512
R. (@ 75°C)	0.0973 Ω / 1000'			412	EMERGENCY	557
TEMP. LIMIT	167°F (75°C) / 194°F (90°C)	SWING	48.05°			
CONDUCTOR DIAMETER	0.563"					
COMPLETE DIAMETER	0.683"					
WEIGHT	307 lbs / 1000'					

FINAL SAG TABLE								
TEMP. °F	LOADING (UNLOADED CONDITIONS)							
	0	32	60	90	120	158	176	194
TEMP. °C	-18	0	15	32	50	70	80	90
	Unloaded	Unloaded	Unloaded	Unloaded	Unloaded	Unloaded	Unloaded	Unloaded
DEAD END SPAN (FEET)								
50	0.60	0.96	1.92	5.28	8.52	11.64	12.96	14.04
75	1.44	2.40	4.80	9.60	13.92	18.24	20.04	21.72
100	2.88	4.92	9.12	15.12	20.28	25.68	27.96	30.00
125	5.04	8.88	15.00	21.84	27.72	34.08	36.72	39.12
150	8.64	15.00	22.44	29.88	36.24	43.32	46.32	49.20
175	14.40	23.16	31.32	39.12	46.08	53.76	57.00	60.24
200	22.92	33.24	41.76	49.80	57.00	65.28	68.88	72.24
225	33.84	44.76	53.52	61.80	69.36	78.00	81.84	85.44
250	46.80	57.96	66.60	75.12	82.92	92.04	96.00	99.84
275	61.44	72.48	81.24	89.88	97.92	107.28	111.48	115.44
300	77.52	88.44	97.20	105.96	114.12	123.84	128.16	132.36

FINAL SAG TABLE				
TEMP. °F	LOADING (LOADED CONDITIONS)			TENSION (LBS.)
	0	32	60	0
TEMP. °C	-20	0	15	-20
	4 LB. WIND, ½" ICE	½" ICE	6 LB. WIND	4 LB. WIND, ½" ICE
DEAD END SPAN (FEET)				
50	2.76	3.00	2.76	*1999
75	6.24	6.72	6.12	*2000
100	11.16	11.76	10.92	*2000
125	17.40	18.24	17.16	*2000
150	25.08	26.04	24.84	*2000
175	34.08	35.28	33.84	*2000
200	44.52	45.84	44.28	*2000
225	56.40	57.72	56.04	*2000
250	69.60	71.04	69.36	*2000
275	84.24	85.68	83.88	*2000
300	100.32	101.76	99.96	*2000

\* Note: Design Specification Constraint

4/0, 7 STRAND, AAAC, 60 MIL PE COVERING, "PLANETREE" MAINTENANCE ONLY			
ISSUE	PAGE NUMBER	OVERHEAD CONSTRUCTION STANDARD	
7/18	6-210		

PHYSICAL PROPERTIES		LOADING PROPERTIES		ELECTRICAL PROPERTIES		
R.B.S.	3620 lbs.	TRANSVERSE	0.5451 Lb/Ft	SUMMER (37.7 °C)	MAXIMUM AMPACITY	WINTER (10 °C)
C.S.A.	0.1678 sq. in.	VERTICAL	0.952 Lb/Ft			
R. (@ 25 °C)	0.0838 Ω / 1000'	TOTAL	1.397 Lb/Ft	330	NORMAL	499
R. (@ 75 °C)	0.1000 Ω / 1000'			402	EMERGENCY	543
TEMP. LIMIT	167 °F (75 °C) / 194 °F (90 °C)	SWING	51.87'			
CONDUCTOR DIAMETER	0.512"					
COMPLETE DIAMETER	0.632"					
WEIGHT	248 lbs / 1000'					

FINAL SAG TABLE								
TEMP. °F	LOADING (UNLOADED CONDITIONS)							
	0	32	60	90	120	158	176	194
TEMP. °C	-18	0	15	32	50	70	80	90
	Unloaded	Unloaded	Unloaded	Unloaded	Unloaded	Unloaded	Unloaded	Unloaded
DEAD END SPAN (FEET)								
50	1.08	2.52	6.00	9.12	11.52	14.04	15.12	16.08
75	2.28	5.16	9.84	14.16	17.64	21.36	22.92	24.36
100	4.08	8.40	14.04	19.44	23.88	28.80	30.84	32.76
125	6.48	12.12	18.72	25.08	30.48	36.36	38.88	41.28
150	9.24	16.20	23.76	31.08	37.32	44.28	47.16	50.04
175	13.44	22.08	30.36	38.28	45.36	53.04	56.40	59.64
200	21.96	32.40	41.04	49.32	56.64	64.80	68.52	71.88
225	33.48	44.52	53.28	61.68	69.24	77.88	81.72	85.44
250	47.16	58.20	66.96	75.48	83.28	92.28	96.24	100.08
275	62.40	73.44	82.08	90.72	98.64	108.00	112.08	116.16
300	79.32	90.12	98.76	107.40	115.44	125.04	129.36	133.56

FINAL SAG TABLE				
TEMP. °F	LOADING (LOADED CONDITIONS)			TENSION (LBS.)
	0	32	60	0
TEMP. °C	-20	0	15	-20
	4 LB. WIND, ½" ICE	½" ICE	6 LB. WIND	4 LB. WIND, ½" ICE
DEAD END SPAN (FEET)				
50	4.68	5.64	6.60	1129
75	9.12	10.20	10.80	1287
100	14.52	15.60	15.60	1439
125	20.64	21.48	20.76	1582
150	27.48	27.96	26.40	1717
175	35.40	35.76	33.48	*1810
200	46.32	46.68	44.16	*1810
225	58.68	58.92	56.40	*1810
250	72.36	72.72	70.08	*1810
275	87.60	87.96	85.32	*1810
300	104.28	104.64	101.88	*1810

\* Note: Design Specification Constraint

4/0, 19 STRAND, AAC, 60 MIL PE COVERING, "POMEGRANITE" MAINTENANCE ONLY			
	OVERHEAD CONSTRUCTION STANDARD	PAGE NUMBER	ISSUE
		6-211	7/10

© 2022 PPL Corporation. All rights reserved.

Doc. # ST. 06.00.004

Std. Item:	
Item ID:	9315758
CU:	C10ASSTBRRLR/T

PHYSICAL PROPERTIES		LOADING PROPERTIES		ELECTRICAL PROPERTIES		
R.B.S.	4380 lbs.	TRANSVERSE	0.4655 Lb/Ft	SUMMER (37.7°C)	MAXIMUM AMPACITY	WINTER (10°C)
C.S.A.	0.0968 sq. in.	VERTICAL	0.704 Lb/Ft			
R. (@ 25°C)	0.1630 Ω / 1000'	TOTAL	1.144 Lb/Ft	242	NORMAL	335
R. (@ 75°C)	0.2160 Ω / 1000'			268	EMERGENCY	351
TEMP. LIMIT	176°F (80°C) / 194°F (90°C)	SWING	53.88°			
CONDUCTOR DIAMETER	0.398"					
WEIGHT	145 lbs.					

FINAL SAG TABLE								
TEMP. °F	LOADING (UNLOADED CONDITIONS)							
	0	32	60	90	120	158	176	194
TEMP. °C	-18	0	15	32	50	70	80	90
	Unloaded	Unloaded	Unloaded	Unloaded	Unloaded	Unloaded	Unloaded	Unloaded
DEAD END SPAN (FEET)								
50	0.48	0.72	1.32	2.88	3.96	5.76	6.60	7.56
75	1.08	1.68	2.88	5.52	7.20	9.60	10.80	11.88
100	2.04	3.00	4.92	8.76	10.80	13.68	15.12	16.56
125	3.12	4.56	7.44	12.36	14.76	18.12	19.80	21.48
150	4.44	6.60	10.20	16.20	18.84	22.68	24.60	26.52
175	6.12	8.88	13.44	20.16	23.28	27.48	29.64	31.68
200	7.92	11.40	16.92	24.48	27.84	32.52	34.80	37.08
225	10.08	14.40	20.64	28.92	32.64	37.56	40.08	42.48
250	12.36	17.52	24.72	33.60	37.56	42.84	45.48	48.12
275	17.28	24.72	33.96	42.48	46.92	52.80	55.68	58.44
300	24.72	34.92	45.60	53.40	58.20	64.56	67.56	70.56

FINAL SAG TABLE				
TEMP. °F	LOADING (LOADED CONDITIONS)			TENSION (LBS.)
	0	32	60	0
TEMP. °C	-20	0	15	-20
	4 LB. WIND, ½" ICE	½" ICE	6 LB. WIND	4 LB. WIND, ½" ICE
DEAD END SPAN (FEET)				
50	3.60	3.24	2.16	1197
75	7.44	6.72	4.44	1292
100	12.36	10.92	7.32	1394
125	17.88	15.84	10.68	1498
150	24.12	21.24	14.52	1601
175	30.84	27.12	18.60	1702
200	38.16	33.48	23.04	1800
225	45.84	40.20	27.84	1896
250	54.00	47.16	32.88	1989
275	64.92	57.48	42.36	*2000
300	77.28	69.36	53.88	*2000

\* Note: Design Specification Constraint

1/0, 6/1 STRANDING, BARE ACSR, "RAVEN" MAINTENANCE ONLY			
ISSUE	PAGE NUMBER	OVERHEAD CONSTRUCTION STANDARD	
7/15	6-212		

© 2022 PPL Corporation. All rights reserved.

Doc. # ST. 06.00.004

Std. Item:	
Item ID:	
CU:	C10ASSTLTRT

PHYSICAL PROPERTIES		LOADING PROPERTIES		ELECTRICAL PROPERTIES		
R.B.S.	4160 lbs.	TRANSVERSE	0.5407 Lb/Ft	SUMMER (37.7°C)	MAXIMUM AMPACITY	WINTER (10°C)
C.S.A.	0.1348 sq. in.	VERTICAL	0.921 Lb/Ft	210	NORMAL	320
R. (@ 25°C)	0.1633 Ω / 1000'	TOTAL	1.368 Lb/Ft	256	EMERGENCY	348
R. (@ 75°C)	0.2160 Ω / 1000'	SWING	53.82°			
TEMP. LIMIT	167°F (75°C) / 194°F (90°C)					
CONDUCTOR DIAMETER	0.398"					
COMPLETE DIAMETER	0.6518"					
WEIGHT	226 lbs / 1000'					

FINAL SAG TABLE								
TEMP. °F	LOADING (UNLOADED CONDITIONS)							
	0	32	60	90	120	158	176	194
TEMP. °C	-18	0	15	32	50	70	80	90
	Unloaded	Unloaded	Unloaded	Unloaded	Unloaded	Unloaded	Unloaded	Unloaded
DEAD END SPAN (FEET)								
50	0.84	1.56	3.72	5.76	7.20	8.88	9.60	10.32
75	1.80	3.36	6.72	9.72	11.64	13.92	15.00	15.96
100	3.24	5.76	10.08	14.16	16.44	19.32	20.64	21.84
125	5.04	8.64	13.92	18.96	21.60	24.96	26.52	27.96
150	7.32	12.00	18.12	24.12	27.12	30.84	32.64	34.32
175	9.96	15.72	22.68	29.52	32.88	37.08	39.00	40.92
200	14.28	21.60	29.52	36.84	40.56	45.12	47.16	49.32
225	22.32	31.68	40.08	47.52	51.36	56.28	58.44	60.72
250	33.24	43.56	52.20	59.40	63.60	68.64	70.92	73.20
275	46.32	57.00	65.52	72.72	77.04	82.20	84.72	87.00
300	61.20	71.76	80.28	87.36	91.68	97.08	99.60	102.12

FINAL SAG TABLE				
TEMP. °F	LOADING (LOADED CONDITIONS)			TENSION (LBS.)
	0	32	60	0
TEMP. °C	-20	0	15	-20
	4 LB. WIND, ½" ICE	½" ICE	6 LB. WIND	4 LB. WIND, ½" ICE
DEAD END SPAN (FEET)				
50	4.20	4.56	4.68	1229
75	8.40	8.76	8.16	1377
100	13.44	13.56	12.24	1523
125	19.32	19.08	16.80	1664
150	25.68	24.96	21.72	1800
175	32.64	31.44	27.00	1928
200	41.04	39.48	34.20	*2000
225	51.96	50.28	44.76	*2000
250	64.20	62.40	56.76	*2000
275	77.64	75.84	70.08	*2000
300	92.40	90.48	84.72	*2000

\* Note: Design Specification Constraint

1/0, 6/1 STRANDING, ACSR, 110 MIL PE COVERING, "ALMOND" MAINTENANCE ONLY			
	OVERHEAD CONSTRUCTION STANDARD	PAGE NUMBER	ISSUE
		6-213	7/10

© 2022 PPL Corporation. All rights reserved.

Doc. # ST. 06.00.004

Std. Item:	
Item ID:	
CU:	C10ASSTPER/T

PHYSICAL PROPERTIES		LOADING PROPERTIES		ELECTRICAL PROPERTIES		
R.B.S.	4160 lbs.	TRANSVERSE	0.5069 Lb/Ft	SUMMER (37.7°C)	MAXIMUM AMPACITY	WINTER (10°C)
C.S.A.	0.1081 sq. in.	VERTICAL	0.827 Lb/Ft			
R. (@ 25°C)	0.1633 Ω / 1000'	TOTAL	1.270 Lb/Ft	220	NORMAL	330
R. (@ 75°C)	0.2160 Ω / 1000'			267	EMERGENCY	359
TEMP. LIMIT	167°F (75°C) / 194°F (90°C)	SWING	53.17°			
CONDUCTOR DIAMETER	0.398"					
COMPLETE DIAMETER	0.518"					
WEIGHT	194 lbs / 1000'					

FINAL SAG TABLE								
TEMP. °F	LOADING (UNLOADED CONDITIONS)							
	0	32	60	90	120	158	176	194
TEMP. °C	-18	0	15	32	50	70	80	90
	Unloaded	Unloaded	Unloaded	Unloaded	Unloaded	Unloaded	Unloaded	Unloaded
DEAD END SPAN (FEET)								
50	0.72	1.20	2.40	4.32	5.76	7.44	8.28	9.00
75	1.56	2.52	4.68	7.92	9.72	12.00	13.08	14.16
100	2.76	4.44	7.68	11.88	14.04	16.92	18.24	19.56
125	4.32	6.84	11.04	16.32	18.84	22.08	23.64	25.20
150	6.24	9.60	14.76	21.00	23.88	27.60	29.28	31.08
175	8.52	12.84	18.84	25.92	29.16	33.24	35.16	37.20
200	11.16	16.44	23.28	31.20	34.68	39.12	41.28	43.44
225	14.16	20.40	27.96	36.60	40.32	45.24	47.64	49.92
250	20.88	29.52	38.40	46.80	50.88	56.16	58.68	61.08
275	30.48	41.04	50.52	58.56	63.00	68.52	71.16	73.68
300	42.84	54.36	64.08	71.64	76.32	82.08	84.72	87.48

FINAL SAG TABLE				
TEMP. °F	LOADING (LOADED CONDITIONS)			TENSION (LBS.)
	0	32	60	0
TEMP. °C	-20	0	15	-20
	4 LB. WIND, ½" ICE	½" ICE	6 LB. WIND	4 LB. WIND, ½" ICE
DEAD END SPAN (FEET)				
50	4.08	4.08	3.36	1183
75	8.28	8.04	6.48	1303
100	13.32	12.72	10.08	1427
125	19.20	18.12	14.28	1548
150	25.68	24.00	18.84	1666
175	32.76	30.36	23.76	1780
200	40.32	37.08	28.92	1890
225	48.36	44.40	34.56	1996
250	59.52	55.20	45.00	*2000
275	72.12	67.44	57.00	*2000
300	85.80	80.88	70.32	*2000

\* Note: Design Specification Constraint

1/0 ACSR, 6/1 STANDING, 60 MIL PE COVERING, "ALMOND" MAINTENANCE ONLY			
ISSUE	PAGE NUMBER	OVERHEAD CONSTRUCTION STANDARD	
7/15	6-214		

© 2022 PPL Corporation. All rights reserved.

Doc. # ST. 06.00.004

Std. Item:	
Item ID:	9314543
CU:	C10AACPERT

PHYSICAL PROPERTIES		LOADING PROPERTIES		ELECTRICAL PROPERTIES		
R.B.S.	4194 lbs.	TRANSVERSE	0.5286 Lb/Ft	SUMMER (37.7° C)	MAXIMUM AMPACITY	WINTER (10° C)
C.S.A.	0.1081 sq. in.	VERTICAL	0.843 Lb/Ft	228	NORMAL	344
R. (@ 25° C)	0.1660 Ω / 1000'	TOTAL	1.295 Lb/Ft	278	EMERGENCY	374
R. (@ 75° C)	0.1950 Ω / 1000'	SWING	60.55°			
TEMP. LIMIT	167°F (75° C) / 194°F (90° C)					
CONDUCTOR DIAMETER	0.468"					
COMPLETE DIAMETER	0.588"					
WEIGHT	166 lbs / 1000'					

FINAL SAG TABLE								
TEMP. °F	LOADING (UNLOADED CONDITIONS)							
	0	32	60	90	120	158	176	194
TEMP. °C	-18	0	15	32	50	70	80	90
	Unloaded	Unloaded	Unloaded	Unloaded	Unloaded	Unloaded	Unloaded	Unloaded
DEAD END SPAN (FEET)								
50	0.60	0.96	1.56	4.20	7.68	11.04	12.36	13.56
75	1.32	2.04	3.48	7.44	12.12	16.92	18.72	20.52
100	2.40	3.60	6.00	11.16	16.92	22.92	25.32	27.60
125	3.72	5.52	8.88	15.12	21.84	29.16	32.16	34.92
150	5.40	7.92	12.24	19.56	27.12	35.52	39.00	42.24
175	7.32	10.56	15.96	24.24	32.64	42.12	46.08	49.92
200	9.48	13.68	20.04	29.16	38.52	48.96	53.40	57.60
225	12.00	17.16	24.48	34.44	44.52	55.92	60.84	65.52
250	14.88	20.88	29.16	39.96	50.76	63.12	68.52	73.56
275	20.40	28.80	38.88	50.64	61.80	74.64	80.16	85.44
300	29.16	40.56	52.20	64.32	75.72	88.68	94.32	99.72

FINAL SAG TABLE				
TEMP. °F	LOADING (LOADED CONDITIONS)			TENSION (LBS.)
	0	32	60	0
TEMP. °C	-20	0	15	-20
	4 LB. WIND, ½" ICE	½" ICE	6 LB. WIND	4 LB. WIND, ½" ICE
DEAD END SPAN (FEET)				
50	4.20	3.96	3.00	1161
75	8.64	8.16	6.00	1261
100	14.16	13.20	9.84	1368
125	20.52	18.84	14.04	1476
150	27.60	25.20	18.84	1582
175	35.28	32.04	24.00	1685
200	43.56	39.36	29.52	1785
225	52.32	47.16	35.28	1882
250	61.44	55.32	41.52	1976
275	73.56	66.72	51.84	*2000
300	87.48	80.28	64.92	*2000

\* Note: Design Specification Constraint

1/0, 7 STRAND, AAAC, 60 MIL XLPE COVERING, "OILNUT" – 15 kV			
	OVERHEAD CONSTRUCTION STANDARD	PAGE NUMBER	ISSUE
		6-215	7/15

© 2022 PPL Corporation. All rights reserved.

Doc. # ST. 06.00.004

Std. Item:	W12B
Item ID:	9306923 <sup>Y</sup>
CU:	C02ASSTBR

PHYSICAL PROPERTIES		LOADING PROPERTIES		ELECTRICAL PROPERTIES		
R.B.S.	2850 lbs.	TRANSVERSE	0.4379 Lb/Ft	SUMMER (37.7°C)	MAXIMUM AMPACITY	WINTER (10°C)
C.S.A.	0.0608 sq. in.	VERTICAL	0.599 Lb/Ft			
R. (@ 25°C)	0.2591 Ω / 1000'	TOTAL	1.042 Lb/Ft	183	NORMAL	251
R. (@ 75°C)	0.3360 Ω / 1000'			203	EMERGENCY	264
TEMP. LIMIT	176°F (80°C) / 194°F (90°C)	SWING	60.01°			
CONDUCTOR DIAMETER	0.316"					
WEIGHT	91 lbs.					

FINAL SAG TABLE								
TEMP. °F	LOADING (UNLOADED CONDITIONS)							
	0	32	60	90	120	158	176	194
TEMP. °C	-18	0	15	32	50	70	80	90
	Unloaded	Unloaded	Unloaded	Unloaded	Unloaded	Unloaded	Unloaded	Unloaded
DEAD END SPAN (FEET)								
50	0.48	0.72	1.20	3.12	4.32	6.24	7.08	7.92
75	1.08	1.56	2.76	5.88	7.56	10.08	11.16	12.36
100	1.92	2.88	4.68	8.88	11.04	14.04	15.48	16.80
125	3.00	4.44	7.08	12.24	14.64	18.00	19.68	21.36
150	4.32	6.36	9.84	15.60	18.36	22.20	24.12	25.92
175	5.88	8.52	12.96	19.20	22.20	26.40	28.44	30.48
200	7.68	11.04	16.32	22.80	26.04	30.48	32.76	35.04
225	10.44	15.24	22.08	28.32	31.92	36.96	39.36	41.88
250	16.80	25.08	34.32	39.12	43.32	48.96	51.60	54.24
275	27.60	38.88	47.40	52.08	56.76	62.76	65.52	68.28
300	43.08	55.32	62.04	66.96	72.00	78.12	80.88	83.76

FINAL SAG TABLE				
TEMP. °F	LOADING (LOADED CONDITIONS)			TENSION (LBS.)
	0	32	60	0
TEMP. °C	-20	0	15	-20
	4 LB. WIND, ½" ICE	½" ICE	6 LB. WIND	4 LB. WIND, ½" ICE
DEAD END SPAN (FEET)				
50	4.68	4.08	2.28	827
75	9.60	8.04	4.80	921
100	15.36	12.96	7.92	1016
125	22.08	18.60	11.52	1109
150	29.40	24.72	15.48	1199
175	37.20	31.32	19.92	1286
200	45.60	38.40	24.60	1370
225	55.56	47.04	31.44	*1425
250	68.64	59.40	43.44	*1425
275	83.04	73.32	57.24	*1425
300	98.88	88.56	72.84	*1425

\* Note: Design Specification Constraint

#2, 6/1 STRANDING, BARE ACSR, "SPARROW" MAINTENANCE ONLY			
ISSUE	PAGE NUMBER	OVERHEAD CONSTRUCTION STANDARD	
7/15	6-216		

© 2022 PPL Corporation. All rights reserved.

Doc. # ST. 06.00.004

Std. Item:	
Item ID:	
CU:	C02ASSTPER/T

PHYSICAL PROPERTIES		LOADING PROPERTIES		ELECTRICAL PROPERTIES		
R.B.S.	2710 lbs.	TRANSVERSE	0.4978 Lb/Ft	SUMMER (37.7°C)	MAXIMUM AMPACITY	WINTER (10°C)
C.S.A.	0.0672 sq. in.	VERTICAL	0.739 Lb/Ft	178	NORMAL	266
R. (@ 25°C)	0.2591 Ω / 1000'	TOTAL	1.191 Lb/Ft	216	EMERGENCY	289
R. (@ 75°C)	0.3360 Ω / 1000'					
TEMP. LIMIT	167°F (75°C) / 194°F (90°C)	SWING	64.37°			
CONDUCTOR DIAMETER	0.406"					
COMPLETE DIAMETER	0.496"					
WEIGHT	119 lbs / 1000'					

FINAL SAG TABLE								
TEMP. °F	LOADING (UNLOADED CONDITIONS)							
	0	32	60	90	120	158	176	194
TEMP. °C	-18	0	15	32	50	70	80	90
	Unloaded	Unloaded	Unloaded	Unloaded	Unloaded	Unloaded	Unloaded	Unloaded
DEAD END SPAN (FEET)								
50	0.60	0.96	1.80	4.08	5.40	7.08	7.92	8.64
75	1.44	2.28	3.84	7.32	9.00	11.28	12.36	13.44
100	2.64	3.96	6.48	10.92	12.96	15.72	17.04	18.36
125	4.08	6.12	9.48	14.76	17.16	20.28	21.84	23.40
150	5.88	8.64	12.96	18.84	21.48	24.96	26.76	28.44
175	8.04	11.64	16.80	22.92	25.80	29.76	31.68	33.60
200	13.92	20.40	27.84	33.00	36.48	40.92	42.96	45.00
225	24.60	33.84	41.88	45.84	49.68	54.36	56.64	58.80
250	40.20	49.92	56.76	60.84	64.80	69.72	72.00	74.16
275	58.32	67.80	73.56	77.76	81.84	86.76	89.04	91.32
300	78.24	87.36	92.28	96.48	100.56	105.60	107.88	110.16

FINAL SAG TABLE				
TEMP. °F	LOADING (LOADED CONDITIONS)			TENSION (LBS.)
	0	32	60	0
TEMP. °C	-20	0	15	-20
	4 LB. WIND, ½" ICE	½" ICE	6 LB. WIND	4 LB. WIND, ½" ICE
DEAD END SPAN (FEET)				
50	5.40	4.92	3.48	827
75	10.68	9.60	6.84	938
100	17.04	15.12	10.92	1047
125	24.24	21.48	15.48	1152
150	32.16	28.32	20.40	1253
175	40.56	35.64	25.80	1349
200	52.80	47.28	36.84	*1355
225	66.84	60.84	50.28	*1355
250	82.44	76.20	65.64	*1355
275	99.84	93.24	82.80	*1355
300	118.80	111.96	101.64	*1355

\* Note: Design Specification Constraint

<b>#2, 6/1 STRANDING, ACSR, 45 MIL PE COVERING, "PIGNUT" MAINTENANCE ONLY</b>			
	OVERHEAD CONSTRUCTION STANDARD	PAGE NUMBER	ISSUE
		<b>6-217</b>	<b>7/15</b>

© 2022 PPL Corporation. All rights reserved.

Doc. # ST. 06.00.004

Std. Item:	
Item ID:	
CU:	C04ASBR

PHYSICAL PROPERTIES		LOADING PROPERTIES		ELECTRICAL PROPERTIES		
R.B.S.	2360 lbs.	TRANSVERSE	0.4191 Lb/Ft	SUMMER (37.7°C)	MAXIMUM AMPACITY	WINTER (10°C)
C.S.A.	0.0411 sq. in.	VERTICAL	0.538 Lb/Ft			
R. (@ 25°C)	0.4070 Ω / 1000'	TOTAL	0.982 Lb/Ft	140	NORMAL	191
R. (@ 75°C)	0.5160 Ω / 1000'			155	EMERGENCY	201
TEMP. LIMIT	176°F (80°C) / 194°F (90°C)	SWING	62.46°			
CONDUCTOR DIAMETER	0.257"					
WEIGHT	67 lbs.					

FINAL SAG TABLE								
TEMP. °F	LOADING (UNLOADED CONDITIONS)							
	0	32	60	90	120	158	176	194
	TEMP. °C	-18	0	15	32	50	70	80
	Unloaded	Unloaded	Unloaded	Unloaded	Unloaded	Unloaded	Unloaded	Unloaded
DEAD END SPAN (FEET)								
50	0.48	0.60	0.84	1.80	3.00	4.92	5.88	6.84
75	0.96	1.32	1.92	3.72	5.52	8.04	9.36	10.68
100	1.68	2.28	3.48	6.12	8.40	11.40	12.96	14.52
125	2.64	3.60	5.28	8.88	11.28	14.76	16.68	18.48
150	3.84	5.28	7.44	11.88	14.28	18.24	20.28	22.32
175	5.16	7.08	9.96	14.64	17.40	21.60	23.88	26.16
200	7.08	9.72	13.68	18.36	21.60	26.28	28.68	31.20
225	11.40	16.32	23.16	27.00	31.08	36.72	39.48	42.24
250	20.28	29.16	35.28	40.08	44.88	51.00	53.88	56.64
275	35.76	45.96	50.76	55.92	61.08	67.32	70.20	72.96
300	55.44	63.72	68.64	73.92	79.08	85.20	88.08	90.84

FINAL SAG TABLE				
TEMP. °F	LOADING (LOADED CONDITIONS)			TENSION (LBS.)
	0	32	60	0
	TEMP. °C	-20	0	-20
	4 LB. WIND, ½" ICE	½" ICE	6 LB. WIND	4 LB. WIND, ½" ICE
DEAD END SPAN (FEET)				
50	5.28	4.08	1.80	697
75	10.56	8.28	3.96	781
100	17.04	13.44	6.72	865
125	24.24	19.32	9.96	948
150	32.28	25.80	13.68	1027
175	40.92	32.76	17.76	1104
200	50.52	40.80	23.16	1166
225	63.24	52.32	33.36	*1180
250	78.12	66.36	47.40	*1180
275	94.44	82.20	63.60	*1180
300	112.44	99.60	81.60	*1180

\* Note: Design Specification Constraint

#4, 7/1 STRANDING, BARE ACSR, "SWANATE" MAINTENANCE ONLY			
ISSUE	PAGE NUMBER	OVERHEAD CONSTRUCTION STANDARD	
7/15	6-218		

© 2022 PPL Corporation. All rights reserved.

Doc. # ST. 06.00.004

Std. Item:	
CU:	C04ASPE

PHYSICAL PROPERTIES		LOADING PROPERTIES		ELECTRICAL PROPERTIES		
R.B.S.	2240 lbs.	TRANSVERSE	0.4589 Lb/Ft	SUMMER (37.7°C)	MAXIMUM AMPACITY	WINTER (10°C)
C.S.A.	0.0439 sq. in.	VERTICAL	0.627 Lb/Ft	136	NORMAL	200
R. (@ 25°C)	0.4072 Ω / 1000'	TOTAL	1.077 Lb/Ft	164	EMERGENCY	217
R. (@ 75°C)	0.5160 Ω / 1000'	SWING	66.49°			
TEMP. LIMIT	167°F (75°C) / 194°F (90°C)					
CONDUCTOR DIAMETER	0.317"					
COMPLETE DIAMETER	0.377"					
WEIGHT	82 lbs / 1000'					

FINAL SAG TABLE								
TEMP. °F	LOADING (UNLOADED CONDITIONS)							
	0	32	60	90	120	158	176	194
TEMP. °C	-18	0	15	32	50	70	80	90
	Unloaded	Unloaded	Unloaded	Unloaded	Unloaded	Unloaded	Unloaded	Unloaded
DEAD END SPAN (FEET)								
50	0.60	0.84	1.32	2.88	4.44	6.36	7.32	8.16
75	1.20	1.80	2.76	5.52	7.56	10.20	11.40	12.60
100	2.16	3.12	4.80	8.64	10.92	14.04	15.60	17.04
125	3.48	4.92	7.32	11.88	14.40	18.00	19.80	21.48
150	4.92	6.96	10.20	15.12	18.00	22.08	24.00	26.04
175	7.68	11.28	16.32	21.24	24.72	29.40	31.56	33.72
200	15.12	22.32	29.52	33.48	37.44	42.48	44.76	47.04
225	29.16	38.28	44.16	48.36	52.56	57.60	59.88	62.16
250	47.76	56.52	61.20	65.52	69.60	74.64	76.92	79.20
275	68.16	76.20	80.28	84.48	88.56	93.60	95.88	98.16
300	90.00	97.20	101.16	105.36	109.44	114.36	116.64	118.80

FINAL SAG TABLE				
TEMP. °F	LOADING (LOADED CONDITIONS)			TENSION (LBS.)
	0	32	60	0
TEMP. °C	-20	0	15	-20
	4 LB. WIND, ½" ICE	½" ICE	6 LB. WIND	4 LB. WIND, ½" ICE
DEAD END SPAN (FEET)				
50	5.76	4.92	2.88	697
75	11.40	9.60	5.88	795
100	18.12	15.24	9.60	892
125	25.68	21.60	13.80	984
150	33.96	28.44	18.36	1072
175	44.16	37.68	25.92	*1120
200	57.72	50.52	38.52	*1120
225	73.08	65.40	53.40	*1120
250	90.24	82.08	70.44	*1120
275	109.32	100.80	89.28	*1120
300	130.08	121.32	110.04	*1120

\* Note: Design Specification Constraint

#4, 7/1 STRANDING, ACSR, 30 MIL PE COVERING, "HICKORY"  
MAINTENANCE ONLY

	OVERHEAD CONSTRUCTION STANDARD	PAGE NUMBER	ISSUE
		6-219	7/15

© 2022 PPL Corporation. All rights reserved.

Doc. # ST. 06.00.004

Std. Item:	
Item ID:	
CU:	C04ASPE6NE

PHYSICAL PROPERTIES		LOADING PROPERTIES		ELECTRICAL PROPERTIES		
R.B.S.	1770 lbs.	TRANSVERSE	0.4577 Lb/Ft	SUMMER (37.7°C)	MAXIMUM AMPACITY	WINTER (10°C)
C.S.A.	0.0411 sq. in.	VERTICAL	0.613 Lb/Ft			
R. (@ 25°C)	0.4120 Ω / 1000'	TOTAL	1.065 Lb/Ft	135	NORMAL	199
R. (@ 75°C)	0.5220 Ω / 1000'			163	EMERGENCY	216
TEMP. LIMIT	167°F (75°C) / 194°F (90°C)	SWING	68.73°			
CONDUCTOR DIAMETER	0.310"					
COMPLETE DIAMETER	0.370"					
WEIGHT	72 lbs / 1000'					

FINAL SAG TABLE								
LOADING (UNLOADED CONDITIONS)								
TEMP. °F	0	32	60	90	120	158	176	194
TEMP. °C	-18	0	15	32	50	70	80	90
	Unloaded	Unloaded	Unloaded	Unloaded	Unloaded	Unloaded	Unloaded	Unloaded
DEAD END SPAN (FEET)								
50	0.60	0.96	1.56	3.48	4.56	6.36	7.20	7.92
75	1.32	2.04	3.48	6.12	7.68	9.84	11.04	12.12
100	2.40	3.60	5.76	9.00	10.80	13.44	14.76	16.08
125	3.84	5.64	8.76	12.00	14.04	17.04	18.60	20.16
150	7.92	12.48	17.76	20.40	23.16	26.88	28.56	30.36
175	19.32	27.36	30.60	33.84	37.08	41.04	42.84	44.64
200	37.92	43.80	47.04	50.40	53.76	57.72	59.64	61.44
225	58.68	63.00	66.24	69.60	72.84	76.92	78.72	80.52
250	81.00	84.72	87.84	91.08	94.32	98.28	100.08	102.00
275	105.00	108.60	111.72	114.96	118.08	122.04	123.84	125.64
300	131.28	134.76	137.76	141.00	144.12	147.96	149.88	151.56

FINAL SAG TABLE				
LOADING (LOADED CONDITIONS)				TENSION (LBS.)
TEMP. °F	0	32	60	0
TEMP. °C	-20	0	15	-20
	4 LB. WIND, ½" ICE	½" ICE	6 LB. WIND	4 LB. WIND, ½" ICE
DEAD END SPAN (FEET)				
50	6.72	5.76	3.60	591
75	13.08	11.04	7.20	688
100	20.52	17.28	11.28	780
125	28.80	24.24	16.08	866
150	40.68	35.28	26.16	*885
175	55.32	49.32	40.32	*885
200	72.24	65.88	57.12	*885
225	91.44	84.84	76.32	*885
250	112.92	106.08	97.80	*885
275	136.80	129.72	121.44	*885
300	162.84	155.64	147.48	*885

\* Note: Design Specification Constraint

#4, 6/1 STRANDING, ACSR, 30 MIL PE COVERING, "BUTTERNUT" MAINTENANCE ONLY			
ISSUE	PAGE NUMBER	OVERHEAD CONSTRUCTION STANDARD	
7/09	6-220		

# Non-Standard Copper Overhead Distribution Conductors

## *Maintenance Only*

NON-STANDARD COPPER OVERHEAD DISTRIBUTION CONDUCTORS MAINTENANCE ONLY			
	OVERHEAD CONSTRUCTION STANDARD	PAGE NUMBER	ISSUE
		6-300	1/07

PHYSICAL PROPERTIES		LOADING PROPERTIES		ELECTRICAL PROPERTIES		
R.B.S.	9160 lbs.	TRANSVERSE	0.5068 Lb/Ft	SUMMER (37.7°C)	MAXIMUM AMPACITY	WINTER (10°C)
C.S.A.	0.1663 sq. in.	VERTICAL	1.290 Lb/Ft			
R. (@ 25°C)	0.0527 Ω / 1000'	TOTAL	1.686 Lb/Ft	486	NORMAL	679
R. (@ 50°C)	0.0574 Ω / 1000'			545	EMERGENCY	718
TEMP. LIMIT	176°F (80°C) / 194°F (90°C)	SWING	21.76°			
CONDUCTOR DIAMETER	0.522"					
WEIGHT	654 lbs.					

FINAL SAG TABLE								
TEMP. °F	LOADING (UNLOADED CONDITIONS)							
	0	32	60	90	120	158	176	194
TEMP. °C	-18	0	15	32	50	70	80	90
	Unloaded	Unloaded	Unloaded	Unloaded	Unloaded	Unloaded	Unloaded	Unloaded
DEAD END SPAN (FEET)								
50	1.32	2.28	4.20	6.72	8.88	11.16	12.12	12.96
75	3.36	5.64	8.64	11.88	14.76	17.88	19.20	20.40
100	6.96	10.68	14.40	18.24	21.72	25.44	27.12	28.68
125	12.48	17.52	21.84	26.04	29.88	34.32	36.24	38.04
150	20.28	25.92	30.60	35.28	39.48	44.28	46.44	48.60
175	30.12	36.12	41.04	45.84	50.40	55.68	57.96	60.24
200	41.76	47.88	52.92	57.96	62.76	68.40	70.92	73.32
225	54.96	61.32	66.48	71.64	76.56	82.44	85.08	87.72
250	69.96	76.32	81.60	86.88	91.92	98.04	100.80	103.56
275	86.52	92.88	98.16	103.68	108.84	115.20	118.08	120.84
300	104.64	111.12	116.40	121.92	127.32	133.80	136.68	139.56

FINAL SAG TABLE				
TEMP. °F	LOADING (LOADED CONDITIONS)			TENSION (LBS.)
	0	32	60	0
TEMP. °C	-20	0	15	-20
	4 LB. WIND, ½" ICE	½" ICE	6 LB. WIND	4 LB. WIND, ½" ICE
DEAD END SPAN (FEET)				
50	3.12	3.84	4.32	*2000
75	7.08	8.28	8.76	*2000
100	12.60	14.16	14.76	*2000
125	19.80	21.60	22.08	*2000
150	28.44	30.48	30.96	*2000
175	38.76	40.92	41.40	*2000
200	50.64	52.92	53.28	*2000
225	64.08	66.48	66.84	*2000
250	79.08	81.48	81.96	*2000
275	95.76	98.28	98.64	*2000
300	114.00	116.52	116.88	*2000

\* Note: Design Specification Constraint

4/0, 7 STRAND, HARD DRAWN COPPER, BARE MAINTENANCE ONLY			
ISSUE	PAGE NUMBER	OVERHEAD CONSTRUCTION STANDARD	
1/07	6-301		

© 2022 PPL Corporation. All rights reserved.

Doc. # ST. 06.00.005

Std. Item:	W13K
Item ID:	9315933
CU:	C10BSTC

PHYSICAL PROPERTIES		LOADING PROPERTIES		ELECTRICAL PROPERTIES		
R.B.S.	4752 lbs.	TRANSVERSE	0.4566 Lb/Ft	SUMMER (37.7°C)	MAXIMUM AMPACITY	WINTER (10°C)
C.S.A.	0.0829 sq. in.	VERTICAL	0.866 Lb/Ft	313	NORMAL	432
R. (@ 25°C)	0.1051 Ω / 1000'	TOTAL	1.279 Lb/Ft	350	EMERGENCY	457
R. (@ 50°C)	0.1150 Ω / 1000'	SWING	29.44°			
TEMP. LIMIT	176°F (80°C) / 194°F (90°C)					
CONDUCTOR DIAMETER	0.368"					
WEIGHT	326 lbs.					

FINAL SAG TABLE								
TEMP. °F	LOADING (UNLOADED CONDITIONS)							
	0	32	60	90	120	158	176	194
TEMP. °C	-18	0	15	32	50	70	80	90
	Unloaded	Unloaded	Unloaded	Unloaded	Unloaded	Unloaded	Unloaded	Unloaded
DEAD END SPAN (FEET)								
50	1.08	1.56	2.64	4.92	7.32	9.96	10.92	11.88
75	2.28	3.48	5.40	8.52	11.88	15.36	16.92	18.24
100	4.08	6.00	8.76	12.72	16.68	21.12	23.04	24.84
125	6.48	9.12	12.72	17.40	21.96	27.24	29.52	31.68
150	9.24	12.84	17.16	22.44	27.72	33.72	36.36	38.88
175	12.60	17.04	22.08	27.96	33.84	40.56	43.56	46.32
200	16.44	21.72	27.48	33.96	40.20	47.64	51.00	54.12
225	23.04	29.76	36.24	43.20	49.92	57.72	61.20	64.56
250	32.28	40.08	47.04	54.36	61.32	69.48	73.08	76.68
275	43.44	51.96	59.40	66.84	73.92	82.32	86.16	89.76
300	56.40	65.40	72.84	80.52	87.72	96.36	100.20	104.04

FINAL SAG TABLE				
TEMP. °F	LOADING (LOADED CONDITIONS)			TENSION (LBS.)
	0	32	60	0
TEMP. °C	-20	0	15	-20
	4 LB. WIND, ½" ICE	½" ICE	6 LB. WIND	4 LB. WIND, ½" ICE
DEAD END SPAN (FEET)				
50	3.60	3.60	2.88	1314
75	7.56	7.32	5.88	1426
100	12.48	11.88	9.48	1542
125	18.12	17.16	13.68	1658
150	24.36	22.92	18.36	1770
175	31.32	29.28	23.52	1877
200	38.76	36.12	29.04	1980
225	48.60	45.60	37.92	*2000
250	60.00	56.76	48.84	*2000
275	72.60	69.24	61.08	*2000
300	86.40	82.80	74.64	*2000

\* Note: Design Specification Constraint

1/0, 7 STRAND, HARD DRAWN COPPER, BARE MAINTENANCE ONLY			
	OVERHEAD CONSTRUCTION STANDARD	PAGE NUMBER	ISSUE
		6-302	7/15

PHYSICAL PROPERTIES		LOADING PROPERTIES		ELECTRICAL PROPERTIES		
R.B.S.	4752 lbs.	TRANSVERSE	0.4947 Lb/Ft	SUMMER (37.7°C)	MAXIMUM AMPACITY	WINTER (10°C)
C.S.A.	0.0942 sq. in.	VERTICAL	0.978 Lb/Ft			
R. (@ 25°C)	0.1051 Ω / 1000'	TOTAL	1.396 Lb/Ft	278	NORMAL	415
R. (@ 50°C)	0.1150 Ω / 1000'			337	EMERGENCY	452
TEMP. LIMIT	167°F (75°C) / 194°F (90°C)	SWING	33.91°			
CONDUCTOR DIAMETER	0.368"					
COMPLETE DIAMETER	0.488"					
WEIGHT	363 lbs / 1000'					

FINAL SAG TABLE								
TEMP. °F	LOADING (UNLOADED CONDITIONS)							
	0	32	60	90	120	158	176	194
TEMP. °C	-18	0	15	32	50	70	80	90
	Unloaded	Unloaded	Unloaded	Unloaded	Unloaded	Unloaded	Unloaded	Unloaded
DEAD END SPAN (FEET)								
50	1.20	1.80	3.36	5.88	8.16	10.56	11.52	12.48
75	2.52	4.08	6.48	9.84	12.96	16.32	17.76	19.08
100	4.56	6.84	10.20	14.28	18.12	22.44	24.24	25.92
125	7.20	10.44	14.40	19.20	23.64	28.80	30.96	33.12
150	10.32	14.52	19.20	24.60	29.76	35.52	38.16	40.56
175	14.04	19.08	24.48	30.48	36.12	42.72	45.60	48.36
200	21.00	27.48	33.60	39.96	45.96	52.92	55.92	58.92
225	30.36	37.80	44.40	51.00	57.24	64.44	67.68	70.80
250	41.88	49.80	56.64	63.36	69.72	77.28	80.64	83.88
275	55.08	63.36	70.20	77.04	83.64	91.32	94.80	98.28
300	69.96	78.24	85.20	92.16	98.76	106.68	110.28	113.76

FINAL SAG TABLE				
TEMP. °F	LOADING (LOADED CONDITIONS)			TENSION (LBS.)
	0	32	60	0
TEMP. °C	-20	0	15	-20
	4 LB. WIND, ½" ICE	½" ICE	6 LB. WIND	4 LB. WIND, ½" ICE
DEAD END SPAN (FEET)				
50	3.84	4.08	3.72	1349
75	7.92	8.04	7.08	1482
100	12.96	12.84	11.04	1617
125	18.72	18.36	15.60	1748
150	25.20	24.48	20.64	1873
175	32.28	31.08	26.28	1991
200	41.88	40.56	35.40	*2000
225	53.04	51.60	46.20	*2000
250	65.52	63.96	58.44	*2000
275	79.20	77.64	72.00	*2000
300	94.32	92.64	87.00	*2000

\* Note: Design Specification Constraint

1/0, 7 STRAND, HARD DRAWN COPPER, 60 MIL PE COVERING MAINTENANCE ONLY			
ISSUE	PAGE NUMBER	OVERHEAD CONSTRUCTION STANDARD	
1/07	6-303		

© 2022 PPL Corporation. All rights reserved. Doc. # ST. 06.00.005

Std. Item:	W13D
Item ID:	9315669 <sup>y</sup>
CU:	C02CUSTBR

PHYSICAL PROPERTIES		LOADING PROPERTIES		ELECTRICAL PROPERTIES		
R.B.S.	5876 lbs.	TRANSVERSE	0.4553 Lb/Ft	SUMMER (37.7°C)	MAXIMUM AMPACITY	WINTER (10°C)
C.S.A.	0.0680 sq. in.	VERTICAL	0.796 Lb/Ft	249	NORMAL	344
R. (@ 25°C)	0.1653 Ω / 1000'	TOTAL	1.217 Lb/Ft	279	EMERGENCY	363
R. (@ 50°C)	0.1809 Ω / 1000'	SWING	35.45°			
TEMP. LIMIT	176°F (80°C) / 194°F (90°C)					
CONDUCTOR DIAMETER	0.366"					
WEIGHT	257 lbs.					

FINAL SAG TABLE								
TEMP. °F	LOADING (UNLOADED CONDITIONS)							
	0	32	60	90	120	158	176	194
TEMP. °C	-18	0	15	32	50	70	80	90
	Unloaded	Unloaded	Unloaded	Unloaded	Unloaded	Unloaded	Unloaded	Unloaded
DEAD END SPAN (FEET)								
50	0.60	0.84	1.20	1.92	3.60	6.60	7.80	9.00
75	1.44	1.92	2.64	3.96	6.60	10.68	12.36	13.92
100	2.64	3.36	4.56	6.72	10.08	15.00	17.16	19.20
125	4.08	5.28	6.96	9.96	14.04	19.80	22.32	24.72
150	5.88	7.56	9.84	13.56	18.36	24.84	27.72	30.48
175	8.16	10.44	13.56	18.00	23.52	30.60	33.84	36.84
200	12.00	15.48	19.80	25.44	31.68	39.24	42.72	45.96
225	17.16	22.32	27.84	34.44	41.16	49.08	52.68	56.04
250	24.48	31.08	37.68	44.88	51.84	60.12	63.72	67.32
275	33.96	41.76	48.96	56.52	63.60	72.12	75.96	79.56
300	45.60	54.24	61.68	69.36	76.68	85.32	89.16	93.00

FINAL SAG TABLE				
TEMP. °F	LOADING (LOADED CONDITIONS)			TENSION (LBS.)
	0	32	60	0
TEMP. °C	-20	0	15	-20
	4 LB. WIND, ½" ICE	½" ICE	6 LB. WIND	4 LB. WIND, ½" ICE
DEAD END SPAN (FEET)				
50	3.00	2.52	1.44	1548
75	6.36	5.40	3.12	1628
100	10.56	9.12	5.52	1721
125	15.72	13.56	8.28	1819
150	21.36	18.60	11.64	1918
175	27.96	24.36	15.72	*2000
200	36.48	32.28	22.44	*2000
225	46.20	41.52	30.72	*2000
250	57.12	51.96	40.56	*2000
275	69.00	63.60	51.96	*2000
300	82.20	76.44	64.56	*2000

\* Note: Design Specification Constraint

<b>#2, 3 STRAND, TYPE A COPPER – COPPERWELD, BARE MAINTENANCE ONLY</b>			
	OVERHEAD CONSTRUCTION STANDARD	PAGE NUMBER	ISSUE
		<b>6-304</b>	<b>7/15</b>

© 2022 PPL Corporation. All rights reserved.

Doc. # ST. 06.00.005

Std. Item:	W13B
Item ID:	9315684
CU:	C02CHSTBR

PHYSICAL PROPERTIES		LOADING PROPERTIES		ELECTRICAL PROPERTIES		
R.B.S.	3050 lbs.	TRANSVERSE	0.4303 Lb/Ft	SUMMER (37.7°C)	MAXIMUM AMPACITY	WINTER (10°C)
C.S.A.	0.0522 sq. in.	VERTICAL	0.698 Lb/Ft			
R. (@ 25°C)	0.1670 Ω / 1000'	TOTAL	1.1207 Lb/Ft	234	NORMAL	321
R. (@ 50°C)	0.1826 Ω / 1000'			261	EMERGENCY	339
TEMP. LIMIT	176°F (80°C) / 194°F (90°C)	SWING	35.46°			
CONDUCTOR DIAMETER	0.292"					
WEIGHT	205 lbs.					

FINAL SAG TABLE								
TEMP. °F	LOADING (UNLOADED CONDITIONS)							
	0	32	60	90	120	158	176	194
TEMP. °C	-18	0	15	32	50	70	80	90
	Unloaded	Unloaded	Unloaded	Unloaded	Unloaded	Unloaded	Unloaded	Unloaded
DEAD END SPAN (FEET)								
50	0.96	1.56	2.52	4.80	7.20	9.84	10.92	11.88
75	2.28	3.36	5.16	8.40	11.64	15.24	16.68	18.12
100	4.08	5.88	8.52	12.48	16.44	21.00	22.92	24.72
125	6.36	8.88	12.48	17.04	57.72	27.00	29.28	31.56
150	9.12	12.48	16.80	22.08	27.36	33.48	36.12	38.64
175	12.36	16.68	21.60	27.60	33.36	40.20	43.20	46.08
200	16.08	21.36	26.88	33.48	39.72	47.28	50.52	53.76
225	22.44	29.04	35.52	42.48	49.20	57.12	60.60	63.96
250	33.12	41.04	48.00	55.32	62.16	70.20	73.80	77.40
275	46.44	54.96	62.28	69.60	76.56	84.72	88.44	92.04
300	61.92	70.68	78.00	85.32	92.28	100.56	104.40	108.00

FINAL SAG TABLE				
TEMP. °F	LOADING (LOADED CONDITIONS)			TENSION (LBS.)
	0	32	60	0
TEMP. °C	-20	0	15	-20
	4 LB. WIND, ½" ICE	½" ICE	6 LB. WIND	4 LB. WIND, ½" ICE
DEAD END SPAN (FEET)				
50	4.68	4.32	3.00	898
75	9.36	8.52	6.00	1003
100	15.12	13.56	9.60	1108
125	21.72	19.32	13.80	1210
150	28.92	25.68	18.60	1306
175	36.84	32.64	23.76	1398
200	45.24	40.08	29.40	1486
225	55.80	49.92	38.16	*1525
250	68.88	62.52	50.64	*1525
275	83.40	76.68	64.68	*1525
300	99.24	92.28	80.28	*1525

\* Note: Design Specification Constraint

#2, 7 STRAND, HARD DRAWN COPPER, BARE MAINTENANCE ONLY			
ISSUE	PAGE NUMBER	OVERHEAD CONSTRUCTION STANDARD	
7/15	6-305		

© 2022 PPL Corporation. All rights reserved. Doc. # ST. 06.00.005

Std. Item:	W13E
Item ID:	9312556
CU:	C02CHSTPE

PHYSICAL PROPERTIES		LOADING PROPERTIES		ELECTRICAL PROPERTIES		
R.B.S.	3050 lbs.	TRANSVERSE	0.4601 Lb/Ft	SUMMER (37.7°C)	MAXIMUM AMPACITY	WINTER (10°C)
C.S.A.	0.0585 sq. in.	VERTICAL	0.777 Lb/Ft		213	NORMAL
R. (@ 25°C)	0.1670 Ω / 1000'	TOTAL	1.203 Lb/Ft	257	EMERGENCY	342
R. (@ 50°C)	0.1826 Ω / 1000'					
TEMP. LIMIT	167°F (75°C) / 194°F (90°C)	SWING	39.95°			
CONDUCTOR DIAMETER	0.292"					
COMPLETE DIAMETER	0.382"					
WEIGHT	228 lbs / 1000'					

FINAL SAG TABLE								
TEMP. °F	LOADING (UNLOADED CONDITIONS)							
	0	32	60	90	120	158	176	194
TEMP. °C	-18	0	15	32	50	70	80	90
	Unloaded	Unloaded	Unloaded	Unloaded	Unloaded	Unloaded	Unloaded	Unloaded
DEAD END SPAN (FEET)								
50	1.08	1.80	3.12	5.64	7.92	10.44	11.40	12.36
75	2.52	3.84	6.24	9.48	12.72	16.08	17.52	18.84
100	4.44	6.72	9.84	13.92	17.76	22.08	24.00	25.68
125	6.96	10.08	14.04	18.84	23.28	28.44	30.72	32.76
150	10.08	14.16	18.72	24.12	29.28	35.16	37.68	40.20
175	13.68	18.60	24.00	29.88	35.64	42.24	45.12	47.88
200	19.92	26.16	32.16	38.64	44.64	51.72	54.84	57.84
225	30.36	37.92	44.40	51.00	57.24	64.44	67.68	70.80
250	43.68	51.60	58.20	64.92	71.16	78.60	81.96	85.20
275	59.04	67.08	73.68	80.40	86.64	94.20	97.68	100.92
300	76.08	84.00	90.60	97.32	103.68	111.36	114.84	118.20

FINAL SAG TABLE				
TEMP. °F	LOADING (LOADED CONDITIONS)			TENSION (LBS.)
	0	32	60	0
TEMP. °C	-20	0	15	-20
	4 LB. WIND, ½" ICE	½" ICE	6 LB. WIND	4 LB. WIND, ½" ICE
DEAD END SPAN (FEET)				
50	4.92	4.68	3.72	926
75	9.72	9.12	7.08	1046
100	15.48	14.40	11.16	1163
125	22.08	20.40	15.84	1274
150	29.40	27.00	20.88	1380
175	37.44	34.08	26.52	1479
200	47.40	43.56	35.04	*1525
225	60.00	55.80	47.16	*1525
250	74.04	69.60	60.84	*1525
275	89.52	84.96	76.20	*1525
300	106.56	101.88	93.12	*1525

\* Note: Design Specification Constraint

#2, 7 STRAND, SOFT DRAWN COPPER, 45 MIL PE COVERING MAINTENANCE ONLY			
	OVERHEAD CONSTRUCTION STANDARD	PAGE NUMBER	ISSUE
		6-306	7/21

© 2022 PPL Corporation. All rights reserved.

Doc. # ST. 06.00.005

Std. Item:	W11G
Item ID:	9302814 <sup>E</sup>
CU:	C03CHSTRNE

PHYSICAL PROPERTIES		LOADING PROPERTIES		ELECTRICAL PROPERTIES		
R.B.S.	2433 lbs.	TRANSVERSE	0.4197 Lb/Ft	SUMMER (37.7°C)	MAXIMUM AMPACITY	WINTER (10°C)
C.S.A.	0.0416 sq. in.	VERTICAL	0.636 Lb/Ft			
R. (@ 25°C)	0.2106 Ω / 1000'	TOTAL	1.062 Lb/Ft	202	NORMAL	277
R. (@ 50°C)	0.2303 Ω / 1000'			226	EMERGENCY	292
TEMP. LIMIT	176°F (80°C) / 194°F (90°C)	SWING	38.57°			
CONDUCTOR DIAMETER	0.260"					
WEIGHT	163 lbs.					

FINAL SAG TABLE								
TEMP. °F	LOADING (UNLOADED CONDITIONS)							
	0	32	60	90	120	158	176	194
TEMP. °C	-18	0	15	32	50	70	80	90
DEAD END SPAN (FEET)	Unloaded	Unloaded	Unloaded	Unloaded	Unloaded	Unloaded	Unloaded	Unloaded
50	0.96	1.56	2.52	4.80	7.20	9.84	10.80	11.88
75	2.28	3.36	5.16	8.28	11.64	15.24	16.68	18.12
100	3.96	5.76	8.52	12.48	16.44	21.00	22.92	24.72
125	6.24	8.88	12.36	17.04	21.72	27.00	29.28	31.44
150	9.00	12.48	16.80	22.08	27.36	33.36	36.12	38.64
175	12.36	16.80	21.72	27.72	33.48	40.32	43.32	46.08
200	20.76	27.24	33.24	39.60	45.60	52.56	55.68	58.68
225	33.00	40.56	46.92	53.40	59.40	66.48	69.72	72.72
250	48.36	56.04	62.40	68.88	74.88	82.08	85.32	88.44
275	65.76	73.44	79.68	86.04	92.04	99.24	102.48	105.72
300	84.96	92.40	98.52	104.88	110.88	118.08	121.44	124.68

FINAL SAG TABLE				
TEMP. °F	LOADING (LOADED CONDITIONS)			TENSION (LBS.)
	0	32	60	0
TEMP. °C	-20	0	15	-20
DEAD END SPAN (FEET)	4 LB. WIND, ½" ICE	½" ICE	6 LB. WIND	4 LB. WIND, ½" ICE
50	5.28	4.68	3.00	749
75	10.56	9.24	6.12	851
100	16.80	14.64	9.84	950
125	23.88	20.76	14.16	1045
150	31.56	27.48	18.96	1134
175	40.08	34.80	24.36	*1216
200	52.44	46.56	35.76	*1217
225	66.36	60.00	49.32	*1217
250	81.96	75.24	64.68	*1216
275	99.12	92.28	81.72	*1217
300	117.96	110.88	100.56	*1217

\* Note: Design Specification Constraint

#3, 7 STRAND, HARD DRAWN COPPER, BARE MAINTENANCE ONLY			
ISSUE	PAGE NUMBER	OVERHEAD CONSTRUCTION STANDARD	
7/15	6-307		

© 2022 PPL Corporation. All rights reserved.

Doc. # ST. 06.00.005

Std. Item:	W11H
Item ID:	9302709 <sup>E</sup>
CU:	C03CHSTPENE

PHYSICAL PROPERTIES		LOADING PROPERTIES		ELECTRICAL PROPERTIES		
R.B.S.	2433 lbs.	TRANSVERSE	0.4490 Lb/Ft	SUMMER (37.7°C)	MAXIMUM AMPACITY	WINTER (10°C)
C.S.A.	0.0480 sq. in.	VERTICAL	0.704 Lb/Ft	185	NORMAL	272
R. (@ 25°C)	0.2106 Ω / 1000'	TOTAL	1.135 Lb/Ft	223	EMERGENCY	296
R. (@ 50°C)	0.2303 Ω / 1000'					
TEMP. LIMIT	167°F (75°C) / 194°F (90°C)	SWING	45.00°			
CONDUCTOR DIAMETER	0.260"					
COMPLETE DIAMETER	0.350"					
WEIGHT	175 lbs / 1000'					

FINAL SAG TABLE							
TEMP. °F	LOADING (UNLOADED CONDITIONS)						
	0	32	60	90	120	158	176
TEMP. °C	-20	0	15	32	50	70	80
	Unloaded	Unloaded	Unloaded	Unloaded	Unloaded	Unloaded	Unloaded
DEAD END SPAN (FEET)							
50	1.20	1.80	3.00	5.40	7.68	10.20	11.16
75	2.76	3.96	6.12	9.24	12.36	15.84	17.28
100	4.80	6.96	9.84	13.68	17.52	21.84	23.64
125	7.56	10.44	14.16	18.72	23.16	28.20	30.36
150	10.80	14.64	19.08	24.24	29.16	34.92	37.56
175	19.20	24.96	30.24	35.76	40.92	46.92	49.56
200	31.80	38.40	43.92	49.56	54.72	60.84	63.60
225	47.52	54.12	59.64	65.28	70.44	76.68	79.44
250	65.40	71.88	77.28	82.80	88.08	94.32	97.20
275	85.20	91.56	96.84	102.36	107.52	113.88	116.76
300	106.80	113.04	118.32	123.72	128.88	135.24	138.24

FINAL SAG TABLE				
TEMP. °F	LOADING (LOADED CONDITIONS)			TENSION (LBS.)
	0	32	60	0
TEMP. °C	-20	0	15	-20
	4 LB. WIND, ½" ICE	½" ICE	6 LB. WIND	4 LB. WIND, ½" ICE
DEAD END SPAN (FEET)				
50	5.52	5.16	3.96	779
75	10.68	9.84	7.44	896
100	16.92	15.36	11.52	1007
125	24.00	21.60	16.20	1112
150	31.68	28.44	21.36	1210
175	42.84	39.12	31.80	*1217
200	56.04	51.96	44.52	*1216
225	70.92	66.60	59.28	*1217
250	87.60	83.16	75.84	*1217
275	105.96	101.40	94.20	*1217
300	126.24	121.44	114.24	*1217

\* Note: Design Specification Constraint

#3, 7 STRAND, HARD DRAWN COPPER, 45 MIL PE COVERING  
MAINTENANCE ONLY

	OVERHEAD CONSTRUCTION STANDARD	PAGE NUMBER	ISSUE
		6-308	7/15

© 2022 PPL Corporation. All rights reserved. Doc. # ST. 06.00.005

Std. Item:	W11D
Item ID:	9315668 <sup>Y</sup>
CU:	C04CUSTBR

PHYSICAL PROPERTIES		LOADING PROPERTIES		ELECTRICAL PROPERTIES		
R.B.S.	3938 lbs.	TRANSVERSE	0.4302 Lb/Ft	SUMMER (37.7 °C)	MAXIMUM AMPACITY	WINTER (10 °C)
C.S.A.	0.0428 sq. in.	VERTICAL	0.653 Lb/Ft			
R. (@ 25 °C)	0.2629 Ω / 1000'	TOTAL	1.082 Lb/Ft	186	NORMAL	255
R. (@ 50 °C)	0.2875 Ω / 1000'			208	EMERGENCY	270
TEMP. LIMIT	176 °F (80 °C) / 194 °F (90 °C)	SWING	41.83°			
CONDUCTOR DIAMETER	0.290"					
WEIGHT	162 lbs.					

FINAL SAG TABLE								
TEMP. °F	LOADING (UNLOADED CONDITIONS)							
	0	32	60	90	120	158	176	194
TEMP. °C	-18	0	15	32	50	70	80	90
	Unloaded	Unloaded	Unloaded	Unloaded	Unloaded	Unloaded	Unloaded	Unloaded
DEAD END SPAN (FEET)								
50	0.60	0.84	1.08	1.56	3.00	5.88	7.32	8.40
75	1.44	1.80	2.40	3.48	5.76	9.72	11.52	13.20
100	2.52	3.12	4.20	6.00	9.00	13.92	16.08	18.24
125	3.84	4.92	6.36	8.88	12.72	18.48	21.00	23.52
150	5.52	7.08	9.00	12.36	16.80	23.28	26.28	29.04
175	7.56	9.60	12.12	16.08	21.24	28.44	31.68	34.92
200	9.84	12.36	15.60	20.28	26.04	33.84	37.44	40.92
225	12.48	15.60	19.32	24.72	31.08	39.60	43.44	47.28
250	15.48	19.08	23.52	29.52	36.48	45.48	49.68	53.76
275	18.72	23.04	27.96	34.56	42.00	51.72	56.16	60.60
300	22.20	27.24	32.76	39.96	47.88	58.20	63.00	67.56

FINAL SAG TABLE				
TEMP. °F	LOADING (LOADED CONDITIONS)			TENSION (LBS.)
	0	32	60	0
TEMP. °C	-20	0	15	-20
	4 LB. WIND, ½" ICE	½" ICE	6 LB. WIND	4 LB. WIND, ½" ICE
DEAD END SPAN (FEET)				
50	3.84	3.00	1.44	1069
75	7.92	6.36	3.12	1148
100	13.20	10.56	5.40	1235
125	19.20	15.60	8.16	1323
150	25.92	21.12	11.52	1411
175	33.24	27.24	15.24	1497
200	41.04	33.84	19.32	1581
225	49.44	40.92	23.88	1663
250	58.32	48.36	28.68	1742
275	67.56	56.16	33.84	1819
300	77.16	64.32	39.36	1894

\* Note: Design Specification Constraint

<b>#4, 3 STRAND, TYPE A COPPER – COPPERWELD, BARE MAINTENANCE ONLY</b>			
ISSUE	PAGE NUMBER	OVERHEAD CONSTRUCTION STANDARD	
<b>7/15</b>	<b>6-309</b>		

© 2022 PPL Corporation. All rights reserved.

Doc. # ST. 06.00.005

Std. Item:	W11B
Item ID:	9315667 <sup>Y</sup>
CU:	C04CHSOBR

PHYSICAL PROPERTIES		LOADING PROPERTIES		ELECTRICAL PROPERTIES		
R.B.S.	1970 lbs.	TRANSVERSE	0.4010 Lb/Ft	SUMMER (37.7° C)	MAXIMUM AMPACITY	WINTER (10° C)
C.S.A.	0.0328 sq. in.	VERTICAL	0.564 Lb/Ft	171	NORMAL	232
R. (@ 25° C)	0.2602 Ω / 1000'	TOTAL	0.992 Lb/Ft	190	EMERGENCY	245
R. (@ 50° C)	0.2847 Ω / 1000'					
TEMP. LIMIT	176° F (80° C) / 194° F (90° C)	SWING	38.97°			
CONDUCTOR DIAMETER	0.204"					
WEIGHT	126 lbs.					

FINAL SAG TABLE								
TEMP. °F	LOADING (UNLOADED CONDITIONS)							
	0	32	60	90	120	158	176	194
TEMP. °C	-18	0	15	32	50	70	80	90
	Unloaded	Unloaded	Unloaded	Unloaded	Unloaded	Unloaded	Unloaded	Unloaded
DEAD END SPAN (FEET)								
50	0.96	1.44	2.40	4.56	7.08	9.72	10.80	11.76
75	2.16	3.12	4.92	8.04	11.40	15.00	16.56	18.00
100	3.84	5.52	8.16	12.12	16.08	20.76	22.68	24.48
125	6.00	8.52	11.88	16.56	21.24	26.64	29.04	31.20
150	8.64	12.00	16.20	21.60	26.88	33.00	35.76	38.28
175	16.32	22.08	27.72	33.60	39.00	45.36	48.12	50.76
200	29.04	36.00	41.88	47.64	53.16	59.40	62.28	65.04
225	45.24	52.32	57.96	63.72	69.12	75.48	78.36	81.12
250	63.72	70.56	76.08	81.72	87.12	93.48	96.36	99.24
275	84.12	90.60	96.12	101.64	106.92	113.28	116.28	119.16
300	106.32	112.68	117.96	123.36	128.64	135.12	138.00	140.88

FINAL SAG TABLE				
TEMP. °F	LOADING (LOADED CONDITIONS)			TENSION (LBS.)
	0	32	60	0
TEMP. °C	-20	0	15	-20
	4 LB. WIND, ½" ICE	½" ICE	6 LB. WIND	4 LB. WIND, ½" ICE
DEAD END SPAN (FEET)				
50	5.88	5.04	2.88	635
75	11.52	9.72	5.88	733
100	18.24	15.36	9.48	826
125	25.68	21.60	13.68	913
150	33.96	28.68	18.48	*985
175	46.32	40.32	29.76	*985
200	60.48	54.00	43.68	*985
225	76.56	69.72	59.76	*985
250	94.56	87.36	77.76	*985
275	114.48	107.04	97.56	*985
300	136.20	128.76	119.40	*985

\* Note: Design Specification Constraint

<b>#4, SOLID, HARD DRAWN COPPER, BARE MAINTENANCE ONLY</b>			
	OVERHEAD CONSTRUCTION STANDARD	PAGE NUMBER	ISSUE
		<b>6-310</b>	<b>7/15</b>

© 2022 PPL Corporation. All rights reserved.

Doc. # ST. 06.00.005

Std. Item:	W11E
Item ID:	9312557 <sup>Y</sup>
CU:	C04CHSOPE

PHYSICAL PROPERTIES		LOADING PROPERTIES		ELECTRICAL PROPERTIES		
R.B.S.	1970 lbs.	TRANSVERSE	0.4210 Lb/Ft	SUMMER (37.7°C)	MAXIMUM AMPACITY	WINTER (10°C)
C.S.A.	0.0356 sq. in.	VERTICAL	0.611 Lb/Ft			
R. (@ 25°C)	0.2602 Ω / 1000'	TOTAL	1.042 Lb/Ft	159	NORMAL	230
R. (@ 50°C)	0.2847 Ω / 1000'			191	EMERGENCY	250
TEMP. LIMIT	167°F (75°C) / 194°F (90°C)	SWING	44.33°			
CONDUCTOR DIAMETER	0.204"					
COMPLETE DIAMETER	0.264"					
WEIGHT	135 lbs / 1000'					

FINAL SAG TABLE								
TEMP. °F	LOADING (UNLOADED CONDITIONS)							
	0	32	60	90	120	158	176	194
TEMP. °C	-18	0	15	32	50	70	80	90
	Unloaded	Unloaded	Unloaded	Unloaded	Unloaded	Unloaded	Unloaded	Unloaded
DEAD END SPAN (FEET)								
50	1.08	1.56	2.52	4.68	7.20	9.72	10.80	11.76
75	2.28	3.36	5.28	8.28	11.52	15.12	16.68	18.00
100	4.08	5.88	8.64	12.48	16.44	20.88	22.80	24.60
125	6.48	9.00	12.48	17.04	21.72	27.00	29.28	31.44
150	10.20	14.04	18.60	23.88	28.92	34.92	37.44	39.96
175	19.44	25.56	30.96	36.60	41.76	47.76	50.40	52.92
200	33.72	40.44	45.96	51.48	56.52	62.64	65.28	67.92
225	51.00	57.60	62.88	68.28	73.44	79.44	82.20	84.84
250	70.32	76.68	81.84	87.24	92.28	98.28	101.16	103.80
275	91.68	97.80	102.84	108.12	113.16	119.16	122.04	124.68
300	114.84	120.84	125.76	130.92	135.96	142.08	144.84	147.60

FINAL SAG TABLE				
TEMP. °F	LOADING (LOADED CONDITIONS)			TENSION (LBS.)
	0	32	60	0
TEMP. °C	-20	0	15	-20
	4 LB. WIND, ½" ICE	½" ICE	6 LB. WIND	4 LB. WIND, ½" ICE
DEAD END SPAN (FEET)				
50	6.12	5.28	3.24	641
75	11.88	10.20	6.48	741
100	18.72	16.08	10.44	835
125	26.40	22.56	14.88	925
150	35.76	30.84	21.48	*985
175	48.60	43.20	33.72	*985
200	63.48	57.72	48.36	*985
225	80.40	74.28	65.16	*985
250	99.24	92.88	84.00	*985
275	120.24	113.64	104.88	*985
300	143.04	136.32	127.68	*985

\* Note: Design Specification Constraint

#4, SOLID, HARD DRAWN COPPER, 30 MIL PE COVERING MAINTENANCE ONLY			
ISSUE	PAGE NUMBER	OVERHEAD CONSTRUCTION STANDARD	
7/15	6-311		

Std. Item:	W9F
Item ID:	9315670 <sup>Y</sup>
CU:	C6ABCCW

PHYSICAL PROPERTIES		LOADING PROPERTIES		ELECTRICAL PROPERTIES		
R.B.S.	2585 lbs.	TRANSVERSE	0.4103 Lb/Ft	SUMMER (37.7°C)	MAXIMUM AMPACITY	WINTER (10°C)
C.S.A.	0.0269 sq. in.	VERTICAL	0.556 Lb/Ft	140	NORMAL	190
R. (@ 25°C)	0.4186 Ω / 1000'	TOTAL	0.991 Lb/Ft	155	EMERGENCY	201
R. (@ 50°C)	0.4564 Ω / 1000'	SWING	48.43°			
TEMP. LIMIT	176°F (80°C) / 194°F (90°C)					
CONDUCTOR DIAMETER	0.230"					
WEIGHT	102 lbs.					

FINAL SAG TABLE								
TEMP. °F	LOADING (UNLOADED CONDITIONS)							
	0	32	60	90	120	158	176	194
TEMP. °C	-18	0	15	32	50	70	80	90
	Unloaded	Unloaded	Unloaded	Unloaded	Unloaded	Unloaded	Unloaded	Unloaded
DEAD END SPAN (FEET)								
50	0.60	0.72	0.96	1.44	2.52	5.40	6.84	8.04
75	1.32	1.68	2.16	3.24	5.16	9.12	10.92	12.60
100	2.40	3.00	3.84	5.52	8.28	13.08	15.36	17.52
125	3.72	4.68	6.00	8.28	11.88	17.52	20.16	22.68
150	5.28	6.72	8.52	11.52	15.84	22.20	25.20	28.08
175	7.20	9.12	11.40	15.12	20.04	27.24	30.60	33.72
200	9.48	11.76	14.76	19.08	24.72	32.52	36.12	39.72
225	12.00	14.88	18.36	23.40	29.64	38.04	42.00	45.84
250	17.16	21.48	26.64	33.12	40.32	49.32	53.40	57.36
275	26.52	33.24	40.08	47.76	55.32	64.32	68.40	72.36
300	40.44	48.84	56.52	64.44	71.88	80.88	84.96	88.80

FINAL SAG TABLE				
TEMP. °F	LOADING (LOADED CONDITIONS)			TENSION (LBS.)
	0	32	60	0
TEMP. °C	-20	0	15	-20
	4 LB. WIND, ½" ICE	½" ICE	6 LB. WIND	4 LB. WIND, ½" ICE
DEAD END SPAN (FEET)				
50	5.04	3.72	1.44	740
75	10.20	7.80	3.24	818
100	16.56	12.72	5.64	899
125	23.76	18.48	8.52	978
150	31.68	24.84	12.00	1055
175	40.32	31.80	15.84	1130
200	49.44	39.24	20.04	1202
225	59.16	47.16	24.72	1272
250	71.88	58.56	33.84	*1292
275	87.00	72.72	47.28	*1293
300	103.56	88.44	63.24	*1293

\* Note: Design Specification Constraint

<b>#6, 3 STRAND, TYPE A COPPER – COPPERWELD, BARE MAINTENANCE ONLY</b>			
	OVERHEAD CONSTRUCTION STANDARD	PAGE NUMBER	ISSUE
		<b>6-312</b>	<b>7/15</b>

© 2022 PPL Corporation. All rights reserved.

Doc. # ST. 06.00.005

Std. Item:	
Item ID:	
CU:	C06CHSOBR

PHYSICAL PROPERTIES		LOADING PROPERTIES		ELECTRICAL PROPERTIES		
R.B.S.	1280 lbs.	TRANSVERSE	0.3867 Lb/Ft	SUMMER (37.7°C)	MAXIMUM AMPACITY	WINTER (10°C)
C.S.A.	0.0234 sq. in.	VERTICAL	0.491 Lb/Ft			
R. (@ 25°C)	0.4129 Ω / 1000'	TOTAL	0.925 Lb/Ft	128	NORMAL	173
R. (@ 50°C)	0.4527 Ω / 1000'			142	EMERGENCY	182
TEMP. LIMIT	176°F (80°C) / 194°F (90°C)	SWING	45.72°			
CONDUCTOR DIAMETER	0.162"					
WEIGHT	79 lbs.					

FINAL SAG TABLE								
TEMP. °F	LOADING (UNLOADED CONDITIONS)							
	0	32	60	90	120	158	176	194
TEMP. °C	-18	0	15	32	50	70	80	90
	Unloaded	Unloaded	Unloaded	Unloaded	Unloaded	Unloaded	Unloaded	Unloaded
DEAD END SPAN (FEET)								
50	0.96	1.32	2.28	4.32	6.84	9.48	10.56	11.52
75	2.04	3.00	4.68	7.68	11.04	14.76	16.32	17.76
100	3.72	5.28	7.80	11.64	15.72	20.28	22.32	24.12
125	9.24	13.56	18.12	22.68	26.88	31.56	33.72	35.64
150	23.40	29.04	33.48	37.80	41.88	46.44	48.60	50.52
175	42.24	47.40	51.48	55.56	59.52	64.08	66.24	68.28
200	63.48	68.16	72.12	76.08	79.92	84.48	86.52	88.68
225	87.12	91.56	95.40	99.24	102.96	107.52	109.68	111.72
250	113.40	117.72	121.32	125.16	128.88	133.44	135.48	137.64
275	142.20	146.40	150.00	153.72	157.44	162.00	164.16	166.20
300	173.76	177.84	181.44	185.16	188.76	193.32	195.48	197.52

FINAL SAG TABLE				
TEMP. °F	LOADING (LOADED CONDITIONS)			TENSION (LBS.)
	0	32	60	0
TEMP. °C	-20	0	15	-20
	4 LB. WIND, ½" ICE	½" ICE	6 LB. WIND	4 LB. WIND, ½" ICE
DEAD END SPAN (FEET)				
50	7.44	6.00	3.00	463
75	14.28	11.52	6.00	548
100	22.08	17.88	9.72	628
125	33.96	28.68	20.04	*640
150	48.84	43.08	34.92	*640
175	66.48	60.48	52.80	*640
200	86.88	80.64	73.20	*640
225	110.04	103.56	96.48	*640
250	135.84	129.24	122.40	*640
275	164.52	157.80	150.96	*640
300	195.96	189.12	182.40	*640

\* Note: Design Specification Constraint

<b>#6, SOLID, HARD DRAWN COPPER, BARE MAINTENANCE ONLY</b>			
<b>ISSUE</b>	<b>PAGE NUMBER</b>	<b>OVERHEAD CONSTRUCTION STANDARD</b>	
<b>7/15</b>	<b>6-313</b>		

© 2022 PPL Corporation. All rights reserved. Doc. # ST. 06.00.005

Std. Item:	W9E
Item ID:	9312558
CU:	C06CHSOPE

PHYSICAL PROPERTIES		LOADING PROPERTIES		ELECTRICAL PROPERTIES		
R.B.S.	1280 lbs.	TRANSVERSE	0.4070 Lb/Ft	SUMMER (37.7°C)	MAXIMUM AMPACITY	WINTER (10°C)
C.S.A.	0.0234 sq. in.	VERTICAL	0.536 Lb/Ft			
R. (@ 25°C)	0.4129 Ω / 1000'	TOTAL	0.973 Lb/Ft	120	NORMAL	173
R. (@ 50°C)	0.4527 Ω / 1000'			144	EMERGENCY	189
TEMP. LIMIT	167°F (75°C) / 194°F (90°C)	SWING	51.91°			
CONDUCTOR DIAMETER	0.162"					
COMPLETE DIAMETER	0.222"					
WEIGHT	87 lbs / 1000'					

FINAL SAG TABLE								
TEMP. °F	LOADING (UNLOADED CONDITIONS)							
	0	32	60	90	120	158	176	194
TEMP. °C	-18	0	15	32	50	70	80	90
	Unloaded	Unloaded	Unloaded	Unloaded	Unloaded	Unloaded	Unloaded	Unloaded
DEAD END SPAN (FEET)								
50	0.96	1.56	2.76	5.28	7.68	10.20	11.16	12.12
75	2.28	3.48	5.64	9.00	12.24	15.72	17.16	18.60
100	4.80	7.32	10.92	15.00	18.84	23.04	24.84	26.52
125	14.52	19.68	23.88	27.96	31.68	35.88	37.68	39.48
150	31.08	35.88	39.84	43.68	47.28	51.60	53.52	55.32
175	50.40	54.96	58.56	62.28	65.88	70.08	72.00	73.92
200	72.36	76.68	80.16	83.76	87.36	91.56	93.48	95.40
225	97.08	101.16	104.52	108.12	111.60	115.92	117.84	119.76
250	124.44	128.40	131.88	135.36	138.84	143.04	145.08	147.00
275	154.68	158.64	162.00	165.48	168.96	173.16	175.20	177.12
300	187.80	191.76	195.00	198.48	201.96	206.16	208.20	210.12

FINAL SAG TABLE				
TEMP. °F	LOADING (LOADED CONDITIONS)			TENSION (LBS.)
	0	32	60	0
TEMP. °C	-20	0	15	-20
	4 LB. WIND, ½" ICE	½" ICE	6 LB. WIND	4 LB. WIND, ½" ICE
DEAD END SPAN (FEET)				
50	7.56	6.36	3.84	484
75	14.28	11.88	7.44	577
100	22.80	19.44	13.20	*640
125	35.64	31.68	25.68	*640
150	51.36	47.16	41.40	*640
175	69.96	65.52	60.00	*640
200	91.44	86.76	81.48	*640
225	115.80	111.00	105.84	*640
250	143.04	138.24	133.08	*640
275	173.16	168.24	163.20	*640
300	206.16	201.24	196.20	*640

\* Note: Design Specification Constraint

<b>#6, SOLID, HARD DRAWN COPPER, 30 MIL PE COVERING MAINTENANCE ONLY</b>			
	OVERHEAD CONSTRUCTION STANDARD	PAGE NUMBER	ISSUE
		<b>6-314</b>	<b>7/15</b>

Version	Date	Modification	Author(s)	Approval by (Name/Title)
7	4/25	<ul style="list-style-type: none"> <li>Added a table to 6.0</li> <li>Revised Loading Definitions in 6.1</li> </ul>	Zaid Hawatmeh	Chris Bash
6	7/21	<ul style="list-style-type: none"> <li>Added Table 3 to 6-6</li> <li>Updated drawing title on 6-306</li> </ul>		
5	7/18	<ul style="list-style-type: none"> <li>Corrected Description of "Planetree to AAAC in index.</li> <li>Corrected Description in title block to "AAAC. 225' spans" on 6-210.</li> </ul>		
4	7/17	<ul style="list-style-type: none"> <li>Corrected spelling of "Azusa" in Index and in titles on pages 6-125 and 6-126.</li> <li>Corrected reference for conductor data used in calculation – Section 6.2.40.</li> <li>Corrected normal rating temperature on page 6-111.</li> <li>Corrected sag-tension data for standard tree wires on pages 6-105 through 6-110, 6-113 through 6-118 and 6-121 through 6-130.</li> </ul>		
3	7/15	<ul style="list-style-type: none"> <li>Updated item IDs throughout standard.</li> </ul>		
2	7/10	<ul style="list-style-type: none"> <li>Corrected final unloaded sags for 200' and 225' spans on pages 6-203, and 6-205 through 6-217.</li> </ul>		
1	7/09	<ul style="list-style-type: none"> <li>Updated CUs on pages 6-127, 6-128, 6-203, 6-205, 6-208, 6-212, 6-213, 6-214, 6-215, 6-216, 6-217, 6-218, 6-219, 6-220, 6-302, 6-304, 6-305, 6-306, 6-307, 6-308, 6-309, 6-311, 6-313.</li> <li>Updated conductor ampacities on pages 6-107, 6-109, 6-115, 6-117, 6-123, 6-127, 6-129.</li> </ul>		

SUMMARY OF RECENT CHANGES			
ISSUE	PAGE NUMBER	OVERHEAD CONSTRUCTION STANDARD	
4/25	6-NOTES		

PUC 1-12  
**CEMI-4**

Request:

Please explain why the Company appears to be suspending funding of the CEMI-4 program.

Response:

The Company is suspending the CEMI-4 program for two reasons: (i) current system performance, and (ii) prioritization against other work. First, the program always was intended to be a temporary program to drive reliability performance to acceptable levels and then transition to a lesser ad-hoc yearly effort to maintain those levels. Once the temporary program was completed, CEMI-4 analysis was to be incorporated into Engineering Reliability Reviews (ERRs) with investments progressed as necessary. This effort was originally contemplated to be a five-year program.

FY 2024 and FY 2026 ISR Plan CEMI-4 tables are reproduced below, and they show a significant improvement in system numbers over two fiscal years. The black numbers indicate the Company's performance against Electric Edison Institute (EEI) quartile levels. As can be seen, the Company began the program with performance in the third quartile. By FY 2026, the Company's performance was in the second quartile, approaching first quartile. This improvement could have been related to relatively calm recent weather years. Although the work to directly target customers with high multiple interruption counts remains a Company priority, the metric to determine program success can be influenced by weather patterns requiring further review. This is one of the reasons the Company has paused the program.

The second reason for suspending the program funding is for prioritization against other work. Recognizing that the program framework needs to be reviewed and in recognition of budget limitations, the Company's subject matter experts determined this program should be delayed.

PUC 1-12, page 2

**Attachment 4 – Chart 3**  
**RIE CEMI Performance VS EEI Survey 2021**

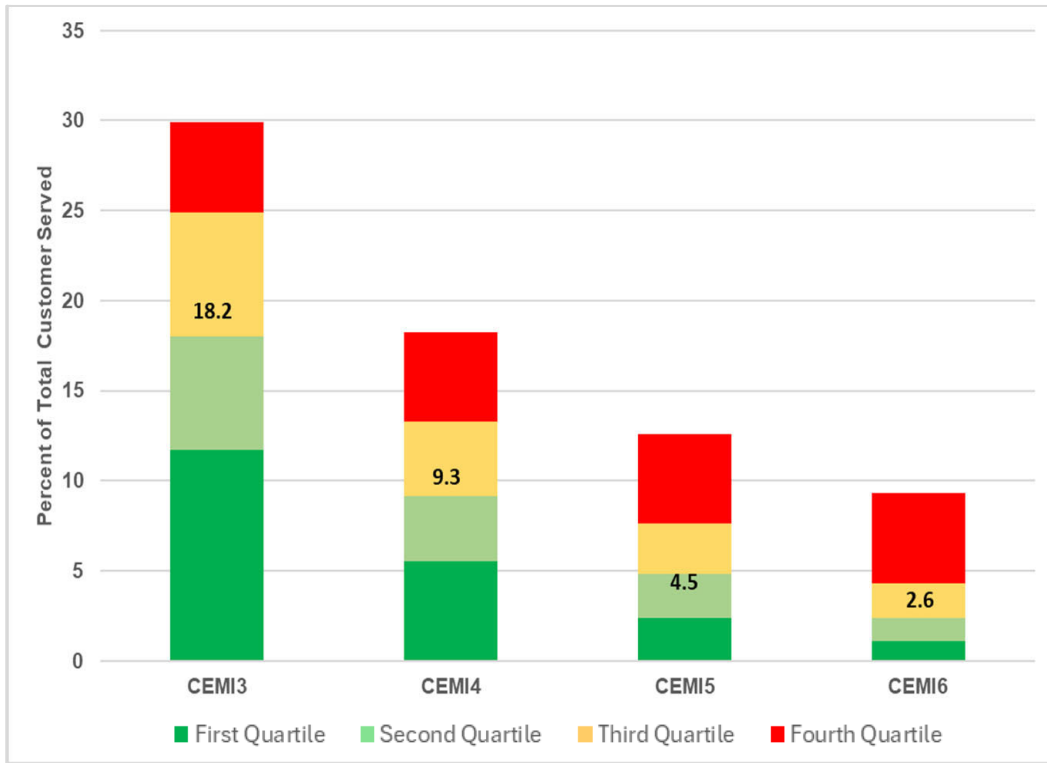

PUC 1-12, page 3

**Attachment 4 – Chart 3**  
**RIE CEMI Performance VS EEI Survey 2023**

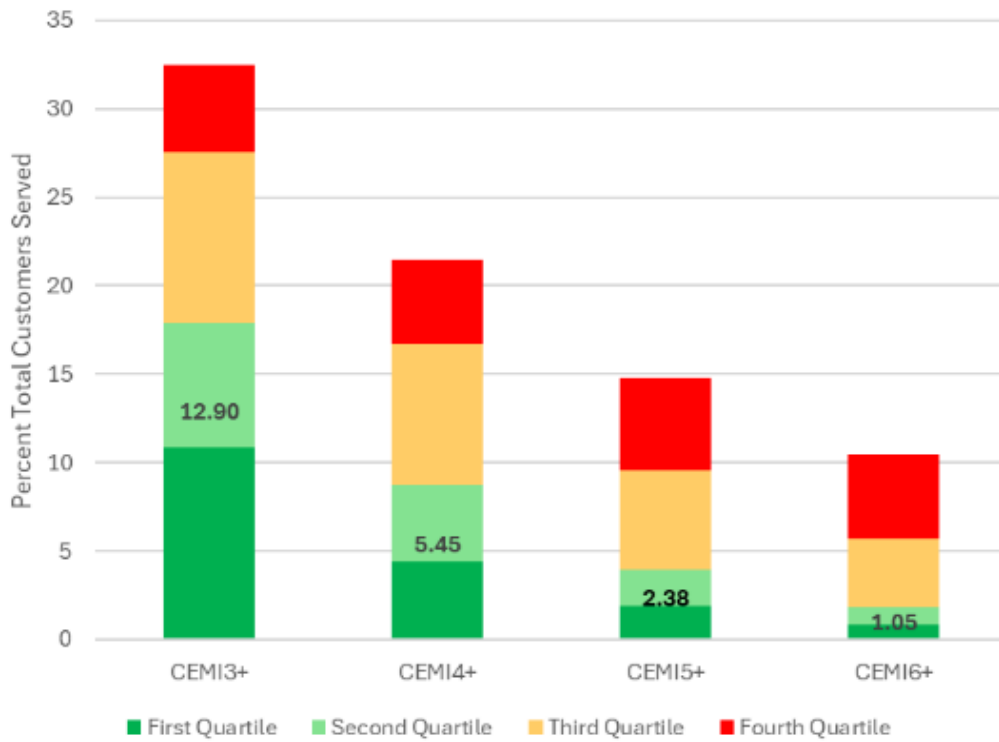

PUC 1-15  
**Electromechanical Relays**

Request:

In its decision in Docket No. 23-48-EL (FY 2025 Electric ISR), the Commission directed Rhode Island Energy to provide a list of each of the electromechanical relays forecasted to be replaced in FY 2025 and indicate whether each is being replaced because it is obsolete (not working or can't find spare parts) or if it is being retired early (although it is still working).

- a. Please provide an update of this information for FY 2026 spending.
- b. Please provide the information for the FY 2027 budget request.

Response:

a. and b.

Please see the following table below for the information requested for parts a. and b. Note that both capital and removal costs are included in the total costs. Also, the term obsolete is used for relays that are no longer supported by their manufacturer or cannot obtain spare parts. All relays are working.

In Re: Proposed FY 2027 Electric Infrastructure, Safety and Reliability Plan  
Responses to the Commission’s First Set of Data Requests  
Issued on January 27, 2026

PUC 1-15, page 2

	(a)	(b)	(c)	(d)	(e)	(f)	(g)
	Station	Feeder	Reason for Replacement	Total Cost FY25	Total Cost FY26	Total Cost FY27	Total Cost FY28
	<b>Complete FY26</b>						
1	Clarke St	65J2	Obsolete	\$200,000	\$200,000	\$0	\$0
2	Lincoln Ave	72F1-F6, 6 Feeders	Obsolete	\$905,000	\$345,000	\$0	\$0
3	Wakefield	17F1-F3 3 feeders	Obsolete	\$300,000	\$415,000	\$0	
	<b>Complete FY27</b>						
4	Old Baptist	46F1	Retired Early	\$9,500	\$38,000	\$145,050	\$0
5	Old Baptist	46F2-F4 3 feeders	Obsolete	\$28,500	\$114,000	\$435,150	\$0
6	Manton Ave	69F1	Obsolete	\$0	\$150,000	\$150,000	\$0
7	Hopkins Hill	63F1	Obsolete	\$0	\$18,333	\$165,000	
8	Hopkins Hill	63F2	Obsolete	\$0	\$18,333	\$165,000	
9	Hopkins Hill	63F3	Obsolete	\$0	\$18,333	\$165,000	
10	Hopkins Hill	63F4	Obsolete	\$0	\$18,333	\$165,000	
11	Hopkins Hill	63F5	Obsolete	\$0	\$18,333	\$165,000	
12	Hopkins Hill	63F6	Retired Early	\$0	\$18,333	\$165,000	
13	Davisville	84T1	Retired Early	\$0	\$19,340	\$174,060	
14	Davisville	84T2	Retired Early	\$0	\$19,340	\$174,060	
15	Davisville	84T3	Obsolete	\$0	\$19,340	\$174,060	
16	Davisville	84T4	Obsolete	\$0	\$19,340	\$174,060	
17	Putnam Pike	38F1	Obsolete	\$0	\$18,673	\$168,060	\$0
18	Putnam Pike	38F2	Obsolete	\$0	\$18,673	\$168,060	\$0
19	Putnam Pike	38F3	Obsolete	\$0	\$18,673	\$168,060	\$0
20	Putnam Pike	38F4	Obsolete	\$0	\$18,673	\$168,060	\$0
21	Putnam Pike	38F5	Retired Early	\$0	\$18,673	\$168,060	\$0
22	Putnam Pike	38F6	Retired Early	\$0	\$18,673	\$168,060	\$0
23	Warren	5F1	Obsolete	\$0	\$0	\$19,340	\$174,060
24	Warren	5F2	Obsolete	\$0	\$0	\$19,340	\$174,060
25	Warren	5F3	Obsolete	\$0	\$0	\$19,340	\$174,060
26	Warren	5F4	Obsolete	\$0	\$0	\$19,340	\$174,060
	<b>Complete FY 28</b>						
27	Wolf Hill	2 Feeders	Obsolete	\$0	\$0	\$68,200	\$613,800
28	Clarkson St	10 Fdrs, 1 tie 13F1-13F10	Obsolete	\$0	\$0	\$201,640	\$1,814,760
29	Staples	5 Feeders 112W41-45	Obsolete	\$0	\$0	\$190,070	\$1,710,630

PUC 1-14  
**CEMI-4**

Request:

The FY 2026 ISR Reconciliation filing will represent the third year of required reporting of CEMI-4 results. The Commission's order in Docket No. 22-53-EL stated, that following investment in selected feeders, "[t]he Company shall then track the feeder CEMI for three years and report the results as part of each ISR filing." Please provide initial results for the FY 2024 feeders covered by the CEMI-4 program.

Response:

In the response to data request Division 1-33 in the fiscal year ("FY") 2026 ISR, Docket No. 24-54-EL, the Company explained that it is not recommended to complete "...a CEMI-4 benefit-cost analysis based on actual costs and performance until a sufficient number of years have passed. A reasonable period is five years; however, the Company is receptive to providing information after at least three years. The earliest this can be done is the middle of 2027 or early 2028." To further explain, at that time, FY 2024 work may not have been completed until March 31, 2024, with the possibility it would be completed by December 31, 2023. It is recommended that complete calendar year reliability data is gathered for analysis. Assuming the FY 2024 work was completed by December 2023, the earliest 3-years of data would be 2024, 2025, and 2026. The 2026 data would be available in early calendar year 2027 with CEMI analysis completed in the middle of 2027.

The work for certain feeders was not completed until well into 2024, and 2024 also was a reliability database conversion year. Thus, the Company can provide an update based on one calendar year of data; however, this evaluation should not be used to determine program success. Data is provided in response to this request for calendar year 2025 only.

The Company identified the following feeders for the FY 2024 CEMI program: 112W44, 127W40, 34F1, 54F1, 63F6, 68F1, and 155F8. Work on the circuits was completed between November 2023 and August 2024, with the latest CEMI values for calendar year 2025.

In Re: Proposed FY 2027 Electric Infrastructure, Safety and Reliability Plan  
Responses to the Commission’s First Set of Data Requests  
Issued on January 27, 2026

PUC 1-14, page 2

	(a)	(b)	(c)	(d)
	<b>CEMI n Circuits</b>	<b>CEMI<sub>n</sub> at the start of program</b>	<b>Construction Year</b>	<b>Calendar Year 2025</b>
1	34F1	8	Jul-24	6
2	54F1	11	Aug-24	11
3	63F6	9	Jan-24	7
4	68F1	13	Jun-24	6
5	112W44	8	Jun-24	7
6	127W40	7	Dec-23	7
7	155F8	10	Nov-23	4

Note: As of the date of this response, 2025 CEMI data is still being finalized. This table was created from the best available data set.

PUC 1-15  
**Electromechanical Relays**

Request:

In its decision in Docket No. 23-48-EL (FY 2025 Electric ISR), the Commission directed Rhode Island Energy to provide a list of each of the electromechanical relays forecasted to be replaced in FY 2025 and indicate whether each is being replaced because it is obsolete (not working or can't find spare parts) or if it is being retired early (although it is still working).

- a. Please provide an update of this information for FY 2026 spending.
- b. Please provide the information for the FY 2027 budget request.

Response:

a. and b.

Please see the following table below for the information requested for parts a. and b. Note that both capital and removal costs are included in the total costs. Also, the term obsolete is used for relays that are no longer supported by their manufacturer or cannot obtain spare parts. All relays are working.

In Re: Proposed FY 2027 Electric Infrastructure, Safety and Reliability Plan  
Responses to the Commission’s First Set of Data Requests  
Issued on January 27, 2026

PUC 1-15, page 2

	(a)	(b)	(c)	(d)	(e)	(f)	(g)
	Station	Feeder	Reason for Replacement	Total Cost FY25	Total Cost FY26	Total Cost FY27	Total Cost FY28
	<b>Complete FY26</b>						
1	Clarke St	65J2	Obsolete	\$200,000	\$200,000	\$0	\$0
2	Lincoln Ave	72F1-F6, 6 Feeders	Obsolete	\$905,000	\$345,000	\$0	\$0
3	Wakefield	17F1-F3 3 feeders	Obsolete	\$300,000	\$415,000	\$0	
	<b>Complete FY27</b>						
4	Old Baptist	46F1	Retired Early	\$9,500	\$38,000	\$145,050	\$0
5	Old Baptist	46F2-F4 3 feeders	Obsolete	\$28,500	\$114,000	\$435,150	\$0
6	Manton Ave	69F1	Obsolete	\$0	\$150,000	\$150,000	\$0
7	Hopkins Hill	63F1	Obsolete	\$0	\$18,333	\$165,000	
8	Hopkins Hill	63F2	Obsolete	\$0	\$18,333	\$165,000	
9	Hopkins Hill	63F3	Obsolete	\$0	\$18,333	\$165,000	
10	Hopkins Hill	63F4	Obsolete	\$0	\$18,333	\$165,000	
11	Hopkins Hill	63F5	Obsolete	\$0	\$18,333	\$165,000	
12	Hopkins Hill	63F6	Retired Early	\$0	\$18,333	\$165,000	
13	Davisville	84T1	Retired Early	\$0	\$19,340	\$174,060	
14	Davisville	84T2	Retired Early	\$0	\$19,340	\$174,060	
15	Davisville	84T3	Obsolete	\$0	\$19,340	\$174,060	
16	Davisville	84T4	Obsolete	\$0	\$19,340	\$174,060	
17	Putnam Pike	38F1	Obsolete	\$0	\$18,673	\$168,060	\$0
18	Putnam Pike	38F2	Obsolete	\$0	\$18,673	\$168,060	\$0
19	Putnam Pike	38F3	Obsolete	\$0	\$18,673	\$168,060	\$0
20	Putnam Pike	38F4	Obsolete	\$0	\$18,673	\$168,060	\$0
21	Putnam Pike	38F5	Retired Early	\$0	\$18,673	\$168,060	\$0
22	Putnam Pike	38F6	Retired Early	\$0	\$18,673	\$168,060	\$0
23	Warren	5F1	Obsolete	\$0	\$0	\$19,340	\$174,060
24	Warren	5F2	Obsolete	\$0	\$0	\$19,340	\$174,060
25	Warren	5F3	Obsolete	\$0	\$0	\$19,340	\$174,060
26	Warren	5F4	Obsolete	\$0	\$0	\$19,340	\$174,060
	<b>Complete FY 28</b>						
27	Wolf Hill	2 Feeders	Obsolete	\$0	\$0	\$68,200	\$613,800
28	Clarkson St	10 Fdrs, 1 tie 13F1-13F10	Obsolete	\$0	\$0	\$201,640	\$1,814,760
29	Staples	5 Feeders 112W41-45	Obsolete	\$0	\$0	\$190,070	\$1,710,630

PUC 1-16  
**Vegetation Management**

Request:

On Bates page 44, Mr. Rooney's testimony states that the On-Cycle Outage Risk reduction [h]as eliminated the need for the Pockets of Poor Performance program for FY 2027. Please clarify whether the Company has recognized an expense reduction in the vegetation management budget or if the spending on pockets of poor performance has been reallocated to the On-Cycle Outage Risk reduction category.

Response:

The Company reallocated the money to the On-Cycle Risk Reduction category. As stated in the Proposed FY 2027 ISR Plan, the additional spending in the On-Cycle Outage Risk Reduction category is a result of the Company identifying additional necessary work on the 34F1 feeder. The additional work was identified by crews as they performed Cycle Pruning work during FY 2026, but the additional work exceeded the initial allocated funding created for the circuit. It is the Company's view that this type of work is vital to improving reliability on "blue sky" days, as well as preventing storm damage. This reallocation can help with this prescribed work and, over the years, the Company has demonstrated this type of work's effectiveness in reducing tree-caused outages.

PUC 1-17  
**Vegetation Management**

Request:

In Mr. Rooney's testimony on Bates page 45, he explains the reason for the decrease in the Vegetation Management budget. On Bates page 155 of the Plan, the following statement is included: "For this fiscal year, the Company increased the FY 2027 budget to address trees on feeders in the FY 2026 work plan" because more trimming was identified on the 34F1 feeder in Foster and Scituate than had been expected and they cannot wait until their next cycle. The 34F1 does not appear in Mr. Rooney's response to DIV-1-47 (vegetation management work plan).

- a. Why doesn't the work plan in the response to DIV-1-47 include the 34F1 feeder?
- b. If the vegetation management work plan should include the 34F1 feeder, please update DIV-1-47.
- c. Did the budget that the Division reviewed during the pre-filing stage include funding for the 34F1 feeder?
- d. Why wasn't the work done on the 34F1 feeder through cycle pruning or on-cycle risk reduction in FY 2026?

Response:

- a. The 34F1 is a circuit that the Company's vendor is currently working as part of the FY 2026 workplan. The additional risk reduction work the Company is proposing on this circuit is a continuation of work already started. The authorization to do this type of work on the dead / hazard trees is with each property owner. Due to the limited scope remaining on the 34F1 for the on-cycle risk reduction work, and because of the uncertainty around obtaining authorization, the Company left the work off the submitted workplan but did include the expected cost in the overall budget. The intention of these additional funds is to make sure this particular circuit is as reliable as can be between now and the next time it is visited.
- b. Due to the small scope of the remaining work, and timing uncertainties around gaining authorization, the Company does not intend to update the workplan. The workplan is intended to illustrate the feeders targeted for cycle pruning, which accounts for the majority of the vegetation management budget.
- c. Yes, the additional funding for the risk remediation work on the 34F1 was included in the budget that the Division reviewed during the pre-filing stage.

PUC 1-17, page 2

- d. The funding the Company identified is needed to specifically address additional on-cycle risk reduction work. This circuit is the largest circuit in Rhode Island (171 Miles). As the work on this circuit progressed, the team found more tree issues than the Company had allocated funding for in the FY 2026 budget. The Company decided not to take funding away from other circuits being worked to fund this work. The cycle pruning work will be completed on the 34F1 in FY 2026 as planned.

In Re: Proposed FY 2027 Electric Infrastructure, Safety and Reliability Plan  
Responses to the Commission’s First Set of Data Requests  
Issued on January 27, 2026

PUC 1-18  
**Vegetation Management**

Request:

Please provide a schedule comparing each category of the FY 2026 and FY 2027 Vegetation Management budgets (Cycle Pruning, On-Cycle Risk Reduction, Off-Cycle Risk Reduction, Sub-Transmission, Traffic Control Measures, Core Activities).

Response:

The table below provides a comparison of FY 2026 and FY 2027 budgets for each of the Vegetation Management budgets in the ISR Plan.

**Vegetation Management FY 2026 and FY 2027**

	(a)	(b)	(c)
<b>Row</b>	<b>RIE Forestry (\$000)</b>	<b>FY 2026 Budget</b>	<b>FY 2027 Budget</b>
1	Cycle Pruning (Base)	\$9,100	\$8,100
2	Risk Reduction - off cycle	\$250	\$250
3	Sub-T (on & off road)	\$550	\$570
4	Police/Flagman Details	\$1,100	\$1,050
5	Pockets of Poor Performance	\$30	\$0
6	TGRs	\$43	\$100
7	Risk Reduction - Extra	\$1,050	\$1,330
8	Core Crews (all other activities)	\$1,700	\$1,500
9	Employee/Other Expenses		
10	<b>Total Vegetation Management O &amp; M Spending</b>	<b>\$13,823</b>	<b>\$12,900</b>

Certificate of Service

I hereby certify that a copy of the cover letter and any materials accompanying this certificate was electronically transmitted to the individuals listed below.

The paper copies of this filing are being hand delivered to the Rhode Island Public Utilities Commission and to the Rhode Island Division of Public Utilities and Carriers.

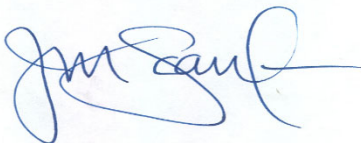

\_\_\_\_\_  
Joanne M. Scanlon

February 12, 2026  
Date

**Docket No. 25-54-EL – RI Energy’s Electric ISR Plan FY 2027  
Service List as of 1/9/2026**

<b>Name/Address</b>	<b>E-mail Distribution</b>	<b>Phone</b>
<b>The Narragansett Electric Company d/b/a Rhode Island Energy</b> Jennifer Brooks Hutchinson, Esq. 280 Melrose St. Providence, RI 02907  Adam S. Ramos, Esq. <b>Hinckley Allen</b> 100 Westminster Street, Suite 1500 Providence, RI 02903-2319	<a href="mailto:JHutchinson@pplweb.com">JHutchinson@pplweb.com</a> ;	401-316-7429
	<a href="mailto:cobrien@pplweb.com">cobrien@pplweb.com</a> ;	
	<a href="mailto:jscanlon@pplweb.com">jscanlon@pplweb.com</a> ;	
	<a href="mailto:aramos@hinckleyallen.com">aramos@hinckleyallen.com</a> ;	
	<a href="mailto:AGiron@hinckleyallen.com">AGiron@hinckleyallen.com</a> ;	
	<a href="mailto:sbriggs@pplweb.com">sbriggs@pplweb.com</a> ;	
	<a href="mailto:KMCampbell@RIEnergy.com">KMCampbell@RIEnergy.com</a> ;	
	<a href="mailto:PLaFond@RIEnergy.com">PLaFond@RIEnergy.com</a> ;	
	<a href="mailto:NKocon@RIEnergy.com">NKocon@RIEnergy.com</a> ;	
	<a href="mailto:JADenson@pplweb.com">JADenson@pplweb.com</a> ;	
	<a href="mailto:CMBird@RIEnergy.com">CMBird@RIEnergy.com</a> ;	
	<a href="mailto:smtoronto@RIEnergy.com">smtoronto@RIEnergy.com</a> ;	
	<a href="mailto:ATLaBarre@RIEnergy.com">ATLaBarre@RIEnergy.com</a> ;	
	<a href="mailto:rconstable@RIEnergy.com">rconstable@RIEnergy.com</a> ;	
	<a href="mailto:krcastro@RIEnergy.com">krcastro@RIEnergy.com</a> ;	
	<a href="mailto:CJRooney@RIEnergy.com">CJRooney@RIEnergy.com</a> ;	
	<a href="mailto:joliveira@pplweb.com">joliveira@pplweb.com</a> ;	
<a href="mailto:TGShields@pplweb.com">TGShields@pplweb.com</a> ;		
<a href="mailto:nhawk@pplweb.com">nhawk@pplweb.com</a> ;		
<a href="mailto:PDCapwell@RIEnergy.com">PDCapwell@RIEnergy.com</a> ;		
<a href="mailto:PJWalnock@pplweb.com">PJWalnock@pplweb.com</a> ;		

	<a href="mailto:CAGill@RIEnergy.com">CAGill@RIEnergy.com</a> ;	
	<a href="mailto:EMcCord@RIEnergy.com">EMcCord@RIEnergy.com</a> ;	
<b>Division of Public Utilities (Division)</b> Gregory Schultz, Esq. Margaret Hogan, Esq.	<a href="mailto:Gregory.Schultz@dpuc.ri.gov">Gregory.Schultz@dpuc.ri.gov</a> ;	
	<a href="mailto:Margaret.I.hogan@dpuc.ri.gov">Margaret.I.hogan@dpuc.ri.gov</a> ;	
	<a href="mailto:Ellen.golde@dpuc.ri.gov">Ellen.golde@dpuc.ri.gov</a> ;	
	<a href="mailto:John.bell@dpuc.ri.gov">John.bell@dpuc.ri.gov</a> ;	
	<a href="mailto:Al.contente@dpuc.ri.gov">Al.contente@dpuc.ri.gov</a> ;	
	<a href="mailto:Robert.Bailey@dpuc.ri.gov">Robert.Bailey@dpuc.ri.gov</a> ;	
	<a href="mailto:Christy.Hetherington@dpuc.ri.gov">Christy.Hetherington@dpuc.ri.gov</a> ;	
	<a href="mailto:leo.wold@dpuc.ri.gov">leo.wold@dpuc.ri.gov</a> ;	
	<a href="mailto:mark.a.simpkins@dpuc.ri.gov">mark.a.simpkins@dpuc.ri.gov</a> ;	
	<a href="mailto:kyle.j.lynch@dpuc.ri.gov">kyle.j.lynch@dpuc.ri.gov</a> ;	
	<a href="mailto:jvanreen@vanreenaccounting.com">jvanreen@vanreenaccounting.com</a> ;	
	<a href="mailto:dschmelzer@vanreenaccounting.com">dschmelzer@vanreenaccounting.com</a> ;	
David Effron Berkshire Consulting 12 Pond Path North Hampton, NH 03862-2243	<a href="mailto:Djeffron@aol.com">Djeffron@aol.com</a> ;	603-964-6526
Gregory L. Booth, PLLC 14460 Falls of Neuse Rd. Suite 149-110 Raleigh, N. C. 27614	<a href="mailto:gboothpe@gmail.com">gboothpe@gmail.com</a> ;	919-441-6440
Linda Kushner L. Kushner Consulting, LLC 514 Daniels St. #254 Raleigh, NC 27605	<a href="mailto:Lkushner33@gmail.com">Lkushner33@gmail.com</a> ;	919-810-1616
<b>Office of Energy Resources</b> Adam Fague, Esq.	<a href="mailto:adam.fague@doa.ri.gov">adam.fague@doa.ri.gov</a> ;	
	<a href="mailto:nancy.russolino@doa.ri.gov">nancy.russolino@doa.ri.gov</a> ;	
	<a href="mailto:Christopher.Kearns@energy.ri.gov">Christopher.Kearns@energy.ri.gov</a> ;	
	<a href="mailto:Shauna.Beland@energy.ri.gov">Shauna.Beland@energy.ri.gov</a> ;	
	<a href="mailto:William.Owen@energy.ri.gov">William.Owen@energy.ri.gov</a> ;	
	<a href="mailto:david.augustyn@energy.ri.gov">david.augustyn@energy.ri.gov</a> ;	
<b>Office of Attorney General</b> Nick Vaz, Esq. 150 South Main St. Providence, RI 02903	<a href="mailto:nvaz@riag.ri.gov">nvaz@riag.ri.gov</a> ;	401-274-4400 x 2297
	<a href="mailto:mgomes@riag.ri.gov">mgomes@riag.ri.gov</a> ;	
<b>Conservation Law Foundation (CLF)</b> James Rhodes, Esq. Conservation Law Foundation 235 Promenade Street Suite 560, Mailbox 28 Providence, RI 02908	<a href="mailto:jrhodes@clf.org">jrhodes@clf.org</a> ;	401-225-3441
<b>File an original &amp; 9 copies w/ PUC:</b>	<a href="mailto:stephanie.delarosa@puc.ri.gov">stephanie.delarosa@puc.ri.gov</a> ;	401-780-2107

Stephanie De La Rosa, Commission Clerk Public Utilities Commission 89 Jefferson Blvd. Warwick, RI 02888	<a href="mailto:Cynthia.WilsonFrias@puc.ri.gov">Cynthia.WilsonFrias@puc.ri.gov</a> ;	
	<a href="mailto:Todd.bianco@puc.ri.gov">Todd.bianco@puc.ri.gov</a> ;	
	<a href="mailto:Alan.nault@puc.ri.gov">Alan.nault@puc.ri.gov</a> ;	
	<a href="mailto:Kristen.L.Masse@puc.ri.gov">Kristen.L.Masse@puc.ri.gov</a> ;	
Matt Sullivan, Green Development LLC	<a href="mailto:ms@green-ri.com">ms@green-ri.com</a> ;	
Emily Koo, Director, Acadia Center	<a href="mailto:EKoo@acadiacenter.org">EKoo@acadiacenter.org</a> ;	